

MATHEMATICS

STANDARD SIX

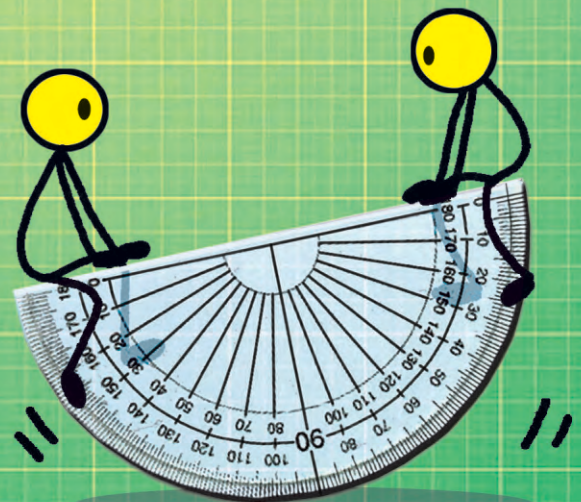

Sanction no. : MSCERT/avivi/sp/2015-16/1673 Date : 06/04/2016

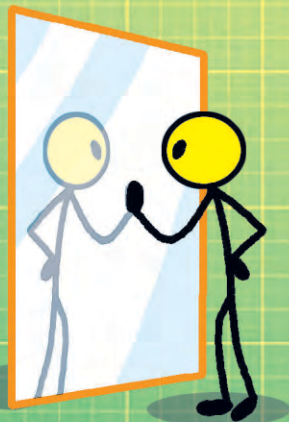
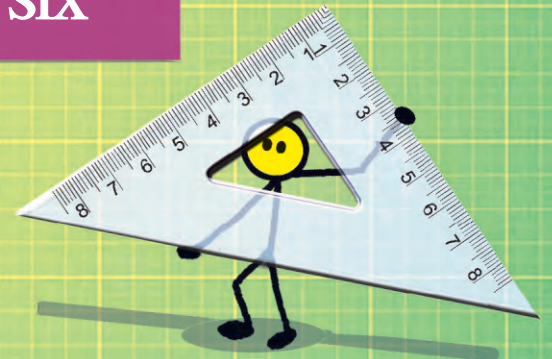
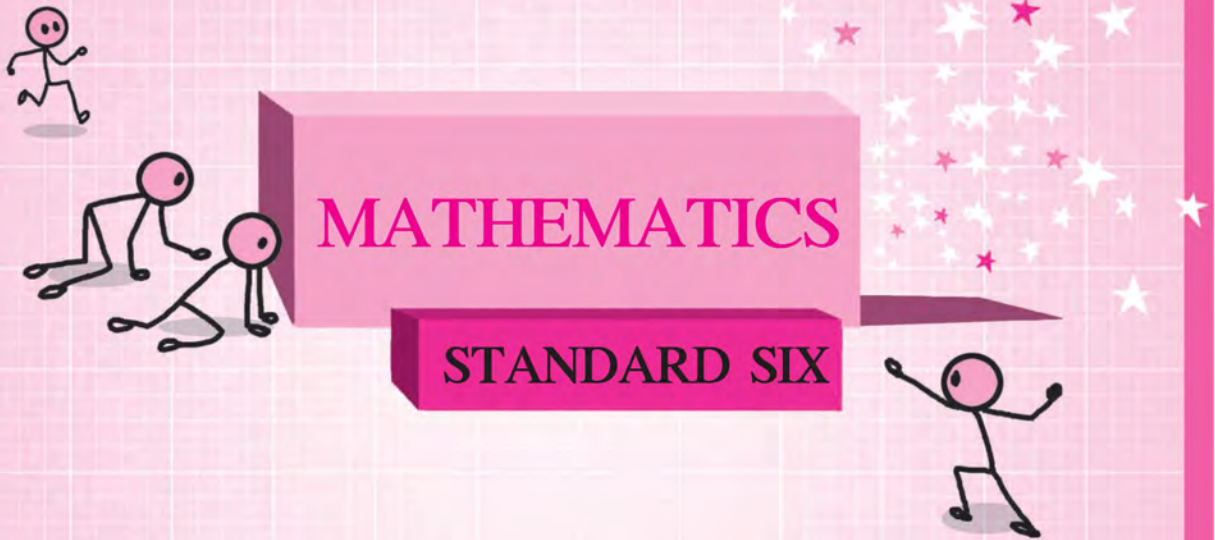

**Maharashtra State Bureau of Textbook Production and
Curriculum Research, Pune.**



The QR Code given alongside and on other pages can be scanned with a smartphone, which leads to link/s (URL) useful for the teaching/learning of this textbook.

First Edition : 2016

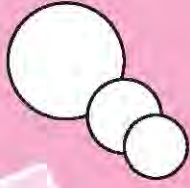

© Maharashtra State Bureau of Textbook Production and Curriculum Research, Pune - 411 004.

The Maharashtra State Bureau of Textbook Production and Curriculum Research reserves all rights relating to the book. No part of this book should be reproduced without the written permission of the Director, Maharashtra State Bureau of Textbook Production and Curriculum Research, Pune.

Mathematics Subject Committee

| | |
|------------------------|--------------------|
| Dr Mangala Naralikar | (Chairman) |
| Dr Jayashri Atre | (Member) |
| Shri. Ramakant Sarode | (Member) |
| Shri. Dadaso Sarade | (Member) |
| Shri Sandeep Panchbhai | (Member) |
| Smt. Lata Tilekar | (Member) |
| Smt. Ujjwala Godbole | (Member-Secretary) |

Publisher

Vivek Uttam Gosavi, Controller
Maharashtra State Textbook Bureau,
Prabhadevi, Mumbai - 400 025.

Cover and Illustrations :

Reshma Barve, Pune

Computer Drawings :

Sandeep Koli, Mumbai

Illustrations :

Dhanashri Mokashi, Reshma Barve

Co-ordination :

Ujjwala Godbole

I/C Special Officer for Mathematics

Translation: Smt. Mrinalini Desai

Scrutiny: Dr Mangala Naralikar

Co-ordination :

Dhanavanti Hardikar

Academic Secretary for Languages

Santosh J. Pawar

Subject Assistant, English

Mathematics Study Group (State)

| | |
|-------------------------|-----------------------------|
| Shri. Umesh Rele | Shri. Sagar Sakude |
| Shri. Chandan Kulkarni | Shri. Shrikant Ratnaparakhi |
| Smt. Anita Jave | Shri. Suryakant Shahane |
| Smt. Bageshri Chavan | Shri. Suresh Date |
| Smt. Puja Jadhav | Smt. Suvarna Deshpande |
| Shri. Annappa Parit | Shri. Prakash Kapse |
| Shri. Kalyan Kadekar | Shri. Saleem Hashmi |
| Shri. Sandesh Sonawane | Smt. Arya Bhide |
| Shri. Sujit Shinde | Shri. Milind Bhakare |
| Dr Hanumant Jagtap | Shri. Dnyaneshwar Mashalkar |
| Shri Shreepad Deshpande | Shri. Lakshman Davankar |
| Shri. Pratap Kashid | Shri. Sudhir Patil |
| Shri. Kashiram Bavisane | Shri. Ganesh Kolte |
| Shri. Pappu Gade | Shri. Rajaram Bandgar |
| Shri. Ansar Shaikh | Smt. Rohini Shirke |
| Shri. Rama Vanyalkar | Shri. Bansi Havale |
| Shri. Pramod Thombare | Shri. Pradeep Godase |
| Shri. Prakash Zende | Shri. Ravindra Khandare |
| | Shri. Rajendra Chaudhari |

Production :

Sachchitanand Aphale

Chief Production Officer

Sanjay Kamble, Production Officer

Prashant Harne, Production Assistant

Typesetting :

Mathematics Section

Textbook Bureau, Pune.

Paper :

70 GSM Cream wove

Printer : SAKAL PAPERS PVT. LTD;
KOLHAPUR

Print Order No. : N/PB/2016-17/55



The Constitution of India

Preamble

WE, THE PEOPLE OF INDIA, having solemnly resolved to constitute India into a SOVEREIGN SOCIALIST SECULAR DEMOCRATIC REPUBLIC and to secure to all its citizens :

JUSTICE, social, economic and political ;

LIBERTY of thought, expression, belief, faith and worship ;

EQUALITY of status and of opportunity ; and to promote among them all

FRATERNITY assuring the dignity of the individual and the unity and integrity of the Nation ;

IN OUR CONSTITUENT ASSEMBLY this twenty-sixth day of November, 1949, do HEREBY ADOPT, ENACT AND GIVE TO OURSELVES THIS CONSTITUTION.

NATIONAL ANTHEM

Jana-gana-mana-adhināyaka jaya hē
Bhārata-bhāgya-vidhātā,

Panjāba-Sindhu-Gujarāta-Marāthā
Drāvida-Utkala-Banga

Vindhya-Himāchala-Yamunā-Gangā
uchchala-jaladhi-taranga

Tava subha nāmē jāgē, tava subha āsisa māgē,
gāhē tava jaya-gāthā,

Jana-gana-mangala-dāyaka jaya hē
Bhārata-bhāgya-vidhātā,

Jaya hē, Jaya hē, Jaya hē,
Jaya jaya jaya, jaya hē.

PLEDGE

India is my country. All Indians
are my brothers and sisters.

I love my country, and I am proud
of its rich and varied heritage. I shall
always strive to be worthy of it.

I shall give my parents, teachers
and all elders respect, and treat
everyone with courtesy.

To my country and my people,
I pledge my devotion. In their
well-being and prosperity alone lies
my happiness.

Preface

The 'Primary Education Curriculum - 2012' was prepared in the State of Maharashtra following the 'Right of Children to Free and Compulsory Education Act, 2009' and the 'National Curriculum Framework 2005'. The Textbook Bureau has launched a new series of Mathematics textbooks based on this syllabus approved by the State Government from the academic year 2013-2014. Mathematics textbooks for Std I to Std V based on this syllabus have already been published. Now, we are happy to place this textbook for Std VI in this series in your hands.

During the teaching-learning process, there should be clarity about the specific competencies that students are expected to learn at the upper-primary level. With that in mind, in this textbook, the mathematical competencies which students are expected to learn have been spelt out in the beginning, and in accordance with those competencies an innovative presentation has been made of the content of the textbook. In order to point out that we come across mathematics in many places in our surroundings and that we use it all the time, some learning experiences have been provided under the title 'Maths my friend ...'. Questions based on experiences of daily life have been asked under the title 'Can you tell?'. Activities suggested under the title 'Try this' will help children to learn certain concepts. Sections such as 'Think about this', 'A Mathematical Riddle', 'Maths is fun!' and some games have been added to help make the subject of mathematics enjoyable.

Our approach while designing this textbook was that the entire teaching-learning process should be child-centred, that emphasis should be on self-learning and that the process of education should become enjoyable and interesting. The concepts included in the areas - Geometry, Number Work, Number Systems, Fractions, Algebra, Commercial Mathematics and Management of Data are explained in simple language. Practice Sets have been provided at the end of every teaching unit. The answers to the problems in the Practice Sets have been given at the end of the textbook. Some 'ICT Tools' have been suggested which will help to make teaching and learning effective.

This book was scrutinized by teachers, educationists and experts at all levels in the field of mathematics and from all parts of the State to make it as flawless and useful as possible. Their comments and suggestions have been duly considered by the Mathematics Subject Committee while finalizing the book.

The Mathematics Subject Committee and The Study Group of the Textbook Bureau and the artists have taken great pains to prepare this book. The Bureau is thankful to all of them.

We hope that this book will receive a warm welcome from students, teachers and parents.



(C. R. Borkar)

Director

Pune

Date : 8 April 2016

Indian Solar Year :

Chaitra 19, 1938

Maharashtra State Bureau of Textbook
Production and Curriculum Research, Pune.

Competencies related to Mathematics : Std VI

It is expected that students will develop the following competencies by the end of Std VI.

| Area – Geometry | |
|---|--|
| <p>1. Basic Concepts in Geometry Students are able to–</p> <ul style="list-style-type: none">• Understand point, line, line segment, ray and parallel lines; read and write their names; identify a plane, collinear and non-collinear points; understand and identify point of concurrence. | <ul style="list-style-type: none">• Identify polygons with more than three sides. |
| <p>2. Angles Students are able to–</p> <ul style="list-style-type: none">• Identify types of angles and classify angles. | <p>5. Reflectional Symmetry Students are able to–</p> <ul style="list-style-type: none">• Recognize reflectional symmetry and the axis of symmetry and to draw the axis.• Complete a symmetrical figure given an axis of symmetry. |
| <p>3. Triangles Students are able to–</p> <ul style="list-style-type: none">• Identify vertices, angles and sides of triangles; read and write their names.• Understand types of triangles based on sides and based on angles.• Understand that the sum of the measures of the three angles of any triangle is 180° and to make use of it.• Understand the property that the sum of the length of any two sides of a triangle is greater than the length of the third side. | <p>6. Geometrical Constructions Students are able to–</p> <ul style="list-style-type: none">• Understand the uses of the geometrical instruments in the compass box.• Draw the perpendicular bisector of a line segment; a perpendicular to a line at a point on the line and from a point outside the line; draw the bisector of an angle; draw an angle equal in measure to a given angle. |
| <p>4. Quadrilaterals and Polygons Students are able to–</p> <ul style="list-style-type: none">• Understand the parts of a quadrilateral, namely, vertices, angles and sides, as also its opposite sides, opposite angles, adjacent angles and adjacent sides.• Understand diagonals of a quadrilateral and the property that the sum of the measures of the four angles of a quadrilateral is 360°. | <p>7. Three-dimensional Shapes Students are able to–</p> <ul style="list-style-type: none">• Understand the difference between prisms and pyramids.• Make different prisms (triangular, quadrangular, etc) with the help of nets.• Identify and tell the numbers of the faces, edges and vertices of a prism, a pyramid, a cylinder, a cone and a sphere. |
| Area – Number Work | |
| | <ul style="list-style-type: none">* Divisibility Students are able to–• Identify a factor, common factors and to find the highest common factor of two or more numbers; to identify a |

| | |
|--|---|
| <p>multiple, common multiples and to find the lowest common multiple.</p> | <p>and to use the operations to solve simple equations.</p> |
| <p>Area – Number Systems</p> | <p>Area – Commercial Mathematics</p> |
| <p>* Integers Students are able to-</p> <ul style="list-style-type: none"> • Understand and recognize natural numbers, whole numbers and integers and to show them on a number line. • Compare integers and understand and carry out addition and subtraction of integers. | <p>1. Ratio and Proportion Students are able to-</p> <ul style="list-style-type: none"> • Understand the meaning of ratio and proportion and their practical uses. • Understand and make use of the unitary method. <p>2. Percentage Students are able to-</p> <ul style="list-style-type: none"> • Understand and make use of ‘percentage’ and its symbol. • To convert given information and percentages from one to the other form. <p>3. Profit and Loss Students are able to-</p> <ul style="list-style-type: none"> • Find and make use of loss percent and profit percent when cost price and selling price are given. <p>4. Banks Students are able to-</p> <ul style="list-style-type: none"> • Understand the need for banks and how to fill the various slips/forms. • Understand principal, interest and rate and to calculate the simple interest for one year. |
| <p>Area – Fractions</p> | |
| <p>1. Operations on Fractions Students are able to-</p> <ul style="list-style-type: none"> • Show fractions on the number line. • Convert mixed numbers and improper fractions from one to the other form. • To carry out and make use of addition, subtraction, multiplication and division of fractions. <p>2. Decimal Fractions Students are able to-</p> <ul style="list-style-type: none"> • Show decimal fractions on the number line. • Convert common fractions and decimal fractions from one to the other form. • Carry out simple multiplications and divisions of decimal fractions. | |
| <p>Area – Algebra</p> | <p>Area – Management of Data</p> |
| <p>* Equations Students are able to-</p> <ul style="list-style-type: none"> • Use a variable to express given information in the form of an equation. • Understand the solution of an equation, the operations used to find the solution | <p>* Bar Graphs Students are able to-</p> <ul style="list-style-type: none"> • Understand the need for bar graphs and to read a bar graph. • Use a graph paper to draw a bar graph of the given information. |

CONTENT

PART ONE

| | |
|-------------------------------------|----------|
| 1. Basic Concepts in Geometry | 1 to 5 |
| 2. Angles | 6 to 11 |
| 3. Integers | 12 to 20 |
| 4. Operations on Fractions | 21 to 28 |
| 5. Decimal Fractions | 29 to 34 |
| 6. Bar Graphs | 35 to 39 |
| 7. Symmetry | 40 to 42 |
| 8. Divisibility | 43 to 45 |
| 9. HCF–LCM | 46 to 50 |

PART TWO

| | |
|--|-----------|
| 10. Equations | 51 to 55 |
| 11. Ratio – Proportion | 56 to 60 |
| 12. Percentage | 61 to 64 |
| 13. Profit – Loss | 65 to 72 |
| 14. Banks and Simple Interest | 73 to 76 |
| 15. Triangles and their Properties | 77 to 80 |
| 16. Quadrilaterals | 81 to 86 |
| 17. Geometrical Constructions | 87 to 92 |
| 18. Three Dimensional Shapes | 93 to 97 |
| Answers | 98 to 104 |

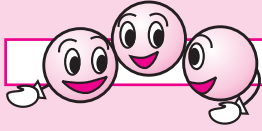

Let's discuss.

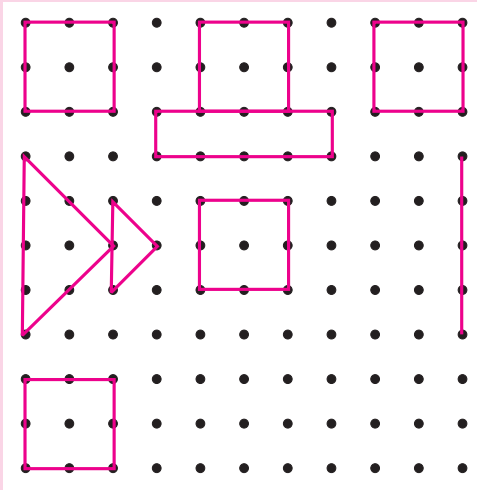

Complete the rangoli. Then, have a class discussion with the help of the following questions :

- (1) What kind of surface do you need for making a rangoli?
- (2) How do you start making a rangoli?
- (3) What did you do in order to complete the rangoli?
- (4) Name the different shapes you see in the rangoli.
- (5) Would it be possible to make a rangoli on a scooter or on an elephant's back?
- (6) When making a rangoli on paper, what do you use to make the dots?



Let's learn.

Points

A point is shown by a tiny dot. We can use a pen or a sharp pencil to make the dot. The dots in the rangoli are the symbols for points.

A point can be given a name. Capital letters of the alphabet are used to name a point. The points P, A and T are shown in the figure alongside.

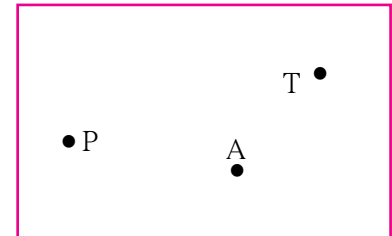

Line Segments and Lines

Take two points A and B on a sheet of paper and join them using a ruler. We get the straight line AB. Can we extend this line further on the side of point B? On the side of point A? How far can we extend it?

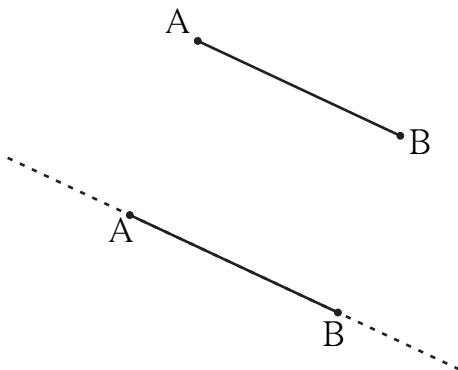

We can extend the line in both directions till the edges of the paper. If the paper is very big, the line can be very long, too.

How long would the line be on a playing field?

Let's imagine that we can extend this line forever without any limits on both sides. To show this extended line on paper, we use arrowheads at both ends of the line. In mathematics, when we say **line**, we mean 'straight line'. The first line that we drew was only from point A to point B. It was a piece or a **segment** of the longer line. A line segment has two points showing its limits. They are called **endpoints**. We write line segment AB as 'seg AB' in short. A and B are its endpoints. A line is named using a small letter or by using any two points on the line. Line l has been shown alongside. Its name can also be written as line PQ or line QP.

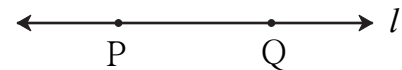
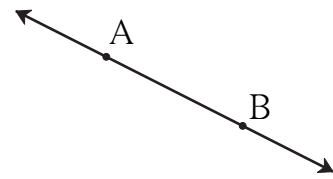

Rays

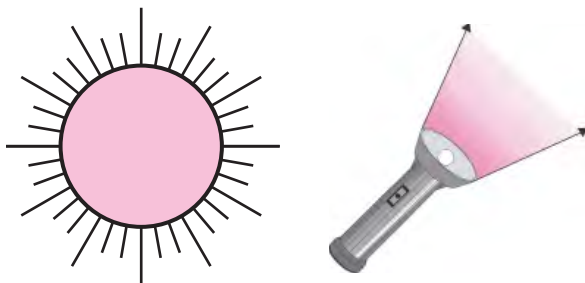

Look at the pictures. What do you see? Rays starting from the sun go forward in all directions. Light rays from the torch also start from a point and go forward continuously in one direction.

A ray is a part of a line. It starts at one point and goes forward continuously in the same direction. The starting point of a ray is called its **origin**. Here, P is the origin. An arrowhead is drawn to show that the ray is infinite in the direction of Q. The figure can be read as **ray PQ**.

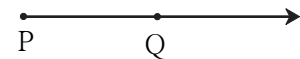

The ray PQ is not read as ray QP.

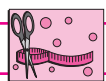

Try this.

Activity 1 : Draw a point on the blackboard. Every student now draws a line that passes through that point.

How many such lines can be drawn?

Activity 2 : Draw a point on a paper and use your ruler to draw lines that pass through it. How many such lines can you draw?

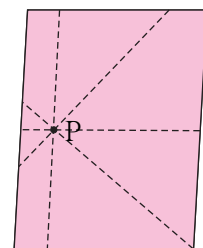

An infinite number of lines can be drawn through one point.

When two or more lines pass through the same point, they are called **concurrent lines** and the common point through which they pass is called their **point of concurrence**.

In the figure alongside, which is the point of concurrence? Name it.

Can you tell?

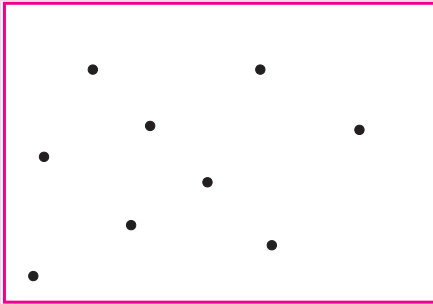

There are 9 points in this figure. Name them.

If you choose any two points, how many lines can pass through the pair?

One and only one line can be drawn through any two distinct points.

Which three or more of these nine points lie on a straight line? **Three or more points which lie on a single straight line are said to be collinear points.** Of these nine points, name any three or more points which do not lie on the same line. **Points which do not lie on the same line are called non-collinear points.**



Let's learn.

Planes

Look at the pictures. What kind of surfaces do you see?

The surfaces in the first two pictures are flat. Each flat surface is a part of an infinite surface. **In mathematics, a flat surface is called a plane.**

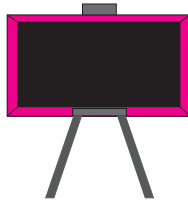
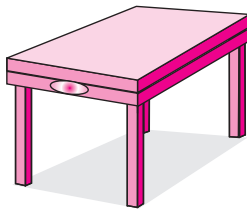

The name of the plane in the picture is 'H'. Even though we draw a suitably small figure of the plane, it actually extends infinitely on all sides. Arrows are drawn to show that the plane extends infinitely in all directions. However, these arrows are often omitted for the sake of convenience.

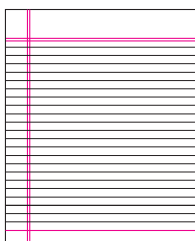
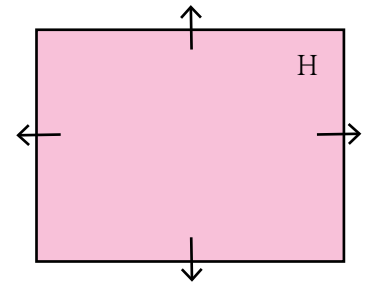

Parallel Lines

Look at this page from a notebook. Is this page a part of a plane? If we extend the lines that run sideways on the page, will they meet each other somewhere?



Now I know -

Lines which lie in the same plane but do not intersect are said to be parallel to each other.

Write the proper term, 'intersecting lines' or 'parallel lines' in each of the empty boxes.

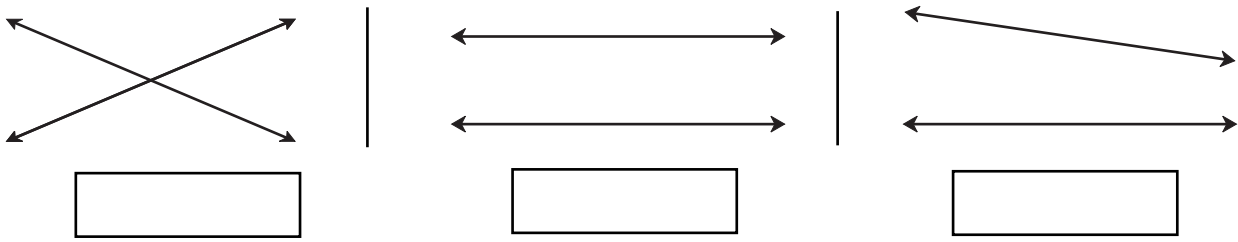

My friend, Maths : On the ground, in the sky.

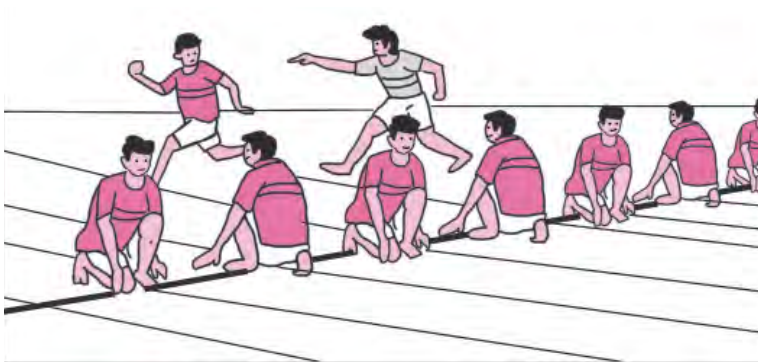

Observe the picture of the game being played. Identify the collinear players, non-collinear players, parallel lines and the plane.

In January, we can see the constellation of Orion in the eastern sky after seven in the evening. Then it moves up slowly in the sky. Can you see the three collinear stars in this constellation? Do you also see a bright star on the same line some distance away?

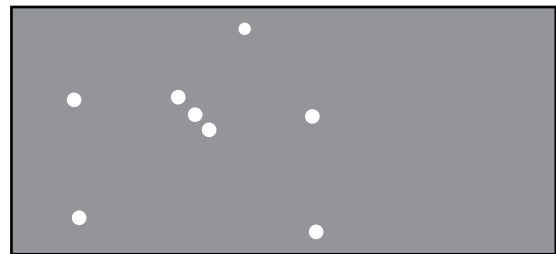

Practice Set 1

1. Look at the figure alongside and name the following:



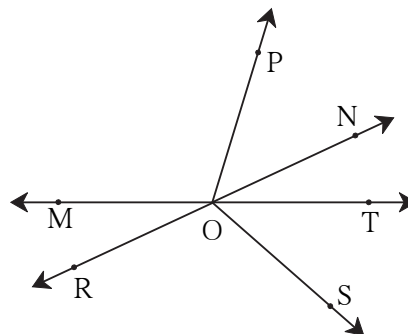

- (1) Collinear points
- (2) Rays
- (3) Line segments
- (4) Lines

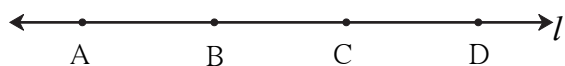

2. Write the different names of the line.



3. Match the following :

- | Group A | Group B |
|---|------------------|
| (i)  | (a) Ray |
| (ii)  | (b) Plane |
| (iii)  | (c) Line |
| (iv)  | (d) Line segment |

4. Observe the figure below. Name the parallel lines, the concurrent lines and the points of concurrence in the figure.

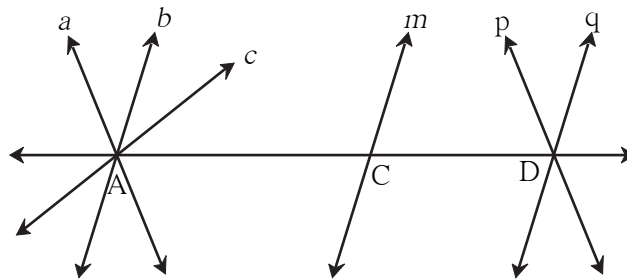

SSS



ICT Tools or Links

Use the tools of the Geogebra software to draw various points, lines and rays.
See for yourself what a never ending line is like.

Maths is fun !

Take a flat piece of thermocol or cardboard, a needle and thread. Tie a big knot or button or bead at one end of the thread. Thread the needle with the other end. Pass the needle up through any convenient point P. Pull the thread up, leaving the knot or the button below. Remove the needle and put it aside. Now hold the free end of the thread and gently pull it straight. Which figure do you see? Now, holding the thread straight, turn it in different directions. See how a countless number of lines can pass through a single point P.

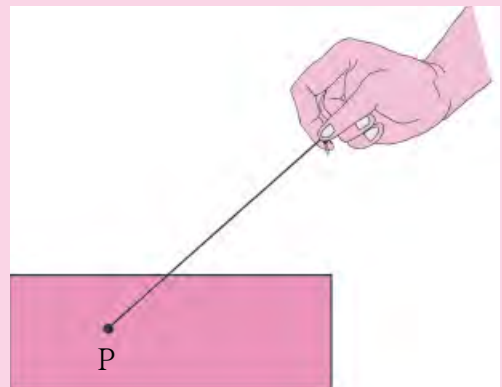



Let's recall.

Angles

Look at the angles shown in the pictures below. Identify the type of angle and write its name below the picture.

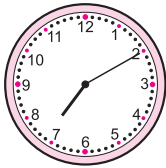

.....



.....



.....

Complete the following table:

| | | | |
|---------------------|--|--|--|
| Angle | | | |
| Name of the angle | | | |
| Vertex of the angle | | | |
| Arms of the angle | | | |

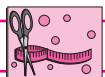

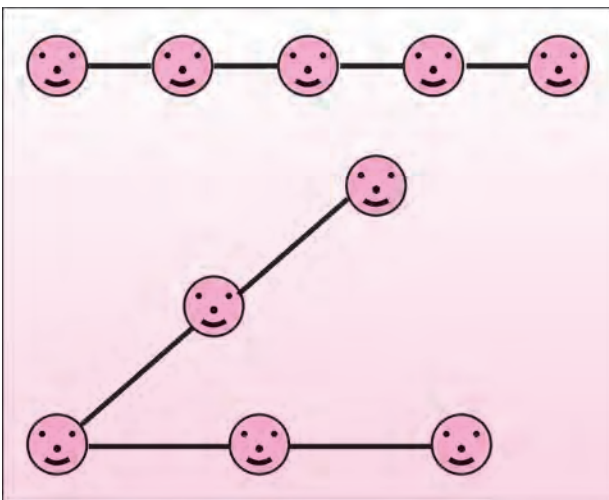

Try this.

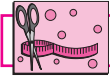

Activity : Ask three or more children to stand in a straight line. Take two long ropes. Let the child in the middle hold one end of each rope. With the help of the ropes, make the children on either side stand along a straight line. Tell them to move so as to form an acute angle, a right angle, an obtuse angle, a straight angle, a reflex angle and a full or complete angle in turn. Keeping the rope stretched will help to ensure that the children form straight lines.

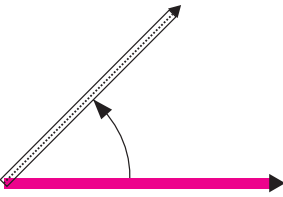
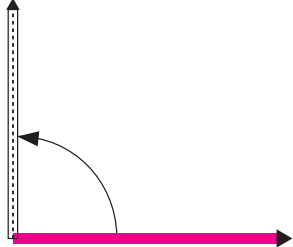
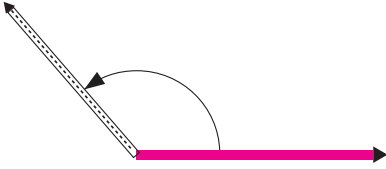

Try this. : Use two sticks of different colours to make the angles from angle (a) to angle (g).

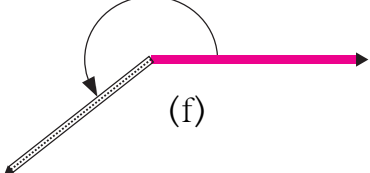
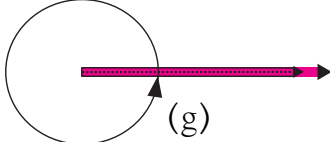
| | |
|--|--|
|  <p>(a)</p> | <p>In figure (a), the two sticks lie one upon the other. There is no change in their position. In this position, the angle between the sticks is called a zero angle. The measure of the zero angle is written as 0°.</p> |
|  <p>(b)</p> | <p>Now, keeping one stick in place, turn the other one around as shown in the figure.</p> <p>The angle formed in figure (b) is angle.</p> <p>An angle greater than 0° but less than 90° is called angle.</p> |
|  <p>(c)</p> | <p>The angle formed in figure (c) is angle.</p> <p>An angle of 90° is called angle.</p> |
|  <p>(d)</p> | <p>The angle formed in figure (d) is angle.</p> <p>An angle greater than 90° but less than 180° is called angle.</p> |
|  <p>(e)</p> | <p>If the stick is turned further in the direction shown in figure (d) we get a position as in figure (e). An angle like this is called a straight angle. A straight angle measures 180°.</p> |
|  <p>(f)</p> | <p>If the stick is turned even further as shown in figure (e), we get an angle like the one in figure (f). This angle is greater than 180°. Such an angle is called a reflex angle. A reflex angle is greater than 180° and less than 360°.</p> |
|  <p>(g)</p> | <p>The stick in figure (f) completes one round and comes back to its original position as in figure (g). It turned through 180° till it made a straight angle and 180° after making the straight angle, thus completing 360° in all. An angle made in this way is called a full or complete angle. The measure of a complete angle is 360°.</p> |



My friend, Maths : At the fair, at home, in the garden.

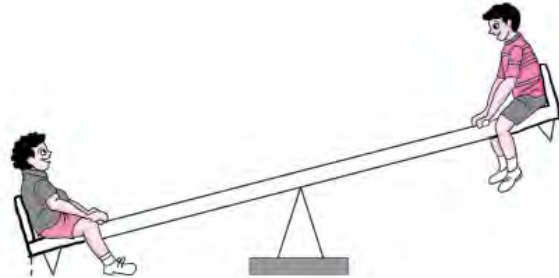
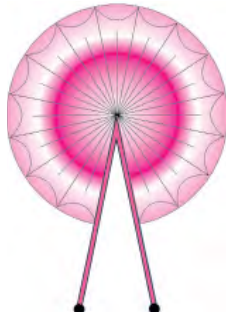
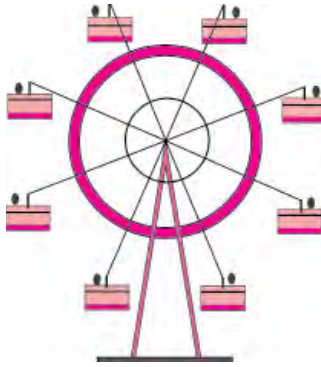

Look at the pictures above and identify the different types of angles.

Practice Set 2

1. Match the following.

Measure of the angle

Type of angle

- | | |
|-----------------|--------------------|
| (1) 180° | (a) Zero angle |
| (2) 240° | (b) Straight angle |
| (3) 360° | (c) Reflex angle |
| (4) 0° | (d) Complete angle |

2. The measures of some angles are given below. Write the type of each angle.

- | | |
|-----------------|-----------------|
| (1) 75° | (2) 0° |
| (3) 215° | (4) 360° |
| (5) 180° | (6) 120° |
| (7) 148° | (8) 90° |

3. Look at the figures below and write the type of each of the angles.

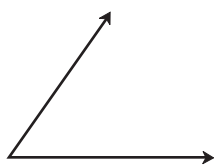

(a)

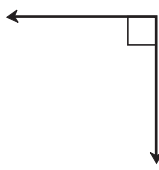

(b)

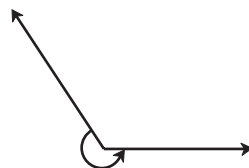

(c)



(d)



(e)



(f)

4. Use a protractor to draw an acute angle, a right angle and an obtuse angle.



Let's recall.

Get to know your compass box.

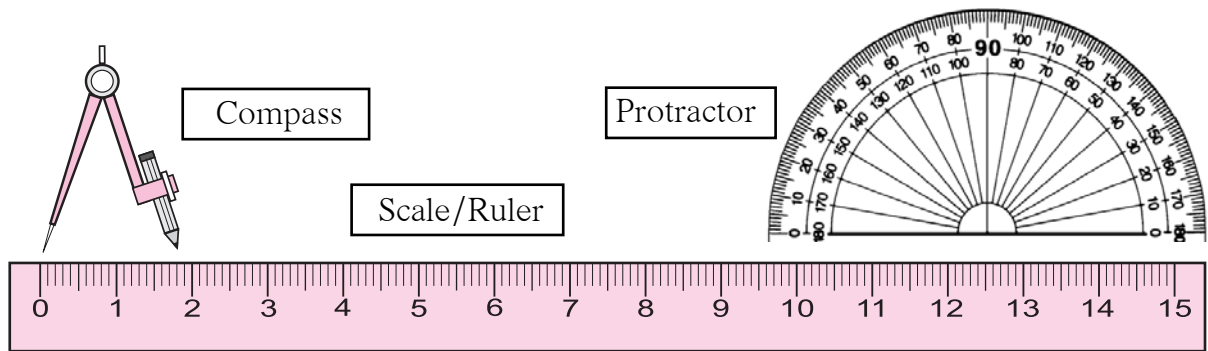

You have learnt what these instruments are used for.



Let's learn.

There are two more types of instruments in the compass box. Let's see how to use them.

Set Squares

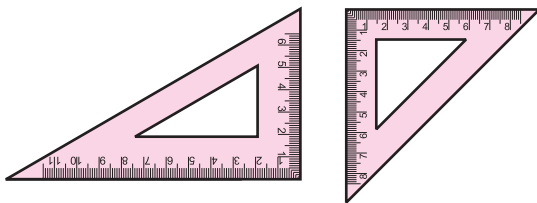

Look at the two **set squares** in the box and observe their angles. Try and see how they can be used to draw angles of 90° , 30° , 60° and 45° .

The Divider



The instrument shown alongside is the **divider**. It is used to measure the distance between two points. To do so, a scale also has to be used along with the divider.

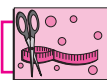

Try this.

An Angle Bisector

Take a sheet of tracing paper. Draw an angle of any measure on it. Fold the paper so that the arms of the angle fall on each other. What does the fold do? Observe that the fold divides the angle into two equal parts. This fold is the **bisector** of the angle.

Take points A and B on the arms of the angle at equal distances from the vertex. Now take points C, P, T on the bisector of the angle. Measure the distance of each of these points from the points A and B.

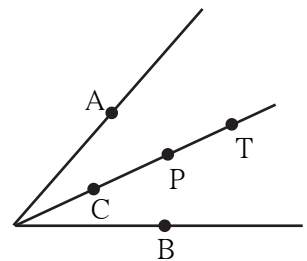

Note that each of the points on the bisector is equidistant from the points A and B.

Let us see how to use geometrical instruments to construct geometrical figures.

(1) To draw an angle bisector using a compass.

Example: Draw any angle ABC. Draw its bisector.

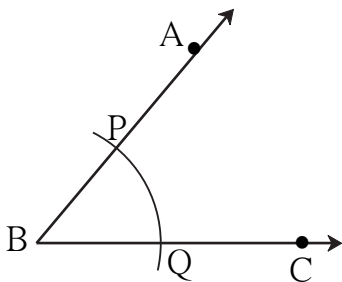

- Draw an angle $\angle ABC$ of any measure.
- Now place the point of a compass on point B and with any convenient distance draw an arc to cut rays BA and BC. Name the points of intersection as P and Q respectively.

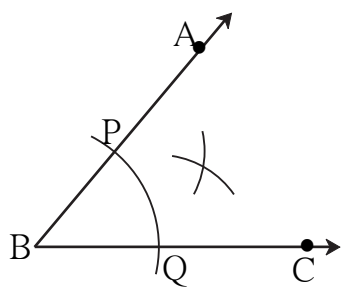

- Now, place the point of the compass at P and taking a convenient distance, draw an arc inside the angle. Using the same distance, draw another arc inside the angle from the point Q, to cut the previous arc.

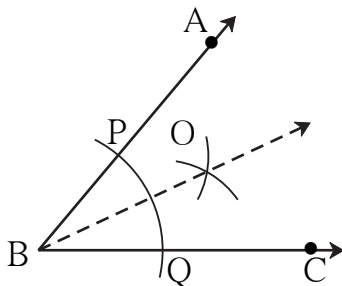

- Name the point of intersection as point O. Now draw ray BO. Ray BO is the bisector of $\angle ABC$. Measure $\angle ABO$ and $\angle CBO$.
- Are they of equal measure?

(2) To construct an angle equal in measure to a given angle, using a compass and ruler.

Example: Look at the given $\angle ABC$ in the figure alongside. Draw $\angle PQR$ equal in measure to $\angle ABC$.

- Draw ray QR.
- Place the compass point at vertex B of $\angle ABC$ and taking a convenient distance, draw an arc to cut the rays BA and BC at points D and E respectively.
- Using the same distance again, place the compass point at point Q of ray QR and draw an arc. Let this arc cut the ray QR at T.
- Now place the point of the compass at point E and open the compass to a distance equal to DE.

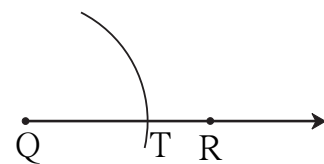
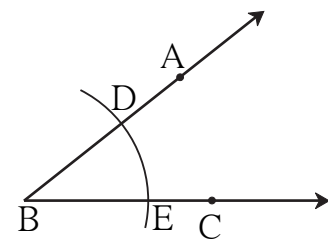

- Now place the compass point on point T.
- Using the distance equal to DE, draw an arc to cut the previous arc at S.
- Draw the ray QS. Take any point P on ray QS.
- Using a protractor verify that the $\angle PQR$ so formed is of the same measure as $\angle ABC$.

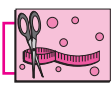
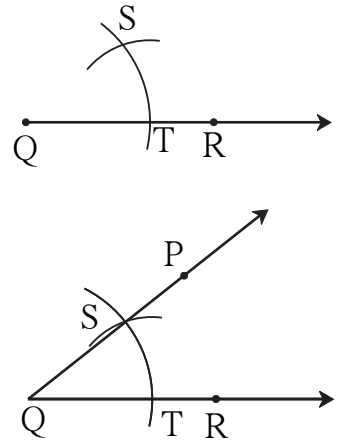

Try this.

(1) Construct an angle bisector to obtain an angle of 30° .

First construct an $\angle ABC$ of measure 60° . Use a compass and ruler to bisect $\angle ABC$. What is the measure of each angle so formed? Verify using a protractor.

(2) Construct an angle bisector to draw an angle of 45° .

Draw two intersecting lines perpendicular to each other. Construct an angle bisector to get an angle of 45° .

Practice Set 3

- * Use the proper geometrical instruments to construct the following angles. Use the compass and the ruler to bisect them.

(1) 50°

(2) 115°

(3) 80°

(4) 90°



ICT Tools or Links

Use the tools in Geogebra to draw angles of different measures. Use the 'move' option and see how the measures of the angle change!





Let's recall.



Count how many boys, flowers and ducks there are in the picture. We have to count objects in order to find out the answer to 'How many?'. Numbers were created because of the need to count things in nature. We write the count of things in the form of numbers.

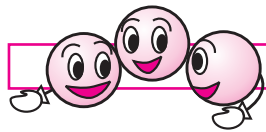

Let's discuss.

Dada : The numbers 1, 2, 3, 4, ... that we have used up to now for counting are called '**counting numbers**'. They are also called **natural numbers**. But is it possible to count the stars in the sky or the grains of sand on the beach? They are innumerable and so are the natural numbers. Look at this list of natural numbers:

Natural numbers : 1, 2, 3, 4, ..., 321, 322, ..., 28573, ...

Samir : We have already learnt to add and subtract these natural numbers. But when we subtract 5 from 5 nothing remains. The zero that we write to show that, is not seen in this list.

Dada : Of course, we cannot do without 'zero'. **The set of all natural numbers together with zero is the set of whole numbers.**

Whole numbers : 0, 1, 2, 3, 4, ..., 367, 368, ..., 237105, ...

Dada : We need to use some other numbers which are not there in this group.

Salma : Which are those?

Dada : Here's an example. In Maharashtra, the temperature falls to 10°C (10 degrees Celsius) or even 8°C in winter, but not down to 0°C . But in Kashmir, it may fall even below 0°C . To show that, we need numbers that are less than zero.

Samir : In January, when the papers said that it was snowing in Kashmir, the temperature in Srinagar was -8°C . How do we read that?

Dada : It is read as 'minus eight degrees Celsius'. When we put a minus sign ($-$) before any number, the number obtained is less than zero. It is called a **negative number**. On a thermometer, there are increasing numbers like 1, 2, 3, ... above 0. These are called **positive numbers**. The numbers below zero are $-1, -2, -3, \dots$.

Samir : Can we show negative numbers on the number line?

Dada : Of course! On the right of zero at distances of 1, 2, 3, units are the numbers 1, 2, 3, On the left of zero at 1, 2, 3, ... unit distances are the numbers $-1, -2, -3, \dots$. They are called **negative numbers**. The numbers 1, 2, 3, on the right are called **positive numbers**. They can be written as 1, 2, 3, ... and also $+1, +2, +3, \dots$.

Salma : On the thermometer, the positive numbers are above zero and the negative numbers are below it. On the number line, they are on the right and left sides of zero respectively. Does it mean that positive and negative numbers are on opposite sides of zero?

Dada : Correct!

Samir : Then should we use positive numbers to show height above sea level and negative numbers for depth below sea level?

Dada : You're right, too! Very good!



Take care!

The ' $+$ ' sign is generally not written before positive numbers. However, it is necessary to write the ' $-$ ' sign of a negative number. Zero does not have any sign.

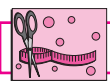

Try this.

Take warm water in one beaker, some crushed ice in another and a mixture of salt and crushed ice in a third beaker. Ask your teacher for help in measuring the temperature of the substance in each of the beakers using a thermometer. Note the temperatures.



Warm water



Crushed ice



Crushed ice and salt



Let's learn.

Integers

Positive numbers, zero and negative numbers together form a group of numbers called the group of integers.



My friend, Maths : At the fair, in the lift.



Look at the picture of the kulfi man. Why do you think he keeps the kulfi moulds in a mixture of salt and ice?



In a lift, the ground floor is numbered 0 (zero) while the floors below the ground level are numbered -1 and -2.



Let's learn.

Showing Integers on the Number Line

The point on a number line which is marked 0 is called the origin. On the left and right of 0, points are marked at equal distances. The numbers shown by points on the right are positive numbers and those shown by points on the left are negative numbers.

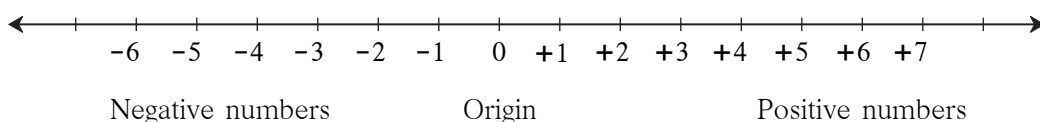

Example : Show the numbers -7 and +8 on the number line.

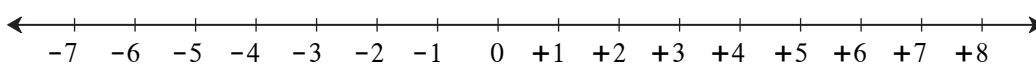

Can you tell?

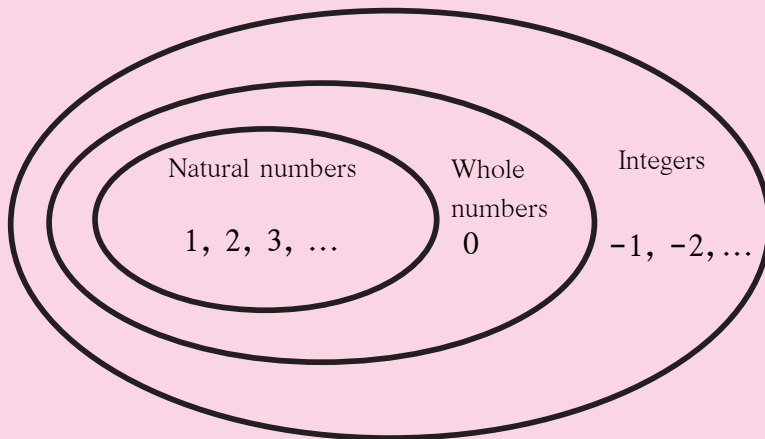

My **class**, that is Std VI, is a part of my **school**. My school is in my **town**. My town is a part of a **taluka**. In the same way, the taluka is a part of a **district**, and the district is a part of Maharashtra **State**.

In the same way, what can you say about these groups of numbers?

Practice Set 4

- Classify the following numbers as positive numbers and negative numbers.

-5, +4, -2, 7, +26, -49, -37, 19, -25, +8, 5, -4, -12, 27

- Given below are the temperatures in some cities. Write them using the proper signs.

| Place | Shimla | Leh | Delhi | Nagpur |
|-------------|---------------|----------------|----------------|----------------|
| Temperature | 7 °C below 0° | 12 °C below 0° | 22 °C above 0° | 31 °C above 0° |

- Write the numbers in the following examples using the proper signs.

- A submarine is at a depth of 512 metres below sea level.
- The height of Mt Everest, the highest peak in the Himalayas, is 8848 metres.
- A kite is flying at a distance of 120 metres from the ground.
- The tunnel is at a depth of 2 metres under the ground.



My friend, Maths : On the playground.

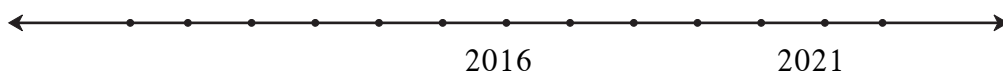

- On the playground, mark a timeline showing the years from 2000 to 2024. With one child standing at the position of the current year, ask the following questions:
 - While playing this game, what is his/her age?
 - Five years ago, which year was it? And what was his/her age then?
 - In which year will he/she go to Std X? How old will he/she be then?

The child should find answers to such questions by walking the right number of units and in the right direction on the timeline.

- Next, the unit on the timeline on the playground should be of 100 years. This will make it possible to count the years from 0 to 2100 on it. Important historical events can then be shown in the proper centuries.

Addition of Integers

On the number line, we shall show the rabbit's hops to the right with positive signs and the ones to the left with negative signs.

Activity:

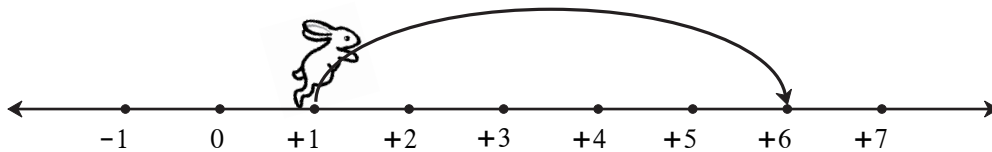

- At first the rabbit was at the number .
- It hopped units to the right.
- It is now at the number .

$$1 + 5 = (+1) + (+5) = +6$$

Activity:

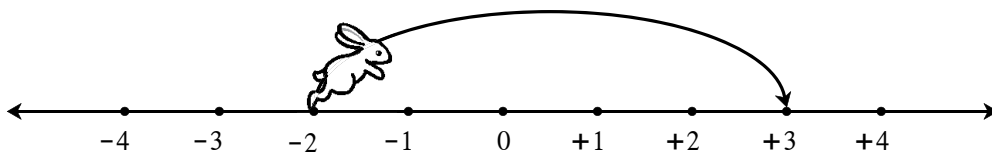

- At first the rabbit was at the number .
- It hopped units to the right.
- It is now at the number .

$$(-2) + (+5) = +3$$



Now I know -

To add a positive number to the given number, we move that many units to the right on the number line from the given number.

Activity:

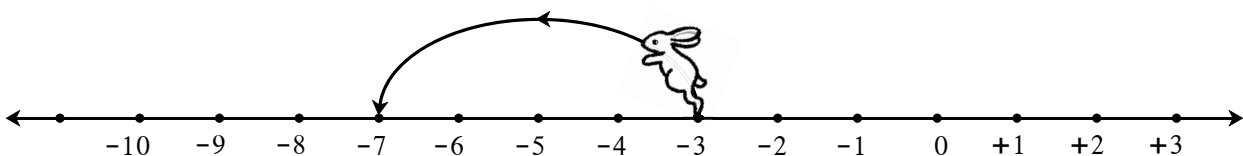

- At first the rabbit was at the number .
- It hopped units to the left.
- It is now at the number .

$$(-3) + (-4) = -7$$



Activity:

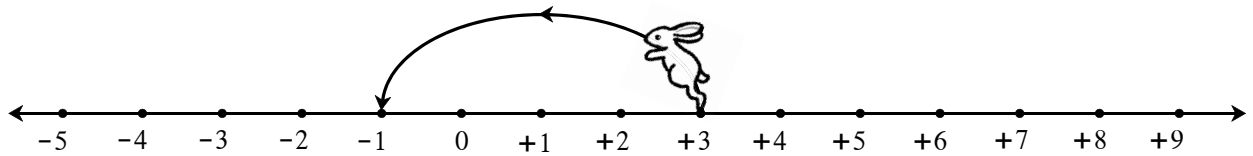

- At first the rabbit was at the number .
- He hopped units to the left.
- It is now at the number .

$$(+3) + (-4) = -1$$



Now I know -

To add a negative number to the given number, we move that many units to the left on the number line from the given number, i.e., we move backward on the number line which means we subtract.

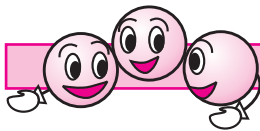

Let's discuss.

Let us understand the addition and subtraction of integers with the help of the amounts of money we get and the amounts we spend.

Dada : We shall show the amount we have or the amount we get as a positive number and the amount we borrow or spend as a negative number.

Anil : I have 5 rupees. That is, I have the number +5. Mother gave me 3 rupees as a gift. That number is +3. Now I have 8 rupees in all.

$$5 + 3 = (+5) + (+3) = +8$$

Dada : You know how to add positive numbers. Now let us add negative numbers. Sunita, if I lend you 5 rupees to buy a pen, how will you show that?

Sunita : I will write the amount I have as negative five or -5.

Dada : If I lend you another 3 rupees, what is your total debt?

Sunita : $(-5) + (-3) = -8$. That means I owe eight rupees.

Dada : You have a debt of 8 rupees. Mother gave you 2 rupees to buy sweets. So you got +2 rupees. Now, if you repay 2 rupees of your debt, how much will you still owe?

Sunita : $(-8) + (+2) = -6$. So, I still owe 6 rupees.

Dada : Anil, you have 8 rupees, or, +8. You spend 3 rupees to buy a pencil. How many rupees do you still have ?

Anil : $(+8) + (-3) = +5$.

Dada : We used the example of earning and spending to understand how to add integers.

For example, $(+5) + (+3) = +8$ and $(-5) + (-3) = -8$

$(-8) + (+2) = -6$ and $(+8) + (-3) = +5$



Now I know -

- When adding integers with the same sign, ignore the signs and add the numbers. Then give the common sign to their sum.
- When adding integers with different signs, ignore the signs and subtract the smaller number from the bigger one. Then, give the sign of the bigger number to the difference obtained.

Practice Set 5

1. Add.

- (1) $8 + 6$
- (2) $9 + (-3)$
- (3) $5 + (-6)$
- (4) $-7 + 2$
- (5) $-8 + 0$
- (6) $-5 + (-2)$

2. Complete the table given below.

| | | | | |
|----|---------------|---|----|----|
| + | 8 | 4 | -3 | -5 |
| -2 | $-2 + 8 = +6$ | | | |
| 6 | | | | |
| 0 | | | | |
| -4 | | | | |



Let's learn.

Opposite Numbers

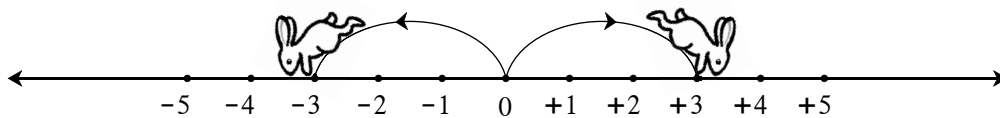

When the rabbit jumps 3 units to its right from 0, it reaches the number +3.

When it jumps 3 units to its left from 0, it reaches the number -3.

Both these distances from zero are equal. Only the directions of the two jumps are opposite to each other. In other words, +3 and -3 are opposite numbers.

Opposite numbers are at the same distance from zero but in opposite directions.

If the rabbit jumps 5 units to the left from 0, where does it reach?

Now, if it jumps 5 units to the right from -5, where does it reach?

$(-5) + (+5) = 0$ and then $(+5) + (-5) = ?$

The sum of two opposite numbers is zero.

Practice Set 6

* Write the opposite number of each of the numbers given below.

| | | | | | | | | |
|------------------------|----|------|------|------|------|------|------|----|
| Number | 47 | + 52 | - 33 | - 84 | - 21 | + 16 | - 26 | 80 |
| Opposite number | | | | | | | | |



Let's learn.

Comparing Integers

You know that if we add 1 to any number on the number line, you get the next number on the right. Note that this is true for negative numbers too.

For example, $-4 + 1 = -3$



$$-4 < -3 < -2 < -1 < 0 < 1 < 2 < 3 < 4 < 5.$$

Now let us compare positive numbers, zero and negative numbers.

For example, $4 > -3$ $4 > 3$ $0 > -1$ $-2 > -3$ $-12 < 7$



Now I know -

On the number line, every number is greater than the number on its immediate left by 1.

Practice Set 7

* Write the proper signs $>$, $<$ or $=$ in the boxes below.

| | | | |
|---------------------|----------------------|---------------------|------------------------|
| (1) $-4 \square 5$ | (2) $8 \square -10$ | (3) $+9 \square +9$ | (4) $-6 \square 0$ |
| (5) $7 \square 4$ | (6) $3 \square 0$ | (7) $-7 \square 7$ | (8) $-12 \square 5$ |
| (9) $-2 \square -8$ | (10) $-1 \square -2$ | (11) $6 \square -3$ | (12) $-14 \square -14$ |



Let's learn.

Subtraction of Integers

Tai : Anil, suppose you have a debt of 8 rupees. If you earn 5 rupees, you first pay off 5 rupees of your debt. Thus your debt is reduced by the amount you earn. The 5 rupees you earn reduce your debt by 5 rupees and are therefore subtracted from your debt. We write it like this : $-(-5) = (+5)$

So your debt is now less than before by 5 rupees, and only 3 rupees remain to be paid back. $(-8) - (-5) = (-8) + 5 = -3$

You already know that $8 + (-5) = 8 - 5 = 3$

With the help of the following examples, learn how to subtract negative numbers.

$$\begin{aligned} (-9) - (-4) \\ = (-9) + 4 \\ = -9 + 4 \\ = -5 \end{aligned}$$

$$\begin{aligned} (-4) - (-9) \\ = (-4) + 9 \\ = -4 + 9 \\ = +5 \end{aligned}$$

$$\begin{aligned} (+9) - (+4) \\ = (+9) + (-4) \\ = +9 - 4 \\ = +5 \end{aligned}$$

$$\begin{aligned} (+9) - (-4) \\ = (+9) + 4 \\ = +9 + 4 \\ = +13 \end{aligned}$$



Now I know -

To subtract a number from another number is to add its opposite number to the other number. For example : $8 - (-6) = 8 + (+6)$

Practice Set 8

- * Subtract the numbers in the top row from the numbers in the first column and write the proper number in each empty box.

| | | | | | | | | |
|----|--------------|---|----|-----------------|---|----|----|----|
| - | 6 | 9 | -4 | -5 | 0 | +7 | -8 | -3 |
| 3 | $3 - 6 = -3$ | | | | | | | |
| 8 | | | | $8 - (-5) = 13$ | | | | |
| -3 | | | | | | | | |
| -2 | | | | | | | | |

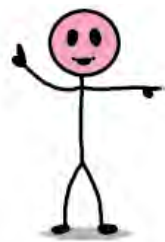

A Game of Integers

The board for playing this game is given on the back cover of the book. Place your counters before the number 1. Throw the dice. Look at the number you get. It is a positive number. Count that many boxes and move your counter forward. If a problem is given in that box, solve it. If the answer is a positive number, move your counter that many boxes further. If it is negative, move back by that same number of boxes.







Suppose we have reached the 18th box. Then the answer to the problem in it is $-4 + 2 = -2$. Now move your counter back by 2 boxes to 16. The one who reaches 100 first, is the winner.



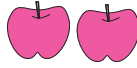
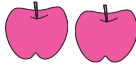

Let's recall.

Let's divide the apples equally between two children.

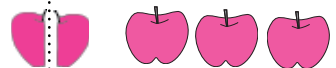
| Apples | Children |  |  | |
|--------|----------|---|--|--------------------------|
| 6 | 2 |  |  | $6 \div 2 = 3$ |
| 4 | 2 |  |  | $4 \div 2 = 2$ |
| 1 | 2 | |  | $1 \div 2 = \frac{1}{2}$ |
| 7 | 2 |  |  | $7 \div 2 = \frac{7}{2}$ |



Let's learn.

Conversion of an Improper Fraction into a Mixed Number

Example : If 7 apples are divided equally between 2 people, how many will each one get?

$$\frac{7}{2} = 7 \div 2$$

| | | |
|---------|---|----------|
| Divisor | $\begin{array}{r} 3 \text{ Quotient} \\ 2 \overline{)7} \\ \underline{-6} \\ 1 \text{ Remainder} \end{array}$ | Dividend |
|---------|---|----------|

$$\frac{7}{2} = 3\frac{1}{2}$$

Each will get 3 full apples and $\frac{1}{2}$ apple.



Take care!

While dividing, we take care to see that the remainder is smaller than the divisor. As a result, in the mixed number, the numerator of the fractional part is smaller than its denominator.



Let's learn.

Conversion of a Mixed Number into an Improper Fraction

Example : $3\frac{2}{5}$ is a mixed number. Convert this into an improper fraction.

$$3\frac{2}{5} = 3 + \frac{2}{5} = \frac{3}{1} + \frac{2}{5} = \frac{3 \times 5}{1 \times 5} + \frac{2}{5} = \frac{3 \times 5 + 2}{5} = \frac{15 + 2}{5} = \frac{17}{5}$$

Practice Set 9

1. Convert into improper fractions.

(i) $7\frac{2}{5}$ (ii) $5\frac{1}{6}$ (iii) $4\frac{3}{4}$ (iv) $2\frac{5}{9}$ (v) $1\frac{5}{7}$

2. Convert into mixed numbers.

(i) $\frac{30}{7}$ (ii) $\frac{7}{4}$ (iii) $\frac{15}{12}$ (iv) $\frac{11}{8}$ (v) $\frac{21}{4}$ (vi) $\frac{20}{7}$

3. Write the following examples using fractions.

(i) If 9 kg rice is shared amongst 5 people, how many kilograms of rice does each person get?

(ii) To make 5 shirts of the same size, 11 metres of cloth is needed. How much cloth is needed for one shirt?



Let's learn.

Addition and Subtraction of Mixed Numbers

Example 1. Add. $5\frac{1}{2} + 2\frac{3}{4}$

Method I

$$\begin{aligned} 5\frac{1}{2} + 2\frac{3}{4} &= 5 + 2 + \frac{1}{2} + \frac{3}{4} \\ &= 7 + \frac{1 \times 2}{2 \times 2} + \frac{3}{4} \\ &= 7 + \frac{2}{4} + \frac{3}{4} \\ &= 7 + \frac{2+3}{4} = 7 + \frac{5}{4} \\ &= 7 + 1 + \frac{1}{4} = 8\frac{1}{4} \end{aligned}$$

Method II

$$\begin{aligned} 5\frac{1}{2} + 2\frac{3}{4} &= \frac{5 \times 2 + 1}{2} + \frac{2 \times 4 + 3}{4} \\ &= \frac{11}{2} + \frac{11}{4} \\ &= \frac{11 \times 2}{2 \times 2} + \frac{11}{4} \\ &= \frac{22}{4} + \frac{11}{4} = \frac{33}{4} \\ &= 8\frac{1}{4} \end{aligned}$$

Example 2. Subtract. $3\frac{2}{5} - 2\frac{1}{7}$

Method I

$$\begin{aligned}3\frac{2}{5} - 2\frac{1}{7} &= (3-2) + \left(\frac{2}{5} - \frac{1}{7}\right) \\ &= 1 + \frac{2 \times 7}{5 \times 7} - \frac{1 \times 5}{7 \times 5} \\ &= 1 + \frac{14}{35} - \frac{5}{35} \\ &= 1 + \frac{9}{35} = 1\frac{9}{35}\end{aligned}$$

Method II

$$\begin{aligned}3\frac{2}{5} - 2\frac{1}{7} &= \frac{17}{5} - \frac{15}{7} \\ &= \frac{17 \times 7}{5 \times 7} - \frac{15 \times 5}{7 \times 5} \\ &= \frac{119}{35} - \frac{75}{35} = \frac{119-75}{35} \\ &= \frac{44}{35} = 1\frac{9}{35}\end{aligned}$$



Think about it.

How to do this subtraction : $4\frac{1}{4} - 2\frac{1}{2}$? Is it the same as $[4 - 2 + \frac{1}{4} - \frac{1}{2}]$?

Practice Set 10

1. Add.

(i) $6\frac{1}{3} + 2\frac{1}{3}$

(ii) $1\frac{1}{4} + 3\frac{1}{2}$

(iii) $5\frac{1}{5} + 2\frac{1}{7}$

(iv) $3\frac{1}{5} + 2\frac{1}{3}$

2. Subtract.

(i) $3\frac{1}{3} - 1\frac{1}{4}$

(ii) $5\frac{1}{2} - 3\frac{1}{3}$

(iii) $7\frac{1}{8} - 6\frac{1}{10}$

(iv) $7\frac{1}{2} - 3\frac{1}{5}$

3. Solve.

(1) Suyash bought $2\frac{1}{2}$ kg of sugar and Ashish bought $3\frac{1}{2}$ kg. How much sugar did they buy altogether? If sugar costs 32 rupees per kg, how much did they spend on the sugar they bought?

(2) Aradhana grows potatoes in $\frac{2}{5}$ part of her garden, greens in $\frac{1}{3}$ part and brinjals in the remaining part. On how much of her plot did she plant brinjals?

(3)* Sandeep filled water in $\frac{4}{7}$ of an empty tank. After that, Ramakant filled $\frac{1}{4}$ part more of the same tank. Then Umesh used $\frac{3}{14}$ part of the tank to water the garden. If the tank has a maximum capacity of 560 litres, how many litres of water will be left in the tank?



Let's learn.

Showing Fractions on the Number Line

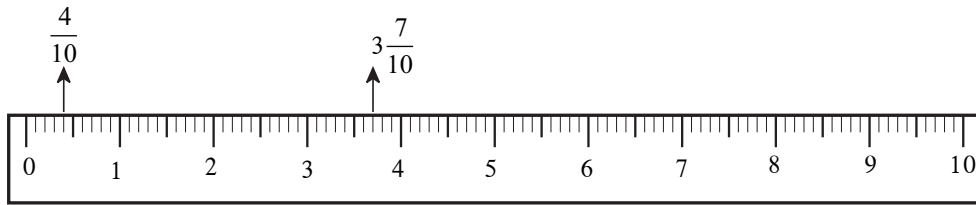

It is easy to mark the fractions $\frac{4}{10}$ and $3\frac{7}{10}$ on the number line because on the scale, every centimetre is divided into 10 equal parts. In the first unit, the fourth mark from zero shows the fraction $\frac{4}{10}$. The 7th mark of the 10 equal parts after 3, between the numbers 3 and 4, shows the fraction $3\frac{7}{10}$.

Example : Let us show the fractions $\frac{2}{3}$, $\frac{4}{3}$, $\frac{7}{3}$ on the number line.

On the number line below, every unit is divided into 3 equal parts.

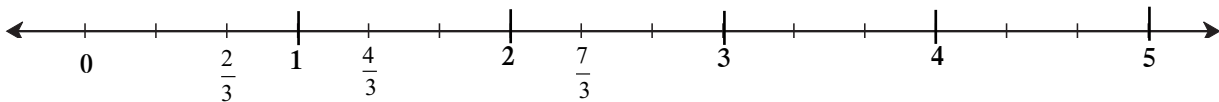

Now I know -

If a fraction has to be shown on a number line, every unit on the number line must be divided into as many equal parts as the denominator of the fraction.



Think about it.

If we want to show the fractions $\frac{3}{10}$, $\frac{9}{20}$, $\frac{19}{40}$ on the number line, how big should the unit be?

Practice Set 11

1. What fractions do the points A and B show on the number lines below?

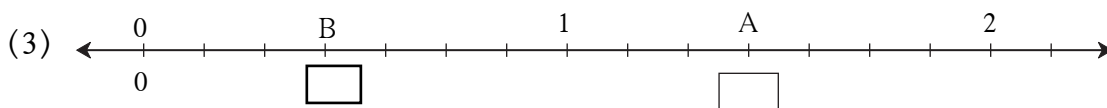
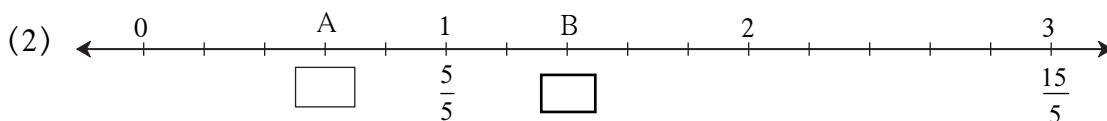
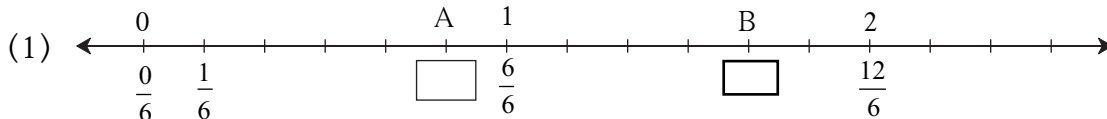

2. Show the following fractions on the number line.

(1) $\frac{3}{5}$, $\frac{6}{5}$, $2\frac{3}{5}$ (2) $\frac{3}{4}$, $\frac{5}{4}$, $2\frac{1}{4}$



Multiplication of Fractions

See how the multiplication $\frac{3}{5} \times \frac{1}{2}$ is done with the help of the rectangular strip.

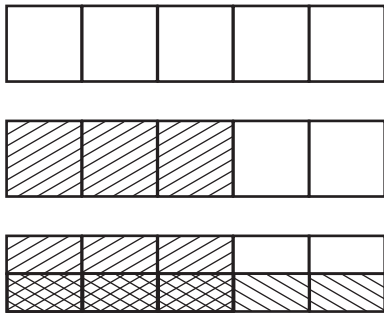

- Draw vertical lines to divide a rectangular strip into 5 equal parts.
- Shade the part that shows the fraction $\frac{3}{5}$.
- We have to show $\frac{1}{2}$ of $\frac{3}{5}$. So, draw a horizontal line to divide the strip into two equal parts.

- Shade one of the two horizontal parts in a different way.

When we divided the strip into 2 equal parts, we also divided the $\frac{3}{5}$ part into 2 equal parts. To take one of those parts, consider the parts shaded twice.

We have 10 equal boxes. Of these, 3 boxes have been shaded twice.

These boxes, i.e., the part shaded twice can be written as the fraction $\frac{3}{10}$.

$$\frac{3}{5} \times \frac{1}{2} = \frac{3}{10}$$

We can carry out the above multiplication like this : $\frac{3}{5} \times \frac{1}{2} = \frac{3 \times 1}{5 \times 2} = \frac{3}{10}$



When multiplying two fractions, the product of the numerators is written in the numerator and that of the denominators, in the denominator.

Example : Sulochanabai owns 42 acres of farm land. If she planted wheat on $\frac{2}{7}$ of the land, on how many acres has she planted wheat?

We must find out $\frac{2}{7}$ of 42 acres $\therefore \frac{42}{1} \times \frac{2}{7} = \frac{42 \times 2}{1 \times 7} = \frac{6 \times 7 \times 2}{7} = 12$

Sulochanabai has planted wheat on 12 acres of land.

Practice Set 12

1. Multiply.

(i) $\frac{7}{5} \times \frac{1}{4}$

(ii) $\frac{6}{7} \times \frac{2}{5}$

(iii) $\frac{5}{9} \times \frac{4}{9}$

(iv) $\frac{4}{11} \times \frac{2}{7}$

(v) $\frac{1}{5} \times \frac{7}{2}$

(vi) $\frac{9}{7} \times \frac{7}{8}$

(vii) $\frac{5}{6} \times \frac{6}{5}$

(viii) $\frac{6}{17} \times \frac{3}{2}$

2. Ashokrao planted bananas on $\frac{2}{7}$ of his field of 21 acres. What is the area of the banana plantation?

3* Of the total number of soldiers in our army, $\frac{4}{9}$ are posted on the northern border and one-third of them on the north-eastern border. If the number of soldiers in the north is 540000, how many are posted in the north-east?



Let's learn.

Reciprocals or Multiplicative Inverses

Look at these multiplications.

(1) $\frac{5}{6} \times \frac{6}{5} = \frac{30}{30} = 1$

(2) $4 \times \frac{1}{4} = \frac{4}{1} \times \frac{1}{4} = \frac{4}{4} = 1$

(3) $\frac{3}{2} \times \frac{2}{3} = \frac{6}{6} = 1$

(4) $\frac{71}{3} \times \frac{3}{71} = 1$

What is the peculiarity you see in all of them?

A fraction is multiplied by another fraction obtained by exchanging the numerator and denominator of the first fraction. Their product is 1. Each fraction of such a pair is called the reciprocal or multiplicative inverse of the other.

Example : The multiplicative inverse or reciprocal of $\frac{5}{6}$ is $\frac{6}{5}$.

The multiplicative inverse of 4, that is, of $\frac{4}{1}$ is $\frac{1}{4}$.



Now I know -

When the product of two numbers is 1, each of the numbers is the multiplicative inverse or reciprocal of the other.



Think about it.

(1) What is the reciprocal of 1?

(2) Would 0 have a reciprocal?



Let's learn.

Division of Fractions

Example : Here is one bhakari. If each one is to be given a quarter of it, how many will get a share?



A quarter means $\frac{1}{4}$.

As we can see in the picture, we can get 4 quarters from one bhakari, so it will be enough for four people.

We can write this as $4 \times \frac{1}{4} = 1$.

Now, we shall convert the division of a fraction into a multiplication.

$$1 \div \frac{1}{4} = 4 = 1 \times \frac{4}{1}$$

Example : There are 6 blocks of jaggery, each of one kilogram. If one family requires one and a half kg jaggery every month, for how many families will these blocks suffice?

$$\text{One and a half is } 1 + \frac{1}{2} = \frac{3}{2}$$

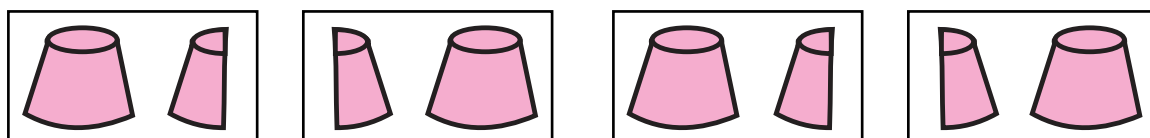

Let us divide to see how many families can share the jaggery.

$$6 \div \frac{3}{2} = \frac{6}{1} \div \frac{3}{2} = \frac{6}{1} \times \frac{2}{3} = 4 \quad \text{Therefore, 6 blocks will suffice for 4 families.}$$

$$\text{Example : } 12 \div 4 = \frac{12}{1} \times \frac{1}{4} = \frac{12}{4} = 3$$

$$\text{Example : } \frac{5}{7} \div \frac{2}{3} = \frac{5}{7} \times \frac{3}{2} = \frac{5 \times 3}{7 \times 2} = \frac{15}{14} = 1 \frac{1}{14}$$



Now I know -

To divide a number by a fraction is to multiply it by the reciprocal of the fraction.

Practice Set 13

1. Write the reciprocals of the following numbers.

(i) 7

(ii) $\frac{11}{3}$

(iii) $\frac{5}{13}$

(iv) 2

(v) $\frac{6}{7}$

2. Carry out the following divisions.

(i) $\frac{2}{3} \div \frac{1}{4}$

(ii) $\frac{5}{9} \div \frac{3}{2}$

(iii) $\frac{3}{7} \div \frac{5}{11}$

(iv) $\frac{11}{12} \div \frac{4}{7}$

3* There were 420 students participating in the Swachh Bharat campaign. They cleaned $\frac{42}{75}$ part of the town, Sevagram. What part of Sevagram did each student clean if the work was equally shared by all?



Ramanujan's Magic Square

| | | | |
|----|----|----|----|
| 22 | 12 | 18 | 87 |
| 88 | 17 | 9 | 25 |
| 10 | 24 | 89 | 16 |
| 19 | 86 | 23 | 11 |

- Add the four numbers in the rows, the columns and along the diagonals of this square.
- What is the sum?
- Is it the same every time?
- What is the peculiarity?
- Look at the numbers in the first row.
 $22 - 12 = 1887$
Find out why this date is special.

Obtain and read a biography of the great Indian mathematician Srinivasa Ramanujan.



Now to find out the total weight of the vegetables, let us add using both units, kilograms and grams, in turn.



| | | | |
|--------------|------------|--------------|------------|
| Potatoes | 750 g | Potatoes | 0.750 kg |
| Onions | + 1000 g | Onions | + 1.000 kg |
| Cabbage | + 500 g | Cabbage | + 0.500 kg |
| Tomatoes | + 250 g | Tomatoes | + 0.250 kg |
| <hr/> | | <hr/> | |
| Total weight | 2500 grams | Total weight | 2.500 kg |

Note the similarity between the addition of integers and the addition of decimal fractions.

Total weight of vegetables is 2500 g, that is $\frac{2500}{1000}$ kg, that is 2.500 kg.

We know that, $2.500 = 2.50 = 2.5$

The weight of vegetables in Reshma's bag is 2.5 kg.



My friend, Maths : At the market, in the shop.

Take a pen and notebook with you when you go to the market with your parents. Note the weight of every vegetable your mother buys. Find out the total weight of those vegetables.

Practice Set 14

1. In the table below, write the place value of each of the digits in the number 378.025.

| Place | Hundreds | Tens | Units | Tenths | Hundredths | Thousandths |
|-------------|----------|------|-------|--------------------|-----------------|--------------------------|
| | 100 | 10 | 1 | $\frac{1}{10}$ | $\frac{1}{100}$ | $\frac{1}{1000}$ |
| Digit | 3 | 7 | 8 | 0 | 2 | 5 |
| Place value | 300 | | | $\frac{0}{10} = 0$ | | $\frac{5}{1000} = 0.005$ |

2. Solve.

(1) $905.5 + 27.197$

(2) $39 + 700.65$

(3) $40 + 27.7 + 2.451$

3. Subtract.

(1) $85.96 - 2.345$

(2) $632.24 - 97.45$

(3) $200.005 - 17.186$

4. Avinash travelled 42 km 365 m by bus, 12 km 460 m by car and walked 640 m. How many kilometres did he travel altogether? (Write your answer in decimal fractions.)
5. Ayesha bought 1.80 m of cloth for her salwaar and 2.25 m for her kurta. If the cloth costs 120 rupees per metre, how much must she pay the shopkeeper?
6. Sujata bought a watermelon weighing 4.25 kg and gave 1 kg 750g to the children in her neighbourhood. How much of it does she have left?
7. Anita was driving at a speed of 85.6 km per hour. The road had a speed limit of 55 km per hour. By how much should she reduce her speed to be within the speed limit?



Let's recall.

Showing Decimal Fractions on the Number Line

Example : Observe how the numbers 0.7 and 6.5 are marked on the number line.

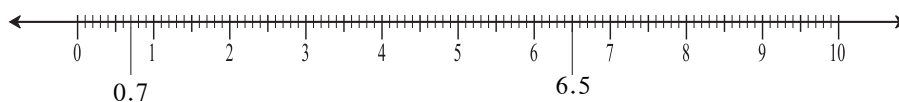

In the same way, show the following numbers on the number line.

- (1) 3.5 (2) 0.8 (3) 1.9 (4) 4.2 (5) 2.7



Let's learn.

Converting a Common Fraction into a Decimal Fraction

You know that if the denominator of a common fraction is 10 or 100, it can be written as a decimal fraction.

Can you recall how to convert the fractions $\frac{1}{2}$, $\frac{1}{4}$, $\frac{2}{5}$ into decimal fractions?

A fraction whose denominator is 1000 can also be written as a decimal fraction. Let us see how.

If the denominator of a common fraction is 10, 100, 1000, then -

- (1) If there are more digits in the numerator than zeros in the denominator, then count as many digits from the right as the number of zeros, and place the decimal point before those digits.

Examples (1) $\frac{723}{10} = 72.3$ (2) $\frac{51250}{100} = 512.50$ (3) $\frac{5138}{1000} = 5.138$

(2) If there are as many digits in the numerator as zeros in the denominator, place the decimal point before the number in the numerator and a zero in the integers' place.

Examples (1) $\frac{7}{10} = 0.7$ (2) $\frac{54}{100} = 0.54$ (3) $\frac{725}{1000} = 0.725$

(3) If there are fewer digits in the numerator than the zeros in the denominator, place zeros before the digits in the numerator to make the total number of digits equal to the number of zeros in the denominator. Place a decimal point before them and a zero in the integers' place.

Examples (1) $\frac{8}{100} = \frac{08}{100} = 0.08$ (2) $\frac{8}{1000} = \frac{008}{1000} = 0.008$



Let's learn.

Converting a Decimal Fraction into a Common Fraction

(1) $26.4 = \frac{264}{10}$ (2) $0.04 = \frac{4}{100}$ (3) $19.315 = \frac{19315}{1000}$



Now I know -

This is how we convert a decimal fraction into a common fraction. In the numerator, we write the number we get by ignoring the decimal point. In the denominator, we write 1 followed by as many zeros as there are decimal places in the given number.

Practice Set 15

1. Write the proper number in the empty boxes.

(1) $\frac{3}{5} = \frac{3 \times \square}{5 \times \square} = \frac{\square}{10} = \square$ (2) $\frac{25}{8} = \frac{25 \times \square}{8 \times 125} = \frac{\square}{1000} = 3.125$

(3) $\frac{21}{2} = \frac{21 \times \square}{2 \times \square} = \frac{\square}{10} = \square$ (4) $\frac{22}{40} = \frac{11}{20} = \frac{11 \times \square}{20 \times 5} = \frac{\square}{100} = \square$

2. Convert the common fractions into decimal fractions.

(1) $\frac{3}{4}$ (2) $\frac{4}{5}$ (3) $\frac{9}{8}$ (4) $\frac{17}{20}$ (5) $\frac{36}{40}$ (6) $\frac{7}{25}$ (7) $\frac{19}{200}$

3. Convert the decimal fractions into common fractions.

(1) 27.5 (2) 0.007 (3) 90.8 (4) 39.15 (5) 3.12 (6) 70.400



Let's learn.

Multiplication of Decimal Fractions

Example 1. Multiply 4.3×5 .

| Method I | Method II | Method III | | | | | | | | | |
|--|--|-----------------|---|----------------|---|----|-----------------|--|----|-----|--|
| $4.3 \times 5 = \frac{43}{10} \times \frac{5}{1}$ $= \frac{43 \times 5}{10 \times 1}$ $= \frac{215}{10}$ $4.3 \times 5 = 21.5$ | <table border="1"> <tr> <td>×</td> <td>4</td> <td>$\frac{3}{10}$</td> </tr> <tr> <td>5</td> <td>20</td> <td>$\frac{15}{10}$</td> </tr> <tr> <td></td> <td>20</td> <td>1.5</td> </tr> </table> $4.3 \times 5 = 20 + 1.5 = 21.5$ | × | 4 | $\frac{3}{10}$ | 5 | 20 | $\frac{15}{10}$ | | 20 | 1.5 | $\begin{array}{r} 43 \\ \times 5 \\ \hline 215 \end{array}$ $\begin{array}{r} 4.3 \\ \times 5 \\ \hline 21.5 \end{array}$ |
| × | 4 | $\frac{3}{10}$ | | | | | | | | | |
| 5 | 20 | $\frac{15}{10}$ | | | | | | | | | |
| | 20 | 1.5 | | | | | | | | | |

Example 2.

The rate of petrol is ₹ 62.32 per litre. Seema wants to fill two and a half litres of petrol in her scooter. How many rupees will she have to pay?

Which operation is required?



Method I

$$62.32 \times 2.5 = ?$$

$$62.32 \times 2.5 = \frac{6232}{100} \times \frac{25}{10}$$

$$= \frac{155800}{1000}$$

$$= 155.800$$

Seema will have to pay ₹155.80

Method II

| | |
|---|--|
| $\begin{array}{r} 6232 \\ \times 25 \\ \hline 155800 \end{array}$ | $\begin{array}{r} 62.32 \\ \times 2.5 \\ \hline 155.800 \end{array}$ |
|---|--|

- First, multiply ignoring the decimal point.
- Then, in the product, starting from the units place, we count as many places as the total decimal places in the multiplicand and multiplier, and place the decimal point before them.

Practice Set 16

- If, $317 \times 45 = 14265$, then $3.17 \times 4.5 = ?$
- If, $503 \times 217 = 109151$, then $5.03 \times 2.17 = ?$
- Multiply.

| | | | |
|----------------------|-----------------------|---------------------|-----------------------|
| (1) 2.7×1.4 | (2) 6.17×3.9 | (3) 0.57×2 | (4) 5.04×0.7 |
|----------------------|-----------------------|---------------------|-----------------------|

- Virendra bought 18 bags of rice, each bag weighing 5.250 kg. How much rice did he buy altogether? If the rice costs 42 rupees per kg, how much did he pay for it?
- Vedika has 23.50 metres of cloth. She used it to make 5 curtains of equal size. If each curtain required 4 metres 25 cm to make, how much cloth is left over?



Let's learn.

We have seen that $\frac{5}{7} \div \frac{2}{3} = \frac{5}{7} \times \frac{3}{2} = \frac{15}{14}$

Division of Decimal Fractions

$$(1) 6.2 \div 2 = \frac{62}{10} \div \frac{2}{1} = \frac{62}{10} \times \frac{1}{2} = \frac{31}{10} = 3.1$$

$$(2) 3.4 \div 5 = \frac{34}{10} \div \frac{5}{1} = \frac{34}{10} \times \frac{1}{5} = \frac{34}{50} = \frac{34 \times 2}{50 \times 2} = \frac{68}{100} = 0.68$$

$$(3) 4.8 \div 1.2 = \frac{48}{10} \div \frac{12}{10} = \frac{48}{10} \times \frac{10}{12} = 4$$

Practice Set 17

- Carry out the following divisions.
 - $4.8 \div 2$
 - $17.5 \div 5$
 - $20.6 \div 2$
 - $32.5 \div 25$
- A road is 4 km 800 m long. If trees are planted on both its sides at intervals of 9.6 m, how many trees were planted?
- Pradnya exercises regularly by walking along a circular path on a field. If she walks a distance of 3.825 km in 9 rounds of the path, how much does she walk in one round?
- A pharmaceutical manufacturer bought 0.25 quintal of *hirada*, a medicinal plant, for 9500 rupees. What is the cost per quintal of *hirada*? (1quintal = 100 kg)



Maths is fun!

Hamid : Salma, tell me any three-digit number.

Salma : Ok, here's one, five hundred and twenty-seven.

Hamid : Now multiply the number by 7. Then multiply the product obtained by 13, and this product, by 11.

Salma : Hm, I did it.

Hamid : Your answer is five lakh twenty-seven thousand five hundred and twenty-seven.

Salma : Wow! How did you do that so quickly?

Hamid : Take two or three other numbers. Do the same multiplications and find out how it's done!





Let's recall.

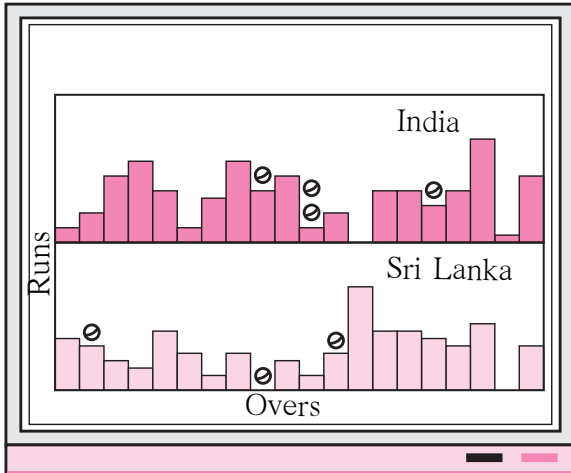

Observe the picture alongside.

- (1) To which sport is this data related?
- (2) How many things does the picture tell us about?
- (3) What shape has been used in the picture to represent runs?

We have seen how to make pictograms for given numerical data. When the scale is given, numerical information can be obtained by counting the pictures.

Example : A pictogram of the types and numbers of vehicles in a town is given below. Taking 1 picture = 5 vehicles, write their number in the pictogram.

| Type of vehicle | Vehicles | Number |
|-----------------|----------|--------|
| Bicycle | | |
| Motor-cycle | | |
| Auto-rickshaw | | |
| Bullock cart | | |

It can take a long time to draw pictures. Could we give the same data without using pictures?



Let's learn.

Graph Paper

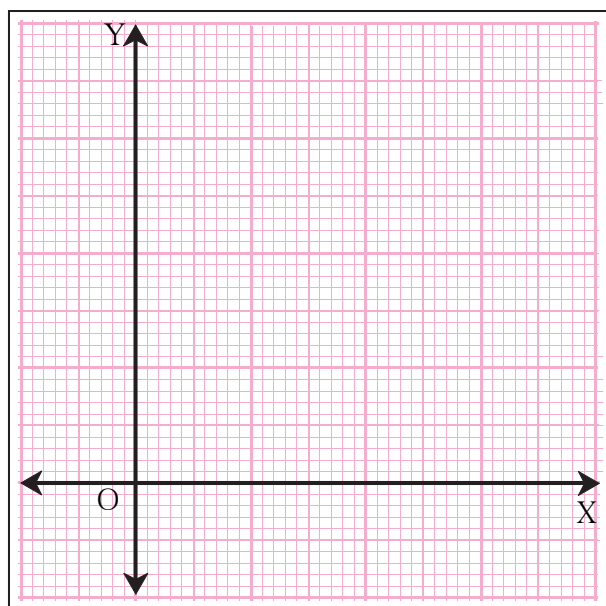

Observe the graph paper shown here. There are some bold and some faint lines on it. The bold lines show a certain big unit. This unit is divided into smaller units which are shown by the faint lines. The grid formed by these lines makes it easy to select a suitable scale and draw columns of the proper height.

Near the lower edge of the paper, a horizontal line is drawn as a base. It is called the X-axis. A line perpendicular to the X-axis is drawn on the left side of the paper. That is called the Y-axis.

The items about which the graph is to be drawn are taken on the X-axis at equal distances from each other. The number related to each item is shown above it by a vertical column. This column is parallel to the Y-axis and of the proper height according to the chosen scale. Now, let us convert the pictogram shown on page 35 into a bar graph.

In the graph, we have to show certain vehicles and their number, which are 5, 15, 25 and 30. Let us take a scale of 5 vehicles = 1 big unit.

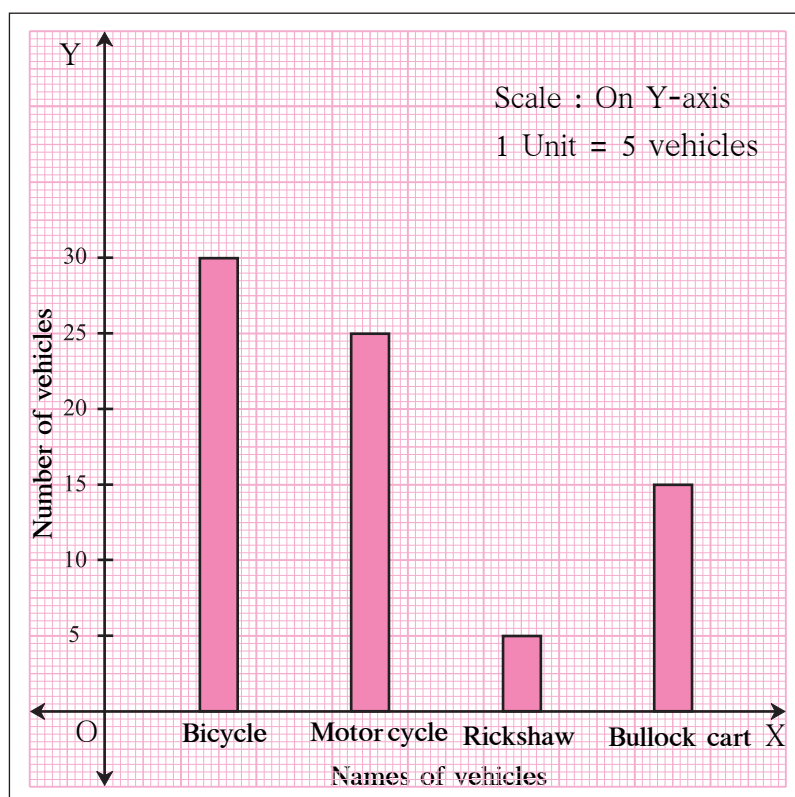

You can see the finished graph in the figure above.

Practice Set 18

* This bar graph shows the maximum temperatures in degrees Celsius in different cities on a certain day in February. Observe the graph and answer the questions.

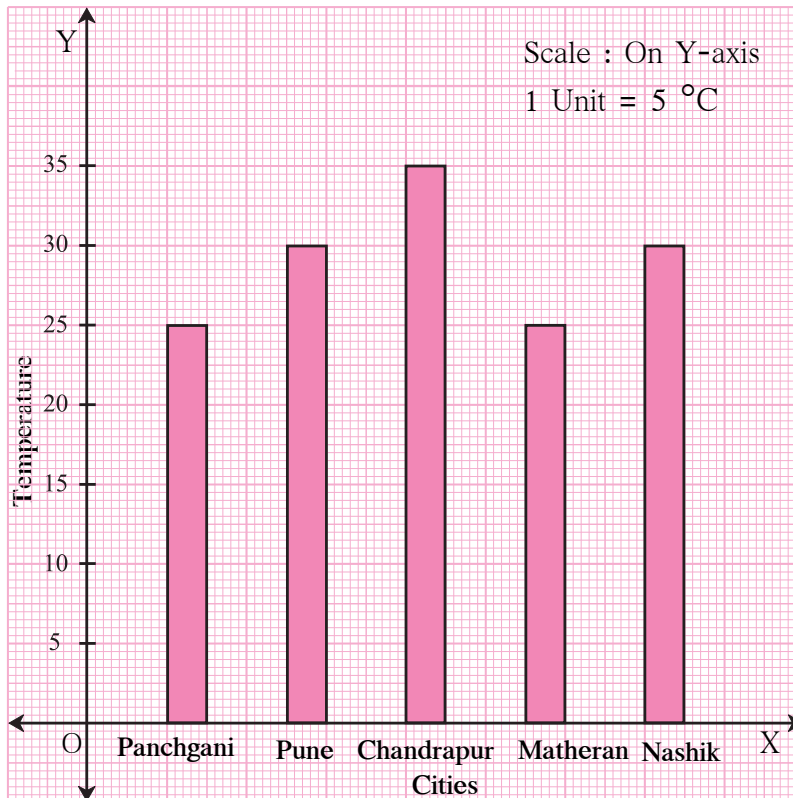

- (1) What data is shown on the vertical and the horizontal lines?
- (2) Which city had the highest temperature?
- (3) Which cities had equal maximum temperatures?
- (4) Which cities had a maximum temperature of 30°C?
- (5) What is the difference between the maximum temperatures of Panchgani and Chandrapur?



Let's learn.

Drawing a Bar Graph

Let us take an example to see how the given data is shown as a bar graph.

Example : Information about the plants in a nursery is given here. Show it in a bar graph.

| | | | | |
|-------------------------|--------|-----|----------|---------------|
| Names of plants | Mogara | Jai | Hibiscus | Chrysanthemum |
| Number of plants | 70 | 50 | 45 | 80 |

Take a graph paper.

- (1) In the centre, write the title 'Types and number of plants'.
- (2) Draw the X and Y axes, and mark O, their point of intersection.
- (3) Write the names of the plants on the X-axis at equal distances.
- (4) The number of plants is divisible by 5. So, take the scale 0.5 cm = 5 plants, that is, 1cm = 10 plants on the Y-axis as it can be easily shown on the graph paper.
- (5) Write the scale in the top right hand corner.
- (6) Draw a bar of the appropriate height above the name of each plant on the X-axis.

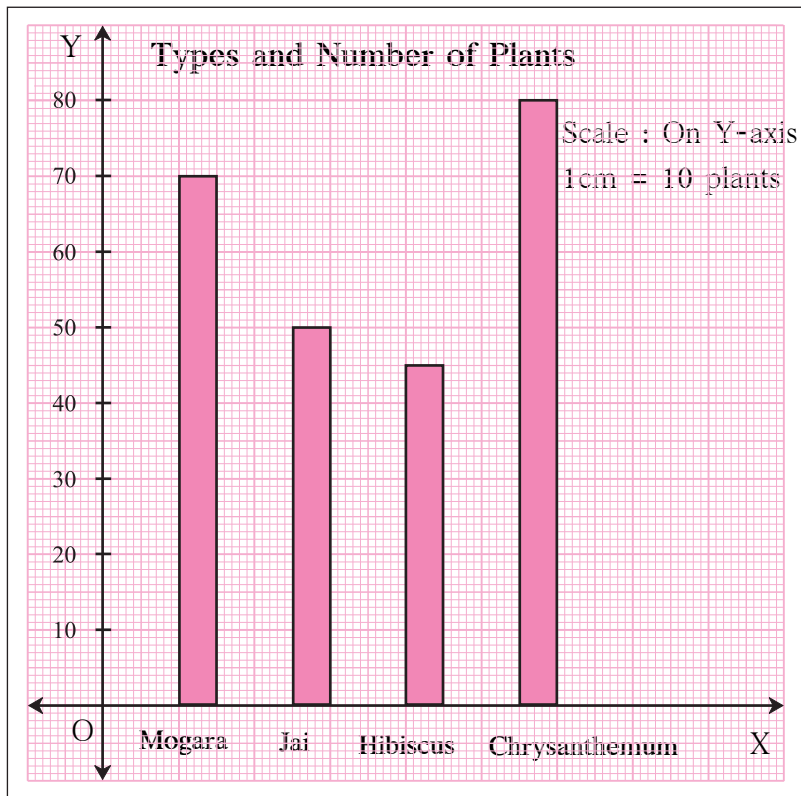

For the same example above, draw a graph taking a different scale on the Y-axis. (For example, 1 cm = 5 plants.) Compare it with the graph above.



Now I know -

- Every bar in the graph should be of equal width.
- The distance between any two adjacent bars should be equal.
- All bars should be of appropriate height.



My friend, Maths : In newspapers, in periodicals.

Collect bar graphs from newspapers or periodicals showing a variety of data.

Practice Set 19

- (1) The names of the heads of some families in a village and the quantity of drinking water their family consumes in one day are given below. Draw a bar graph for this data.

(Scale : On Y-axis, 1cm = 10 litres of water)

| Name | Ramesh | Shobha | Ayub | Julie | Rahul |
|----------------------|-----------|-----------|-----------|-----------|-----------|
| Litres of water used | 30 litres | 60 litres | 40 litres | 50 litres | 55 litres |

- (2) The names and numbers of animals in a certain zoo are given below. Use the data to make a bar graph. (Scale : on Y-axis, 1cm = 4 animals)

| Animals | Deer | Tiger | Monkey | Rabbit | Peacock |
|---------|------|-------|--------|--------|---------|
| Number | 20 | 4 | 12 | 16 | 8 |

- (3) The table below gives the number of children who took part in the various items of the talent show as part of the the annual school gathering. Make a bar graph to show this data. (Scale : on Y-axis, 1cm = 4 children)

| Programme | Theatre | Dance | Vocal music | Instrumental music | One-act plays |
|-----------------|---------|-------|-------------|--------------------|---------------|
| No. of students | 24 | 40 | 16 | 8 | 4 |

- (4) The number of customers who came to a juice centre during one week is given in the table below. Make two different bar graphs to show this data.

(Scale : on Y-axis, 1cm = 10 customers, on Y-axis, 1cm = 5 customers)

| Type of juice | Orange | Pineapple | Apple | Mango | Pomegranate |
|------------------|--------|-----------|-------|-------|-------------|
| No. of customers | 50 | 30 | 25 | 65 | 10 |

- (5)* Students planted trees in 5 villages of Sangli district. Make a bar graph of this data. (Scale : on Y-axis, 1cm = 100 trees)

| Name of place | Dudhgaon | Bagni | Samdoli | Ashta | Kavathepiran |
|----------------------|----------|-------|---------|-------|--------------|
| No. of trees planted | 500 | 350 | 600 | 420 | 540 |

- (6)* Yashwant gives different amounts of time as shown below, to different exercises he does during the week. Draw a bar graph to show the details of his schedule using an appropriate scale.

| Type of exercise | Running | Yogasanas | Cycling | Mountaineering | Badminton |
|------------------|------------|------------|-------------|-----------------------|------------|
| Time | 35 minutes | 50 minutes | 1 hr 10 min | 1 $\frac{1}{2}$ hours | 45 minutes |

- (7) Write the names of four of your classmates. Beside each name, write his/her weight in kilograms. Enter this data in a table like the above and make a bar graph.



ICT Tools or Links

Several different types of graphs are used to present numerical data. Ask your teacher for help to observe the graphs in MS - Excel, PPT.

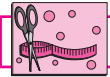

Try this.

Activity : Take a paper and fold it so that it gets divided into two equal parts and unfold it. Make a blob of colour on one of the parts. Fold the paper again and press it a little. Now, unfold it. What do you see? The shape obtained is symmetrical about the line of the fold.

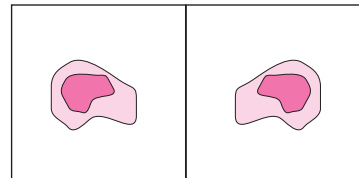

Activity : Now take a paper and a length of thread. Dip the thread in colour. Place it on one side of the paper. Fold the paper over it. Keeping the folded paper pressed down, pull out the thread by one of its ends. Unfold the paper. You will see a picture. The shape on the other side of the line will be like the one on the first. The picture that is formed is said to be symmetrical.

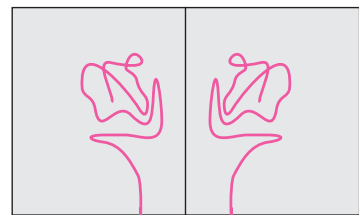

Think about it.

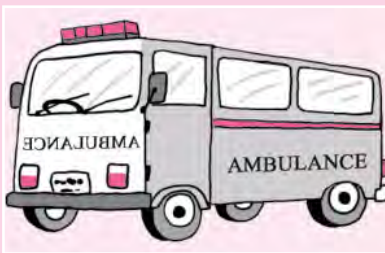

Do you recognize this picture?

Why do you think the letters written on the front of the vehicle are written the way they are? Copy them on a paper. Hold the paper in front of a mirror and read it.

Do you see letters written like this anywhere else?

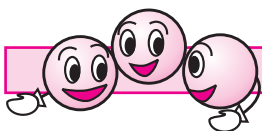

Let's discuss.

Teacher : Anil, Sudha, we can see ourselves in the mirror. That is our image. What is different about it?

Sudha : I have pinned my badge on my left. But, it appears on the right in the image.

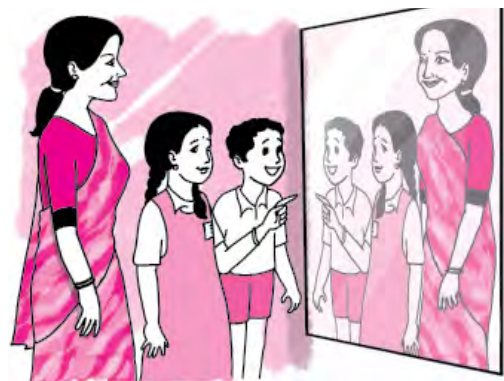

Anil : My image in the mirror is as far behind in the mirror as I am in front of it.

Sudha : Teacher's *pallu* is on her left shoulder. But in the mirror it appears to be on her right shoulder.

Teacher : We and our images are symmetrical with reference to the mirror.



Let's learn.

Reflectional Symmetry

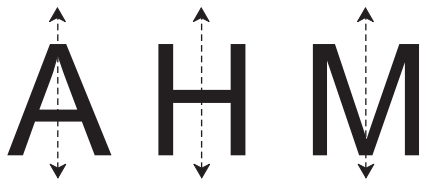

Write the English capital letters A, H, M in a large size on separate sheets of paper. Fold the paper so that their two parts fall exactly on each other. Mark with dots the line which makes two equal parts of the figure. This line is the **axis of symmetry** of the figure.

If a symmetrical figure gets divided by an axis in the figure into two parts which fall exactly on each other, its symmetry is called **reflectional symmetry**. Some figures have more than one axis of symmetry.

The figures below are symmetrical.

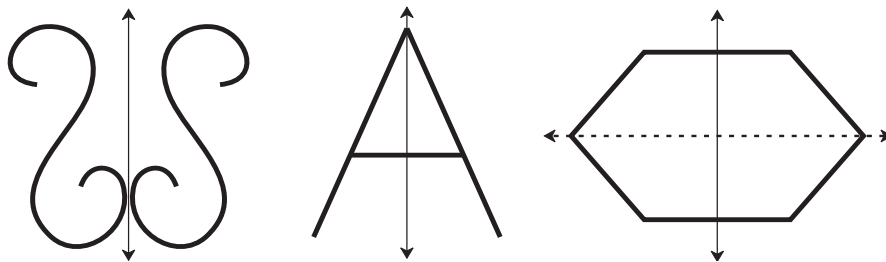

Practice Set 20

(1) Draw the axes of symmetry of each of the figures below. Which of them has more than one axis of symmetry?

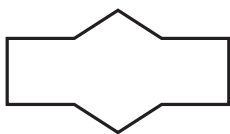

(1)

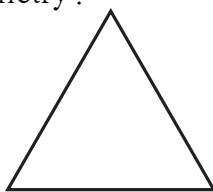

(2)



(3)

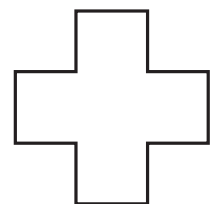

(4)

(2) Write the capital letters of the English alphabet in your notebook. Try to draw their axes of symmetry. Which ones have an axis of symmetry? Which ones have more than one axis of symmetry?

(3) Use colour, a thread and a folded paper to draw symmetrical shapes.

(4) Observe various commonly seen objects such as tree leaves, birds in flight, pictures of historical buildings, etc. Find symmetrical shapes among them and make a collection of them.

Drawing symmetrical figures on graph paper

Observe the figure on the graph paper. The line segment AB is drawn on the left of the line l . The points A' and B' are as far on the right of l as A and B are on its left. The points A' and B' are the images of points A and B . The figure, segment $A'B'$, is the image of the segment AB . Verify by measuring the lengths of seg AB and seg $A'B'$.

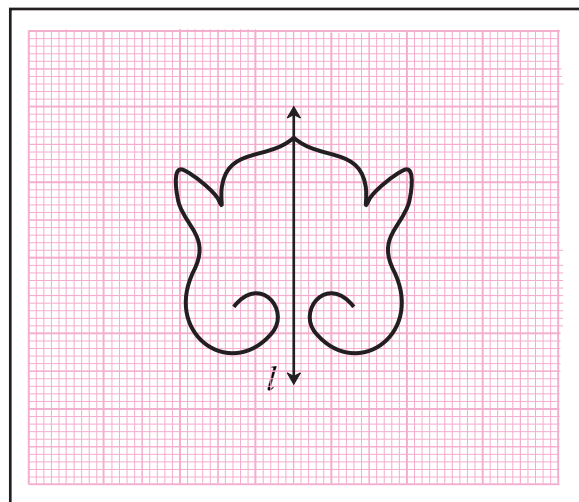
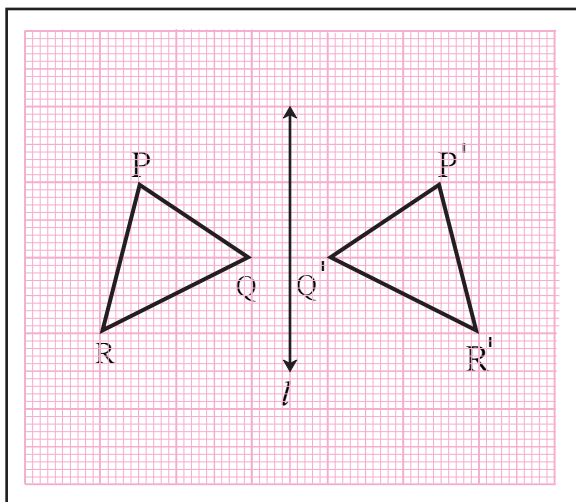
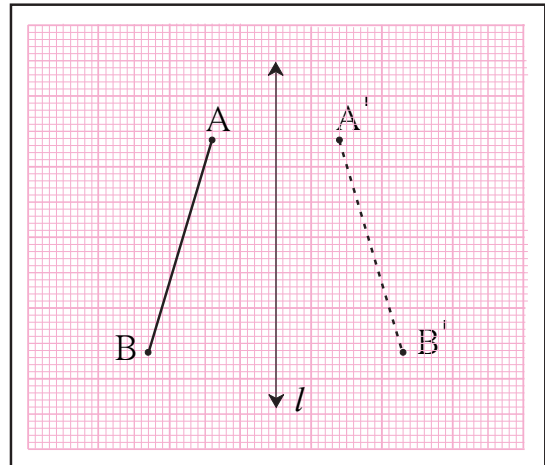

In the figures above, the line l divides the figure into two parts. Do these two parts fall exactly on each other? Verify.

Practice Set 21

- ★ Along each figure shown below, a line l has been drawn. Complete the symmetrical figures by drawing a figure on the other side such that the line l becomes the line of symmetry.

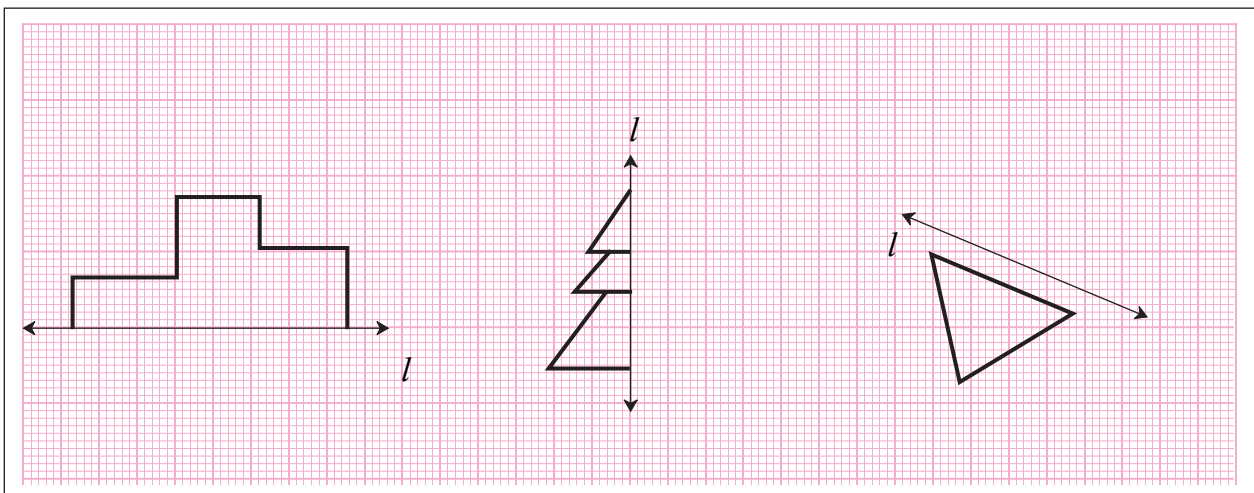



Let's recall.

- Write the divisibility tests for 2, 5 and 10.
- Read the numbers given below. Which of these numbers are divisible by 2, by 5 or by 10? Write them in the empty boxes.

125, 364, 475, 750, 800, 628, 206, 508, 7009, 5345, 8710

Divisible by 2

Divisible by 5

Divisible by 10



Let's learn.

Divisibility Tests

Let us study some more tests.

Complete the table below.

| Number | Sum of the digits in the number | Is the sum divisible by 3? | Is the given number divisible by 3? |
|--------|---------------------------------|----------------------------|-------------------------------------|
| 63 | $6 + 3 = 9$ | ✓ | ✓ |
| 872 | 17 | × | × |
| 91 | | | |
| 552 | | | |
| 9336 | | | |
| 4527 | | | |

What can we conclude from this?



Now I know -

Divisibility test for 3 : If the sum of the digits in a number is divisible by 3, then the number is divisible by 3.



Let's learn.

Complete the following table.

| Number | Divide the number by 4. Is it completely divisible? | The number formed by the digits in the tens and units places | Is this number divisible by 4? |
|--------|--|--|--------------------------------|
| 992 | ✓ | 92 | ✓ |
| 7314 | | | |
| 6448 | | | |
| 8116 | | | |
| 7773 | | | |
| 3024 | | | |

What can we conclude from this?



Now I know -

Divisibility test for 4 : If the number formed by the digits in the tens and units places of the number is divisible by 4, then that number is divisible by 4.



Let's learn.

Complete the following table.

| Number | Divide the number by 9. Is it completely divisible? | Sum of the digits in the number | Is the sum divisible by 9? |
|--------|---|---------------------------------|----------------------------|
| 1980 | ✓ | $1 + 9 + 8 + 0 = 18$ | ✓ |
| 2999 | × | 29 | × |
| 5004 | | | |
| 13389 | | | |
| 7578 | | | |
| 69993 | | | |

What can we conclude from this?





Now I know -

Divisibility test for 9 : If the sum of the digits of a number is completely divisible by 9, then the number is divisible by 9.

Practice Set 22

- ★ There are some flowering trees in a garden. Each tree bears many flowers with the same number printed on it. Three children took a basket each to pick flowers. Each basket has one of the numbers, 3, 4 or 9 on it. Each child picks those flowers which have numbers divisible by the number on his or her basket. He/She takes only 1 flower from each tree. Can you tell which numbers the flowers in each basket will have ?

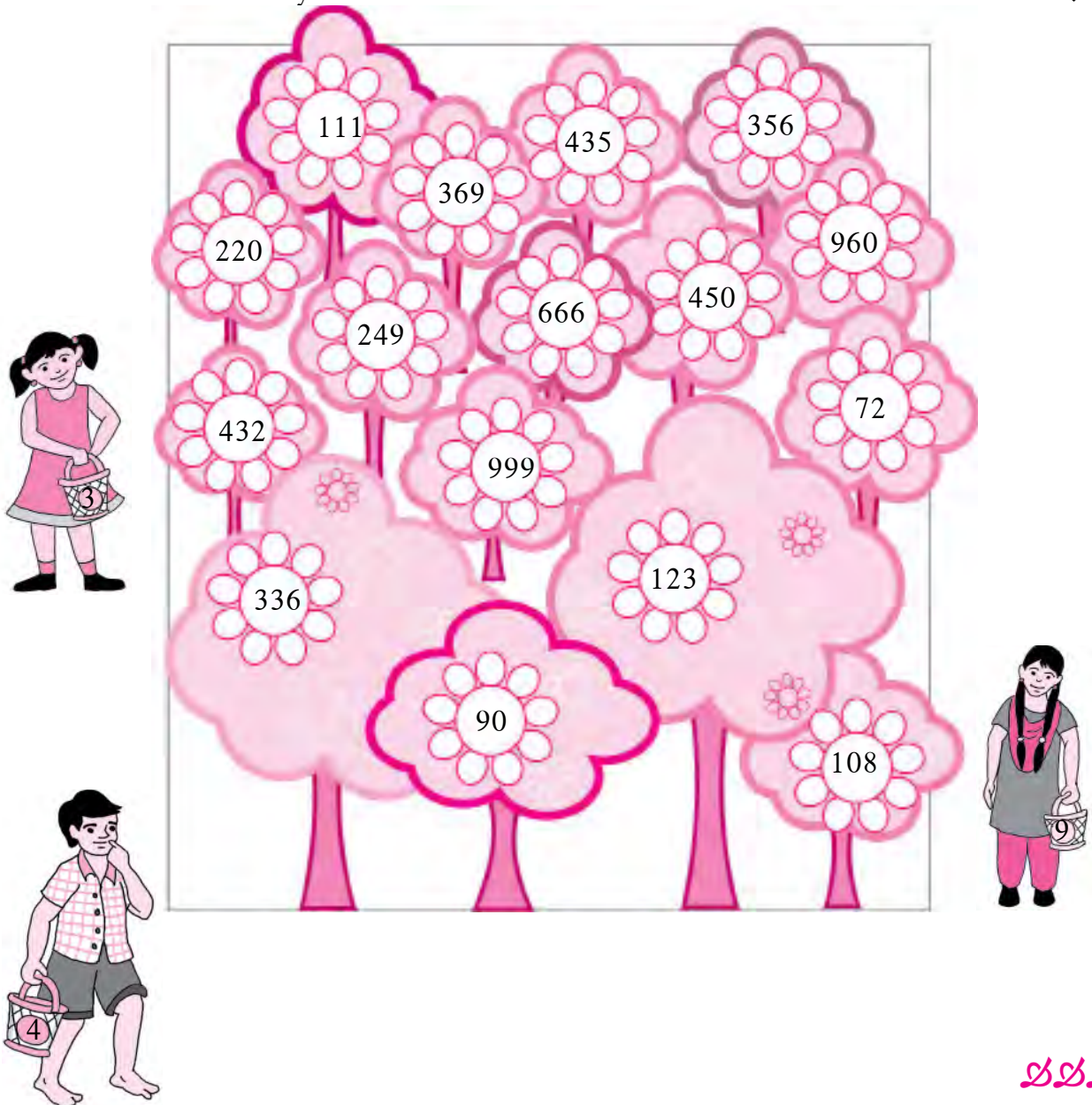



Let's recall.

Divisor, Dividend

In the empty boxes, write the proper words : dividend, divisor, quotient, remainder.

$$\begin{array}{r} \square \leftarrow 4 \overline{)36} \rightarrow \begin{array}{l} \square \\ \square \end{array} \\ \underline{36} \\ 00 \rightarrow \square \end{array}$$

$$\begin{array}{r} \square \leftarrow 9 \overline{)65} \rightarrow \begin{array}{l} \square \\ \square \end{array} \\ \underline{63} \\ 02 \rightarrow \square \end{array}$$

When we divide 36 by 4, the remainder is zero. Therefore, 4 is a **factor** of 36 and 36 is a **multiple** of 4. (36 is divisible by 4.)

When we divide 65 by 9, the remainder is not zero. Therefore, 9 is not a **factor** of 65. Also, 65 is not a **multiple** of 9. (65 is not divisible by 9.)

Factors of 36 : 1, 2, 3, 4, 6, 9, 12, 18, 36

Factors of 48 : 1, 2, 3, 4, 6, 8, 12, 16, 24, 48

Write the common factors. , , , , ,

Practice Set 23

* Write all the factors of the given numbers and list their common factors.

(1) 12, 16

(2) 21, 24

(3) 25, 30

(4) 24, 25

(5) 56, 72



Let's learn.

Highest Common Factor : HCF

Example : My aunt has brought two ribbons of different colours, one 12 metres long and the other 18 metres. Both the ribbons have to be cut into pieces of the same length. What should be the maximum length of each piece?



The number which gives the length of each piece must be a factor of 12 and of 18.

Factors of 12 : 1, 2, 3, 4, , 12

Factors of 18 : 1, 2, 3, , 9, 18

Of the common factors of 12 and 18, 6 is the greatest. Therefore, the maximum length of each piece should be 6 metres.

Example : There are 20 kg of jowar and 50 kg of wheat in a shop. All the grain is to be packed in bags. If all the bags are to have equal weights of grain, what is the maximum weight of grain that can be filled in each bag ?

The weight of the grain in each bag must be a factor of 20 and 50. Besides, the maximum possible weight must be filled in each bag. Hence, let us find the HCF of 20 and 50.

Factors of 20 : 1, 2, 4, 5, 10, 20

Factors of 50 : 1, 2, 5, 10, 25, 50

Common factors : 1, 2, 5, 10

Of the common factors of 20 and 50, 10 is the greatest, i.e. 10 is the HCF of the numbers 20 and 50.

Therefore, a maximum of 10 kg of grain can be filled in each bag.



Now I know –

To find the HCF of given numbers, we make a list of the factors of the numbers and find the greatest of the common factors.

Practice Set 24

- Find the HCF of the following numbers.
(1) 45, 30 (2) 16, 48 (3) 39, 25 (4) 49, 56 (5) 120, 144
(6) 81, 99 (7) 24, 36 (8) 25, 75 (9) 48, 54 (10) 150, 225
- If large square beds of equal size are to be made for planting vegetables on a plot of land 18 metres long and 15 metres wide, what is the maximum possible length of each bed ?
- Two ropes, one 8 metres long and the other 12 metres long are to be cut into pieces of the same length. What will the maximum possible length of each piece be ?
- The number of students of Std 6th and Std 7th who went to visit the Tadoba Tiger Project at Chandrapur was 140 and 196 respectively. The students of each class are to be divided into groups of the same number of students. Each group can have a paid guide. What is the maximum number of students there can be in each group ? Why do you think each group should have the maximum possible number of students ?
- At the Rice Research Centre at Tumsar, there are 2610 kg of seeds of the basmati variety and 1980 kg of the Indrayani variety. If the maximum possible weight of seeds has to be filled to make bags of equal weight what should be the weight of each bag ? How many bags of each variety will there be ?



Let's learn.

Lowest Common Multiple : LCM

Write down the 3 times and 4 times tables. Note that a table has the multiples of a number arranged in serial order. Which is the smallest number divisible by both 3 and 4? We find the lowest common multiple or the LCM useful for certain purposes in daily life. Can you find the greatest common multiple of some given numbers? Think about it.

Rehana and Anne are making garlands of flowers. Both have to be given an equal number of flowers in their baskets.

Tai : Rehana, you make garlands of 6 flowers each. Anne, you make garlands of 8 flowers each. What is the minimum number of flowers I should put in your baskets?

Rehana : I want flowers in multiples of 6.

Anne : I want them in multiples of 8.

Multiples of 6 are numbers that are

divisible by 6 and they are 6, 12, 18, 24, 30, 36, 42, 48, 54, 60, 66, 72, 78, ...

Multiples of 8 are numbers that are divisible by 8 and they are 8, 16, 24, 32, 40, 48, 56, 64, 72, 80, 88, 96, 104, ...

The common multiples are 24, 48, 72, 96, ...

Rehana : Tai, if you give each of us 24, 48, 72 or 96 flowers, we will both be able to make the garlands as you want.

Anne : You will have to give us at least 24 flowers.

24 is the lowest common multiple or LCM of 6 and 8.

Example : Find the LCM of 13 and 6.

13 times table : 13, 26, 39, 52, 65, 78, 91, 104, 117, 130

6 times table : 6, 12, 18, 24, 30, 36, 42, 48, 54, 60

Here, we see no common multiples. So, let us extend the tables.

Further numbers divisible by 13 : 130, 143, 156, ...

Further numbers divisible by 6 : 60, 66, 72, 78, 84, ...

Looking at the lists of numbers divisible by 13 and 6, we see that 78 is the lowest common multiple. Therefore, the LCM of 13 and 6 is 78.



Now I know -

The LCM of two numbers cannot be bigger than their product.





Think about it.



Example : Pravin, Bageshri and Yash are cousins who live in the same house. Pravin is an Army Officer. Bageshri is studying in a Medical College in another city. Yash lives in a nearby town in a hostel. Pravin can come home every 120 days. Bageshri comes home every 45 days and Yash, every 30 days. All three of them left home at the same time on the 15th of June 2016. Their parents said, “We shall celebrate like a festival the day you all come home together.” Mother asked Yash, “What day will that be?”

Yash said, “The number of days after which we come back together must be divisible by 30, 45 and 120. That means we shall be back together on the 10th of June next year. That will certainly be a festival for us!”

How did Yash find the answer?



Now I know –

To find the LCM of the given numbers, we write down the multiples of each of the given numbers and find the lowest of their common multiples.

Practice Set 25

- Find out the LCM of the following numbers.
(1) 9, 15 (2) 2, 3, 5 (3) 12, 28 (4) 15, 20 (5) 8, 11
- Solve the following problems.
 - On the playground, if the children are made to stand for drill either 20 to a row or 25 to a row, all rows are complete and no child is left out. What is the lowest possible number of children in that school?
 - Veena has some beads. She wants to make necklaces with an equal number of beads in each. If she makes necklaces of 16 or 24 or 40 beads, there is no bead left over. What is the least number of beads with her?
 - An equal number of laddoos have been placed in 3 different boxes. The laddoos in the first box were distributed among 20 children equally, the laddoos in the second box among 24 children and those in the third box among 12 children. Not a single laddoo was left over. Then, what was the minimum number of laddoos in the three boxes altogether?
 - We observed the traffic lights at three different squares on the same big road. They turn green every 60 seconds, 120 seconds and 24 seconds. When the signals were switched on at 8 o'clock in the morning, all the lights were green. How long after that will all three signals turn green simultaneously again?
 - Given the fractions $\frac{13}{45}$ and $\frac{22}{75}$ write their equivalent fractions with same denominators and add the fractions.



A Maths Riddle!

We have four papers. On each of them there is a number on one side and some information on the other. The numbers on the papers are 7, 2, 15, 5. The information on the papers is given below in random order.

- | | |
|------------------------------|--------------------------------|
| (I) A number divisible by 7. | (II) A prime number |
| (III) An odd number | (IV) A number greater than 100 |

If the number on every paper is mismatched with the information on its other side, what is the number on the paper which says 'A number greater than 100'?



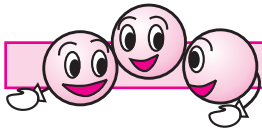

Let's discuss.

- Teacher** : Find two numbers and a mathematical operation to get the answer 15.
- Sharvari** : 5×3 gives 15 and 45 divided by 3 also gives 15.
- Shubhankar** : $17 - 2$ gives 15. And 5 added to 10 also gives 15.
- Teacher** : Very good! We see that the operations 5×3 and $17 - 2$ both give the same result. We write this as $5 \times 3 = 17 - 2$. In mathematics, the sign of equality ($=$) shows that the numbers on both its sides are equal. They may be the result of different operations on the left and right hand sides. Such an expression of equality is called an **equation**.
- Sharvari** : Can we also write the equation $17 - 2 = 5 \times 3$?
- Teacher** : Yes, that equation is right, too. If you write a new equation simply by exchanging the two sides of an equation, then the new equation is also correct, that is, balanced.



Let's learn.

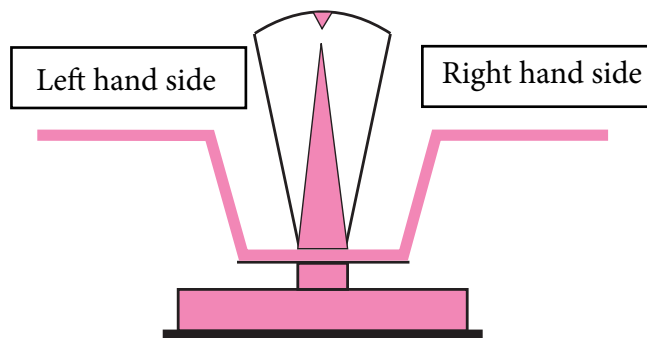

If there are equal weights in both pans of a weighing scale, then the scale is balanced.
Such a balanced scale is like an equation.

Practice Set 26

- * Different mathematical operations are given in the two rows below. Find out the number you get in each operation and make equations.

| | | | | |
|---------------|---------------|-----------|--------------|---------|
| $16 \div 2,$ | $5 \times 2,$ | $9 + 4,$ | $72 \div 3,$ | $4 + 5$ |
| $8 \times 3,$ | $19 - 10,$ | $10 - 2,$ | $37 - 27,$ | $6 + 7$ |



Let's learn.

The Solution of an Equation

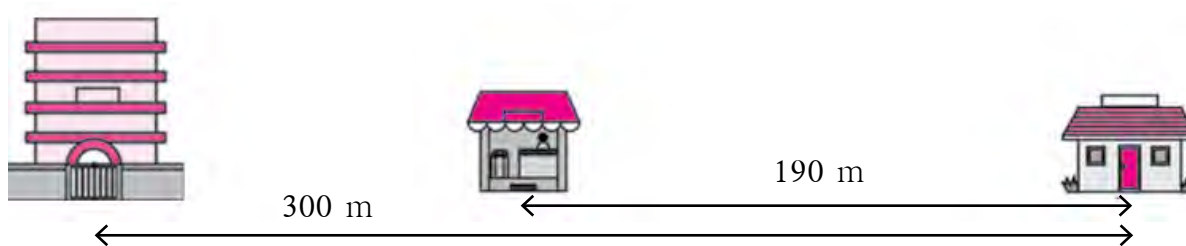

In the picture above, the distance between the house and the school is seen to be 300 m. On the same straight road, there is a shop between the school and the house. The distance between the shop and the house is 190 m. What is the distance between the school and the shop?

Use of a Letter for a Number

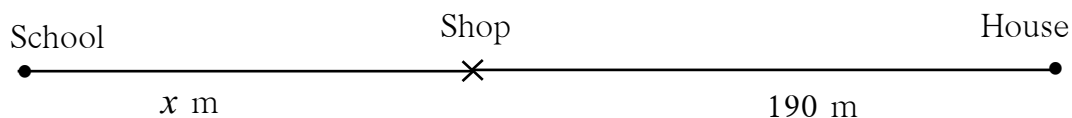

Teacher : See how the given information is shown in the picture above.

Sujata : Sir, why is the distance from the shop to the school shown as x ?

Teacher : Instead of writing the number, we suppose that the distance is x . That is the distance we have to find out. Till we do so, we write it as x .

Samir : Then the sum of x and 190 should be 300.

Teacher : That's right! Let's write this in the form of an equation. Remember that x is a number but we do not know its value as yet.

$$x + 190 = 300$$

What is the value of x here?

Shabana tried out various numbers for x .

First she supposed x was equal to 70. The left hand side became $70 + 190 = 260$. That was less than the right hand side. Then she took 150 for x and the left hand side became 340. This was greater than the right hand side. Finally, she chose 110 for the value of x . That made the left hand side the same as the right hand side and the equation was balanced. It meant that the value of x or the distance between the shop and the school was 110 metres.

In an equation, a letter is sometimes used in place of a number. A value for the letter has to be found that will make the equation balanced. Such a letter is called a 'variable'.

The value of the variable which balances or satisfies the equation is called the 'solution' to the equation. To solve an equation is to find the value of the variable in the equation or to find the solution to the equation.

In the example above, the solution to the equation ' $x + 190 = 300$ ' is 110.





Let's learn.

Solving an Equation

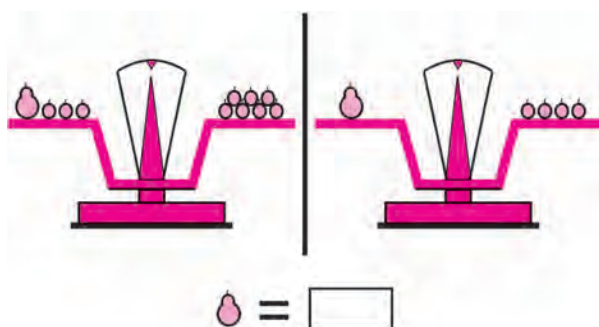

Teacher : How can we find the weight of a guava in terms of bors ?

John : If we remove 3 bors from each of the pans, they remain balanced, and then we can see that one guava weighs 4 bors.

Teacher : Excellent! You found the right operation. When solving an equation with one variable, we carry out the same operations on both sides of the equation to obtain simpler balanced equations, because, if the first equation is balanced then the new one obtained in this way is also balanced. The equations become simpler and simpler and finally we get the value of the variable, that is, the solution to the equation.

$$x + 3 = 7$$

$$\therefore x + 3 - 3 = 7 - 3 \quad \text{(Subtracting 3 from both sides)}$$

$$\therefore x + 0 = 4$$

$$\therefore x = 4$$

Let us take a second look at the previous equation.

$$x + 190 = 300$$

$$\therefore x + 190 - 190 = 300 - 190 \quad \text{(Subtracting 190 from both sides)}$$

$$\therefore x + 0 = 110$$

$$\therefore x = 110$$

While solving an equation, we can use this simple and unerring way rather than examining several random solutions.

Let us solve some examples using equations.

Example : Four years ago, Diljit was 8 years old. How old is he today?

Let us suppose he is a years old today.

Now, let's write the given information using a .

$$a - 4 = 8$$

$$\therefore a - 4 + 4 = 8 + 4 \quad \text{(Adding 4 to both sides)}$$

$$\therefore a + 0 = 12$$

$$\therefore a = 12$$

\therefore Diljit is 12 years old today.

Example : Jasmine has some money. Mother gave her 7 rupees. Jasmine now has 10 rupees. How much did she have to start with?

Let us suppose Jasmine had y rupees.

$$\therefore y + 7 = 10$$

$$\therefore y + 7 - 7 = 10 - 7 \quad \text{(Subtracting 7 from both sides)}$$

$$\therefore y + 0 = 3$$

$$\therefore y = 3$$

It means that Jasmine had 3 rupees to start with.

Example : There are some pedhas in a box. If some children are given 2 pedhas each, the pedhas would be enough for 20 children. How many pedhas are there in the box?



Let the total number of pedhas be p .

$$\frac{p}{2} = 20$$

$$\therefore \frac{p}{2} \times 2 = 20 \times 2 \quad \text{(Multiplying both sides by 2)}$$

$$p = 40$$

Therefore, there are 40 pedhas in the box.

Example : 5 chocolates cost 25 rupees.

How much does one cost?

If one chocolate costs k rupees,

$$5k = 25$$

$$\therefore \frac{5k}{5} = \frac{25}{5} \quad \text{(Dividing both sides by 5)}$$

$$\therefore 1k = 5$$

$$\therefore k = 5$$

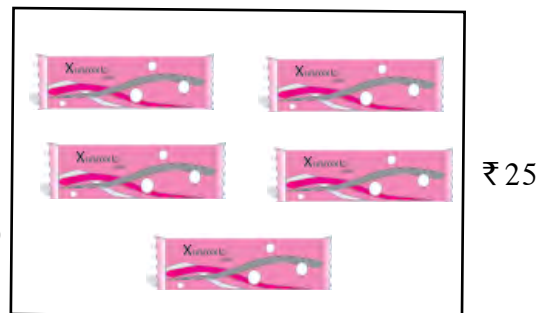

Therefore, one chocolate costs 5 rupees.

 **Now I know -**

If the same operation is carried out on both sides of an equation every time, the equation remains balanced. When any of the following operations are carried out on an equation, the equation remains balanced.

- Adding the same number to both the sides.
- Subtracting the same number from both the sides.
- Multiplying both the sides by the same number.
- Dividing both the sides by the same non-zero number.
- Exchanging the two sides.

1. Rewrite the following using a letter.
 - (1) The sum of a certain number and 3.
 - (2) The difference obtained by subtracting 11 from another number.
 - (3) The product of 15 and another number.
 - (4) Four times a number is 24.
2. Find out which operation must be done on both sides of these equations in order to solve them.
 - (1) $x + 9 = 11$ (2) $x - 4 = 9$ (3) $8x = 24$ (4) $\frac{x}{6} = 3$
3. Given below are some equations and the values of the variables. Are these values the solutions to those equations?

| No | Equation | Value of the variable | Solution (Yes/No) |
|----|--------------------|-----------------------|-------------------|
| 1 | $y - 3 = 11$ | $y = 3$ | No |
| 2 | $17 = n + 7$ | $n = 10$ | |
| 3 | $30 = 5x$ | $x = 6$ | |
| 4 | $\frac{m}{2} = 14$ | $m = 7$ | |

4. Solve the following equations.
 - (1) $y - 5 = 1$ (2) $8 = t + 5$ (3) $4x = 52$ (4) $19 = m - 4$
 - (5) $\frac{p}{4} = 9$ (6) $x + 10 = 5$ (7) $m - 5 = -12$ (8) $p + 4 = -1$
5. Write the given information as an equation and find its solution.
 - (1) Haraba owns some sheep. After selling 34 of them in the market, he still has 176 sheep. How many sheep did Haraba have at first?
 - (2) Sakshi prepared some jam at home and filled it in bottles. After giving away 7 of the bottles to her friends, she still has 12 for herself. How many bottles had she made in all? If she filled 250g of jam in each bottle, what was the total weight of the jam she made?
 - (3) Archana bought some kilograms of wheat. She requires 12kg per month and she got enough wheat milled for 3 months. After that, she had 14 kg left. How much wheat had Archana bought altogether?



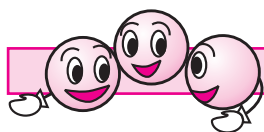

Let's discuss.

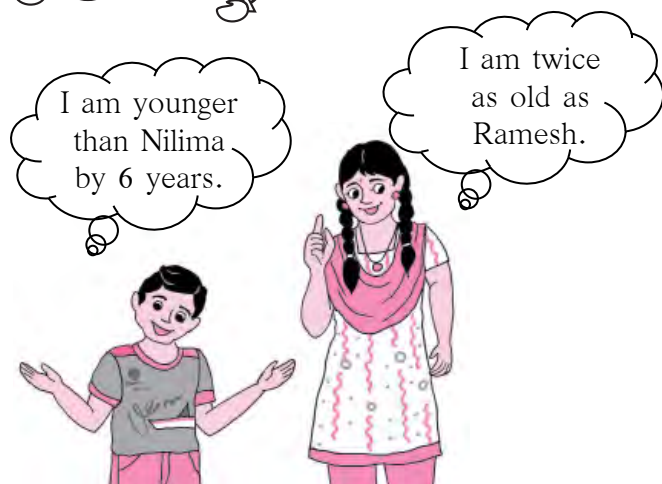

In the previous classes, we have learnt to compare two numbers. We shall now learn another way to do the same.

Let's say Nilima is 12 years old and Ramesh is 6. How to compare their ages?

Ramesh did so by finding out the difference.

Nilima did it by saying how many times she is as old as Ramesh.



Let's learn.

Nilima's age is twice as much as Ramesh's. We can give the same information by saying that Nilima's and Ramesh's ages are in the proportion **2:1**. It is read as '**Two is to one**'. In mathematics, the proportion of two numbers can also be expressed as their ratio. The proportion 2:1 is written as $\frac{2}{1}$ in the form of a ratio.

Examples of Proportion in Daily Life



Example : Jankamma's idlis and dosas are delicious. For idlis, she uses udad dal and rice in the proportion 1 cup dal to 2 cups of rice. But for dosas, the proportion is 1 cup dal to 3 cups of rice. That is, for idlis the proportion of dal and rice is 1:2 or the ratio is $\frac{1}{2}$ whereas for dosas, the proportion is 1:3 or the ratio is $\frac{1}{3}$.

Example : Margaret makes great biscuits. She uses 3 cups of wheat flour with 2 cups of sugar. It means that the proportion of sugar and flour in the biscuits is 2:3 or that the ratio is $\frac{2}{3}$.



Example : Flowers were distributed among the girls in equal proportions.

Fill in the empty boxes.

| | | | | |
|----------------|----|-------|-------|-------|
| Girls | 3 | 5 | | 1 |
| Flowers | 12 | | 32 | |



$$\frac{\text{Number of girls}}{\text{Number of flowers}} = \frac{3}{12} = \frac{1}{4}$$

It means that every girl got 4 flowers.

The proportion of girls and flowers is 'One is to every four'. It is written as 1:4 or their ratio is written as $\frac{1}{4}$.

Example : Every student finds the ratio of his or her own age to that of his/her grandmother's.

John's age is 10 years and his grandmother's 65. John said the ratio was $\frac{10}{65}$ for him. $\frac{10}{65} = \frac{10 \div 5}{65 \div 5} = \frac{2}{13}$ We can make use of equivalent fractions to write the ratio in the simplest form.

Example : Nikhil brought 12 guavas and 16 chikoos.

(1) Find the ratio of guavas to chikoos.

(2) Find the ratio of chikoos to guavas.

$$\frac{\text{Ratio of guavas to chikoos}}{\text{Number of guavas}} = \frac{12}{16} = \frac{12 \div 4}{16 \div 4} = \frac{3}{4}$$

\therefore Ratio of guavas to chikoos is $\frac{3}{4}$.

$$\frac{\text{Ratio of chikoos to guavas}}{\text{Number of chikoos}} = \frac{16}{12} = \frac{16 \div 4}{12 \div 4} = \frac{4}{3}$$

\therefore Ratio of chikoos to guavas is $\frac{4}{3}$.

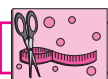

Try this.

In the figure, colour some boxes with any colour you like and leave some blank.

- (1) Count all the boxes and write the number.
- (2) Count the coloured ones and write the number.
- (3) Count the blank ones and write the number.
- (4) Find the ratio of the coloured boxes to the blank ones.
- (5) Find the ratio of the coloured boxes to the total boxes.
- (6) Find the ratio of the blank boxes to the total boxes.

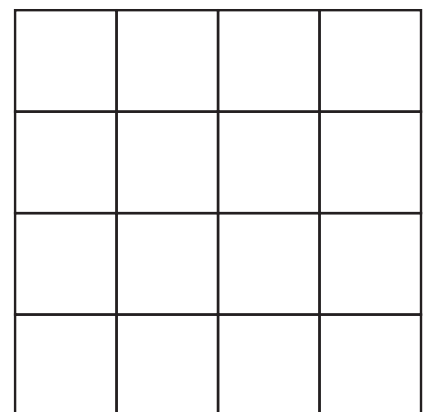



Let's learn.

Some Important Points about Ratio

Example : The weight of the large block of jaggery is 1 kg and a smaller lump weighs 200 g. Find the ratio of the weight of the lump of jaggery to that of the block.

$$\frac{\text{Weight of the lump}}{\text{Weight of the block}} = \frac{200}{1}$$



Is this right?

Is the weight of the lump 200 times that of the block?

What mistake have we made?

First we must measure both quantities in the same units.

It would be convenient to use grams here.

$$1\text{kg} = 1000 \text{ grams}$$

∴ The block weighs 1000 g and the lump, 200 g.

$$\frac{\text{Weight of the lump}}{\text{Weight of the block}} = \frac{200}{1000} = \frac{2 \times 100}{10 \times 100} = \frac{2}{10} = \frac{1 \times 2}{5 \times 2} = \frac{1}{5}$$

Thus, the ratio of the weight of the lump of jaggery to that of the block is $\frac{1}{5}$.



Now I know -

When finding the ratio of two quantities of the same kind, their measures must be in the same units.

A ratio can be used to write an equation. Then it is easier to solve the problem.

Example : A hostel is to be built for schoolgoing girls. Two toilets are to be built for every 15 girls. If 75 girls will be living in the hostel, how many toilets will be required in this proportion?

Let us consider the proportion or ratio of toilets and girls. Let us suppose x toilets will be needed for 75 girls. The ratio of the number of toilets to the

number of girls is $\frac{2}{15}$. Let us write this in two ways and form an equation.

$$\therefore \frac{x}{75} = \frac{2}{15}$$

$$\therefore \frac{x}{75} \times 75 = \frac{2}{15} \times 75 \quad (\text{Multiplying both sides by } 75)$$

$$\begin{aligned} \therefore x &= 2 \times 5 \\ &= 10 \end{aligned}$$

∴ 10 toilets will be required for 75 girls.



Practice Set 28

- In each example below, find the proportion of the first number to the second.
(1) 24, 56 (2) 63, 49 (3) 52, 65 (4) 84, 60 (5) 35, 65 (6) 121, 99
- Find the ratio of the first quantity to the second.
(1) 25 beads, 40 beads (2) 40 rupees, 120 rupees (3) 15 minutes, 1 hour
(4) 30 litres, 24 litres (5) 99 kg, 44000 grams (6) 1 litre, 250 ml
(7) 60 paise, 1 rupee (8) 750 grams, $\frac{1}{2}$ kg (9) 125 cm, 1 metre
- Reema has 24 notebooks and 18 books. Find the ratio of notebooks to books.
- 30 cricket players and 20 kho-kho players are training on a field. What is the ratio of cricket players to the total number of players?
- Snehal has a red ribbon that is 80 cm long and a blue ribbon, 2.20 m long. What is the ratio of the length of the red ribbon to that of the blue ribbon?
- Shubham's age today is 12 years and his father's is 42 years. Shubham's mother is younger than his father by 6 years. Find the following ratios.
 - Ratio of Shubham's age today to his mother's age today.
 - Ratio of Shubham's mother's age today to his father's age today
 - The ratio of Shubham's age to his mother's age when Shubham was 10 years old.



Let's learn.

The Unitary Method

Vijaya wanted to gift pens to seven of her friends on her birthday. When she went to a shop to buy them, the shopkeeper told her the rate for a dozen pens.

A dozen pens
cost rupees 84.



- Can you help Vijaya to find the cost of 7 pens?
- If you find the cost of one pen, you can also find the cost of 7, right?

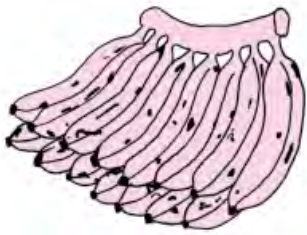

Example : A bunch of 15 bananas costs 45 rupees.
How much will 8 bananas cost?
Cost of 15 bananas, 45 rupees.
 \therefore Cost of 1 banana = $45 \div 15 = 3$ rupees
Therefore, the cost of 8 bananas is $8 \times 3 = 24$ rupees

Example : If a bunch of 10 flowers costs 25 rupees, how much will 4 flowers cost?

Cost of 10 flowers, 25 rupees.
 \therefore Cost of 1 flower = $\frac{25}{10}$ rupees
Therefore, cost of 4 flowers = $\frac{25}{10} \times 4 = 10$ rupees.



Now I know -

Find the cost of one article from that of many, by division.
Then find the cost of many articles from that of one, by multiplication.
This method of solving a problem is called the unitary method.

Practice Set 29

* Solve the following.

- (1) If 20 metres of cloth cost ₹3600, find the cost of 16 m of cloth.
- (2) Find the cost of 8 kg of rice, if the cost of 10 kg is ₹325.
- (3) If 14 chairs cost ₹5992, how much will have to be paid for 12 chairs?
- (4) The weight of 30 boxes is 6 kg. What is the weight of 1080 such boxes?
- (5) A car travelling at a uniform speed covers a distance of 165 km in 3 hours. At that same speed, (a) How long will it take to cover a distance of 330 km?
(b) How far will it travel in 8 hours?
- (6) A tractor uses up 12 litres of diesel while ploughing 3 acres of land. How much diesel will be needed to plough 19 acres of land?
- (7) At a sugar factory, 5376 kg of sugar can be obtained from 48 tonnes of sugarcane. If Savitai has grown 50 tonnes of sugarcane, how much sugar will it yield?
- (8) In an orchard, there are 128 mango trees in 8 rows. If all the rows have an equal number of trees, how many trees would there be in 13 rows?
- (9) A pond in a field holds 120000 litres of water. It costs 18000 rupees to make such a pond. How many ponds will be required to store 480000 litres of water, and what would be the expense?



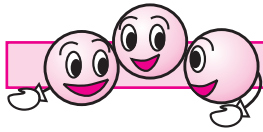

Let's discuss.

Use water carefully.

Water in the dam 58% of the capacity

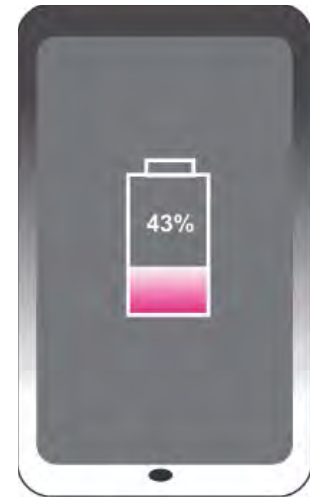
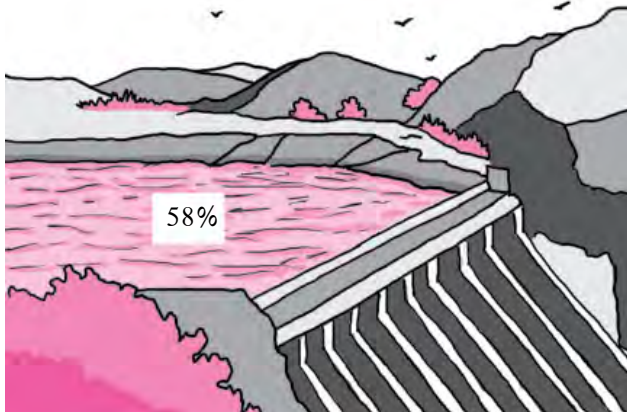

Raju : Dada, I can see this sign % after 58 in the picture above. And it's there also after 43 in the other picture. What does it show?

Dada : That is the sign for percentage. The word cent means hundred. We read 58% as '58 percent'.

Raju : Then, what does percentage mean?

Dada : In the first picture, there is 58% water in the dam. It means that if the dam holds 100 units of water when full, then right now it is holding 58 of the same units of water. If the mobile phone has 100 units of charge when it is fully charged, then at this moment 43 units of charge are still left. A percentage is a comparison made with a total which is taken to be 100 parts.

Raju : If there is 50% water in the dam, can we say that the dam is half full?

Dada : Yes, 50% is 50 parts of water out of 100, and half of 100 is 50.

58% is 58 units out of 100 units. We can write this as the fraction $\frac{58}{100}$.

It means that $\frac{58}{100}$ parts out of the full capacity of the dam are filled with water.

(1) Percentage in the Form of a Fraction

50% means 50 parts of a total of 100. So, 50 out of 100 or $\frac{50}{100} = \frac{1}{2}$ part.

In other words, 50% is half of the whole.

25% means 25 parts out of 100. And $\frac{25}{100} = \frac{1}{4}$ part of the whole (or total).

35% means 35 parts out of 100. And $\frac{35}{100} = \frac{7}{20}$ part of the whole.

(2) A Fraction in the Form of a Percentage

$$\frac{3}{4} = \frac{3 \times 25}{4 \times 25} = \frac{75}{100} \quad \frac{3}{4} \text{ part of the total is } \frac{75}{100} \text{ or } 75\%.$$

$$\frac{2}{5} = \frac{2 \times 20}{5 \times 20} = \frac{40}{100} \quad \frac{2}{5} \text{ part of the total is } \frac{40}{100} \text{ or } 40\%.$$



Now I know -

Equivalent fractions can be used to make the denominator 100.

Example : Last year Giripremi group planted 75 trees. Of these, 48 trees flourished. The Karmavir group planted 50 trees, of which, 35 flourished. Which group was more successful in conserving the trees they had planted?

The number of trees each group started with is different. Hence, we have to compare the surviving trees in each group to the number of trees planted by them. For this comparison, it would be useful to find out for each group, the percentage of their trees that survived. To do that, let us find the ratio of the number of surviving trees to the total trees planted.

Suppose the surviving trees of the the Giripremi group are A%.

Suppose the surviving trees of the the Karmavir group are B%.

The Giripremi's ratio of the surviving trees to planted trees is $\frac{A}{100}$ and also $\frac{48}{75}$. Therefore, $\frac{A}{100} = \frac{48}{75}$. In the same way, we can also find the ratio of surviving trees to planted trees for the Karmavir group.

Let us write the same ratio in two forms, obtain equations and solve them.

$$\begin{array}{ccc} \frac{A}{100} = \frac{48}{75} & \dots & \frac{B}{100} = \frac{35}{50} \\ \frac{A}{100} \times 100 = \frac{48}{75} \times 100 & \dots & \frac{B}{100} \times 100 = \frac{35}{50} \times 100 \\ A = 64 & \dots & B = 70 \end{array}$$

\therefore The Karmavir group was more successful in conserving the trees they had planted.

Example : In Khatav taluka, it was decided to make 200 ponds in Warudgaon and 300 ponds in Jakhangaon. Of these, 120 ponds in Warudgaon were completed at the end of May, while in Jakhangaon work was complete on 165 ponds. In which village was a greater proportion of the work completed?

To find the answer, we shall find the percentage of work completed in each village and then make a comparison.

Let the number of ponds completed in Warudgaon be A% and in Jakhangaon, B%. We shall find the ratio of the number of ponds completed to the number of ponds planned in each case. We then write those ratios in two forms, obtain equations and solve them.

$$\frac{A}{100} = \frac{120}{200}$$

$$\frac{A}{100} \times 100 = \frac{120}{200} \times 100$$

$$A = 60$$

$$\frac{B}{100} = \frac{165}{300}$$

$$\frac{B}{100} \times 100 = \frac{165}{300} \times 100$$

$$B = 55$$

∴ A greater proportion of the work was completed in Warudgaon.

Example : For summative evaluation in a certain school, 720 of the 1200 children were awarded A grade in Maths. What is the percentage of students getting A grade? Suppose the students getting A grade are A%.

Let us write in two forms, the ratio of the number of students getting A grade to the total number of students, obtain an equation and solve it.

$$\frac{A}{100} = \frac{720}{1200}$$

$$\therefore \frac{A}{100} \times 100 = \frac{720}{1200} \times 100$$

$$\therefore A = 60$$

$$\therefore 60\% \text{ students got A grade.}$$

Example : A certain Organization adopted 18% of the 400 schools in a district. How many schools did it adopt ?

Let us write in two forms, the ratio of the number of schools adopted to the total number of schools in the district, obtain an equation and solve it.

Here, 18% means 18 schools adopted out of a total of 100.

Total number of schools is 400. Suppose the number of schools adopted is A.

$$\frac{A}{400} = \frac{18}{100}$$

$$\therefore \frac{A}{400} \times 400 = \frac{18}{100} \times 400$$

$$\therefore A = 72$$

$$\therefore \text{The number of schools adopted is 72.}$$

Practice Set 30

* Solve the following.

- (1) Shabana scored 736 marks out of 800 in her exams. What was the percentage she scored?
- (2) There are 500 students in the school in Dahihanda village. If 350 of them can swim, what percent of them can swim and what percent cannot?
- (3) If Prakash sowed jowar on 75% of the 19500 sq m of his land, on how many sq m did he actually plant jowar?
- (4) Soham received 40 messages on his birthday. Of these, 90% were birthday greetings. How many other messages did he get besides the greetings?
- (5) Of the 5675 people in a village 5448 are literate. What is the percentage of literacy in the village?
- (6) In the elections, 1080 of the 1200 women in Jambhulgaon cast their vote, while 1360 of the 1700 in Wadgaon cast theirs. In which village did a greater proportion of women cast their votes?



Maths is fun!

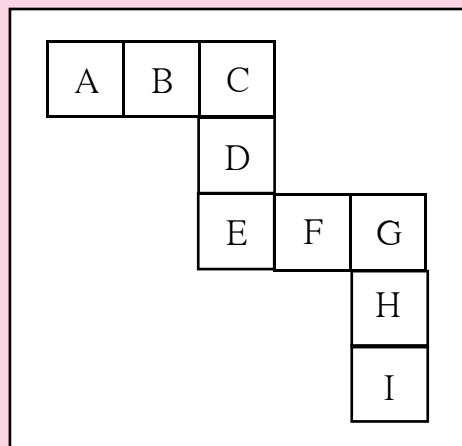

There are 9 squares in the figure above. The letters A B C D E F G H I are written in the squares. Give each of the letters a unique number from 1 to 9 so that every letter has a different number.

Besides, $A + B + C = C + D + E = E + F + G = G + H + I$ should also be true.



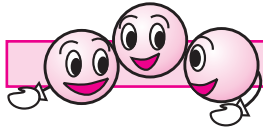

Let's discuss.



Details of Pranav's shopping for his stall :

| | |
|-----------------|------|
| Vegetables - | ₹ 70 |
| Butter - | ₹ 25 |
| Bread - | ₹ 45 |
| Masala - | ₹ 14 |
| Miscellaneous - | ₹ 20 |

Total -----

The amount Pranav gained through his sales : ₹ 160



How much did Pranav spend in all?
Why is he so disappointed?

Details of Sarita's shopping for her stall :

| | |
|-----------------|------|
| Plates - | ₹ 20 |
| Spoons - | ₹ 10 |
| Chutney - | ₹ 30 |
| Puffed rice - | ₹ 50 |
| Onions - | ₹ 20 |
| Miscellaneous - | ₹ 60 |

Total -----

Amount Sarita gained by selling :
₹ 230



How much did Sarita spend on her bhel?
Why does Sarita look so happy?

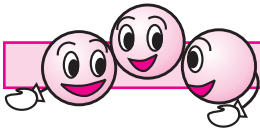

Let's discuss.

If Sarita had bought twice as much, would she have gained twice as much?

What should Pranav do the next time he sets up a stall to sell more pav bhaji and make more gains?



Let's learn.

Profit and Loss

People do various kinds of jobs to earn money. Shopkeepers sell articles that people need. They buy things from wholesale traders in large quantities at lower rates. It costs less than the printed price. When they sell things in retail, i.e., in smaller quantities, they charge a greater amount. If the selling price is more than the amount paid for it, there is a gain. It is called a **profit**. Sometimes, an article is sold for less than the amount paid for it while buying. The damage, in that case, is called a **loss**.



Now I know -

If the selling price is less than the cost price, there is a loss.

$$\text{Loss} = \text{Cost price} - \text{Selling price}$$

If the selling price is more than the cost price, there is a profit.

$$\text{Profit} = \text{Selling price} - \text{Cost price}$$

Example : Hamidbhai bought bananas worth 2000 rupees and sold them all for 1890 rupees. Did he make a profit or a loss? How much was it?

He bought bananas for ₹2000.

Hence,

$$\text{Cost price} = ₹2000$$

$$\text{Selling price} = ₹1890$$

Cost price is greater than selling price. Therefore, Hamidbhai suffered a loss.

$$\begin{aligned} \text{Loss} &= \text{Cost price} - \text{Selling price} \\ &= 2000 - 1890 \\ &= ₹110 \end{aligned}$$

∴ Hamidbhai suffered a loss of ₹110 in this transaction.

Example : Harbhajan Singh bought 500 kg of rice for 22000 rupees and sold it all at the rate of ₹48 per kg. How much profit did he make?

The cost price of 500 kg rice is ₹22000.

$$\begin{aligned} \text{Selling price of 500 kg of rice is} \\ &= 500 \times 48 = ₹24000 \end{aligned}$$

Selling price is greater than cost price.

Therefore, there is a profit.

$$\begin{aligned} \text{Profit} &= \text{Selling price} - \text{Cost price} \\ &= 24000 - 22000 \\ &= ₹2000 \end{aligned}$$

∴ In this transaction, Harbhajan Singh made a profit of ₹2000.

Practice Set 31

1. The cost price and selling price are given in the following table. Find out whether there was a profit or a loss and how much it was.

| Ex. | Cost price (in ₹) | Selling price (in ₹) | Profit or Loss | How much? |
|-----|-------------------|----------------------|----------------|-----------|
| 1. | 4500 | 5000 | | |
| 2. | 4100 | 4090 | | |
| 3. | 700 | 799 | | |
| 4. | 1000 | 920 | | |

2. A shopkeeper bought a bicycle for ₹3000 and sold the same for ₹3400. How much was his profit?
3. Sunandabai bought milk for ₹475. She converted it into yoghurt and sold it for ₹700. How much profit did she make?
4. The Jijamata Women's Saving Group bought raw materials worth ₹15000 for making chakalis. They sold the chakalis for 22050 rupees. How much profit did the WSG make?
5. Pramod bought 100 bunches of methi greens for ₹400. In a sudden downpour, 30 of the bunches on his handcart got spoilt. He sold the rest at the rate of ₹5 each. Did he make a profit or a loss? How much?
6. Sharad bought one quintal of onions for ₹2000. Later he sold them all at the rate of ₹18 per kg. Did he make a profit or incur a loss? How much was it?
7. Kantabai bought 25 saris from a wholesale merchant for ₹10000 and sold them all at ₹460 each. How much profit did Kantabai get in this transaction?

Total Cost price and Profit or Loss



At Diwali, in a certain school, they undertook a 'Design a Diya' project. They bought 1000 diyas for ₹1000 and some paint for ₹200. To bring the diyas to the school, they spent ₹100 on transport. They sold the painted lamps at ₹2 each. Did they make a profit or incur a loss?



Cost price of diyas ₹1000
and selling price ₹2000.
So, profit was ₹1000.

- Is Anju right?
- What about the money spent on paints and transport?
- How much money was actually spent before the diyas could be sold?
- How much actual profit was made in this project of colouring diyas and selling them? Besides purchases, money has to be spent on things like transport, portorage, octroi, etc.
When this expenditure is added to the basic purchase, we get the total cost price.



Let's learn.

In trading, all expenses incurred on an article before it can be sold have to be added to the cost price of the article. That is called the total cost price of the article.



Think about it.

A farmer sells what he grows in his fields. How is the total cost price calculated? What does a farmer spend on his produce before he can sell it? What are the other expenses besides seeds, fertilizers and transport?

Example : Sambhajirao bought a machine from a factory for ₹80000. He paid the octroi tax of ₹1600 and spent ₹800 on transport besides ₹300 on portorage. He sold the machine for one lakh rupees. How much was his profit?

$$\begin{aligned} &\text{Total expenses while buying the machine} \\ &= \text{Cost of machine} + \text{Octroi} + \text{Transport} + \text{Portorage} \\ &= 80000 + 1600 + 800 + 300 \\ &= ₹82700 \end{aligned}$$

That is, total cost price is ₹82700.

$$\begin{aligned} \text{Profit} &= \text{Selling price} - \text{Total cost price} \\ &= 100000 - 82700 \\ &= ₹17300 \end{aligned}$$

Sambhajirao made a profit of ₹17300 in this transaction.

Example : Javedbhai bought 35 electric mixers for ₹4300 each. To transport them to the shop, he spent ₹2100. If he expects to make a profit of ₹21000, at what price should he sell each mixer?

Cost price of one mixer ₹4300.

Hence cost price of 35 mixers = $4300 \times 35 = ₹150500$

$$\begin{aligned} \text{Total cost price} &= \text{cost of mixers} + \text{cost of transport} \\ &= 150500 + 2100 \\ &= ₹ 152600 \end{aligned}$$

Javedbhai wants a profit of 21000 rupees.

∴ Hence, amount expected on selling

$$\begin{aligned} &= 152600 + 21000 \\ &= ₹ 173600 \end{aligned}$$

Selling price of 35 mixers = ₹ 173600

∴ Selling price of one mixer = $173600 \div 35$
= ₹ 4960

Javedbhai should sell every mixer for ₹ 4960.

$$\begin{array}{r} 4960 \\ 35 \overline{) 173600} \\ \underline{- 140} \\ 0336 \\ \underline{- 315} \\ 00210 \\ \underline{- 210} \\ 00000 \\ \underline{- 0} \\ 0 \end{array}$$

Practice Set 32

- From a wholesaler, Santosh bought 400 eggs for ₹ 1500 and spent ₹ 300 on transport. 50 eggs fell down and broke. He sold the rest at ₹ 5 each. Did he make a profit or a loss? How much?
- Abraham bought goods worth ₹ 50000 and spent ₹ 7000 on transport and octroi. If he sold the goods for ₹ 65000, did he make a profit or a loss? How much?
- Ajit Kaur bought a 50 kg sack of sugar for ₹ 1750, but as sugar prices fell she had to sell it at ₹ 32 per kg. How much loss did she incur?
- Kusumtai bought 80 cookers at ₹ 700 each. Transport cost her ₹ 1280. If she wants a profit of ₹ 18000, what should be the selling price per cooker?
- Indrajit bought 10 refrigerators at ₹ 12000 each and spent ₹ 5000 on transport. For how much should he sell each refrigerator in order to make a profit of ₹ 20000?
- Lalitabai sowed seeds worth ₹ 13700 in her field. She had to spend ₹ 5300 on fertilizers and spraying pesticides and ₹ 7160 on labour. If, on selling her produce, she earned ₹ 35400 what was her profit or her loss?



Let's learn.

Profit Percent, Loss Percent

When determining the percentage of profit or loss, it is compared with the cost price. When we say that the profit or the loss was 10%, we mean that the profit or the loss is 10 rupees if the total cost price is taken to be 100 rupees.

Example : Abbas bought vegetables worth ₹400 and sold them for ₹650. Balbir bought fruits for ₹300 and sold them for ₹500. Whose transactions were more profitable?

Abbas made a profit of ₹250 and Balbir's profit was ₹200. However, the cost price for each of them was different. To compare, we shall have to find out the percentages of the profits.

Let us suppose Abbas made A% and Balbir made B% profit.

Let us find the ratios of profit to cost price, express those ratios in two forms, obtain equations and solve them.

$$\frac{A}{100} = \frac{250}{400}$$

$$\frac{A}{100} \times 100 = \frac{250 \times 100}{400}$$

$$A = \frac{250}{4} = \frac{125}{2} = 62\frac{1}{2}$$

$$\frac{B}{100} = \frac{200}{300}$$

$$\frac{B}{100} \times 100 = \frac{200 \times 100}{300}$$

$$B = \frac{200}{3} = 66\frac{2}{3}$$

∴ Balbir's transactions were more profitable.

Example : Seema bought vegetables for ₹800 and, paying ₹40 for transport, brought them to her shop. On selling the vegetables, she got ₹966.

Did she make a profit or a loss? What was the percentage?

Let us first find out total cost price.

$$\begin{aligned} \text{Total cost price} &= \text{cost of vegetables} + \text{transport charges} \\ &= 800 + 40 \\ &= ₹ 840 \end{aligned}$$

$$\begin{aligned} \text{Profit} &= \text{Selling price} - \text{total cost price} \\ &= 966 - 840 \\ &= ₹ 126 \end{aligned}$$

Let us suppose the percent profit was y. We shall express the ratio of profit to total cost price in two forms, obtain an equation and solve it.

$$\frac{Y}{100} = \frac{126}{840}$$

$$\frac{Y}{100} \times 100 = \frac{126}{840} \times \frac{100}{1}$$

$$y = 15$$

∴ Seema made a profit of 15%.

Practice Set 33

1. Maganlal bought trousers for ₹400 and a shirt for ₹200 and sold them for ₹448 and ₹250 respectively. Which of these transactions was more profitable?
2. Ramrao bought a cupboard for ₹4500 and sold it for ₹4950. Shamrao bought a sewing machine for ₹3500 and sold it for ₹3920. Whose transaction was more profitable?

3. Hanif bought one box of 50 apples for ₹400. He sold all the apples at the rate of ₹10 each. Was there a profit or a loss? What was its percentage?



Let's learn.

Using given information to frame and solve word problems based on percent profit or loss.

Information : Cost price ₹23500,
transport ₹1200, tax ₹300,
selling price ₹24250.

Problem

- Joseph bought a machine for ₹ 23500. He paid ₹ 1200 for transport and ₹ 300 as tax. If he sold it to a customer for ₹ 24250, what was his percent profit or loss?

$$\begin{aligned} \text{Total cost price of machine} \\ &= 23500 + 1200 + 300 \\ &= ₹25000 \end{aligned}$$

$$\text{Selling price} = ₹24250$$

Cost price greater than selling price. Therefore, loss.

$$\begin{aligned} \text{Loss} &= \text{Cost price} - \text{Selling price} \\ &= 25000 - 24250 \\ &= 750 \end{aligned}$$

Joseph suffered a loss of ₹750.

Supposing loss was N%, write the ratio of loss to total cost price in two forms, obtain an equation and solve it.

$$\frac{N}{100} = \frac{750}{25000}$$

$$\therefore \frac{N}{100} \times 100 = \frac{750}{25000} \times 100$$

$$\therefore N = 3$$

$$\therefore \text{Loss} = 3\%$$

Information : ₹700, 18 articles, ₹18900

Problem

- Saritaben bought 18 chairs each at ₹700 and sold them all for ₹18900. What was the percentage of her profit or loss?

Cost price of one chair ₹700.

$$\begin{aligned} \therefore \text{Cost price of 18 chairs} \\ &= 700 \times 18 = ₹12600 \end{aligned}$$

Total selling price of all chairs, ₹18900

Selling price more than cost price.

Therefore, profit.

$$\begin{aligned} \text{Profit} &= \text{Selling price} - \text{Cost price} \\ &= 18900 - 12600 \\ &= 6300 \end{aligned}$$

Saritaben made a profit of ₹6300.

Supposing profit was N%. We write the ratio of profit to cost price in two forms, obtain an equation and solve it.

$$\frac{N}{100} = \frac{6300}{12600}$$

$$\therefore \frac{N}{100} \times 100 = \frac{6300}{12600} \times 100$$

$$\therefore N = \frac{63 \times 100}{126}$$

$$\therefore N = 50$$

∴ Profit was 50%.

Practice Set 34

* Using the figures given below, frame problems based on profit percent or loss percent and solve the problems.

- | | |
|--|--|
| <ol style="list-style-type: none"> 1. Cost price ₹1600, selling price ₹2800. 2. Cost price ₹2000, selling price ₹1900. 3. Cost price of 8 articles is ₹1200 each, selling price ₹1400 each. 4. Cost price of 50kg grain ₹2000, Selling price ₹43 per kg. | <ol style="list-style-type: none"> 5. Cost price ₹8600, transport charges ₹250, porterage ₹150, selling price ₹10000 6. Seeds worth ₹20500, labour ₹9700, chemicals and fertilizers ₹5600, selling price ₹28640. |
|--|--|

Project :

- Relate instances of profit and loss that you have experienced. Express them as problems and solve the problems.
- Organise a fair. Gain the experience of selling things/trading. What was the expenditure on preparing or obtaining the goods to be sold? How much were the sales worth? Write a composition about it or enact this entire transaction.

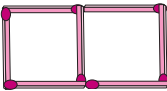
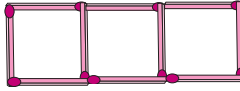

Maths is fun!

| | | | | |
|--------------------------|---|---|--|--|
| Number of squares |  |  |  | |
| Number of sticks | 4 | 7 | 10 | |

Arpita used 4 matchsticks to make a square. Then she took 3 more sticks and arranged them to make 2 squares. Another 3 sticks helped her to make 3 squares. How many sticks are needed to make 7 such squares in the same way? How many sticks are needed to make 50 squares?





Let's recall.



What does the picture above show? Find out about the nature of work done in this office. Make a note of your observations.



Let's learn.

A Bank

A bank is a government recognized organisation that carries out transactions of money. It is a **financial organisation**. Finance relates to money.

We need to be prudent in spending the money we earn. We save money for use in the future. Our savings are meant to meet expenses on education, building a house, medical treatment, on our occupation such as for using improved

methods of agriculture, etc. Small savings made regularly accumulate over a period to become a large amount and prove useful in the future. An amount kept in a bank remains safe and also grows over the years.

Financial Transactions

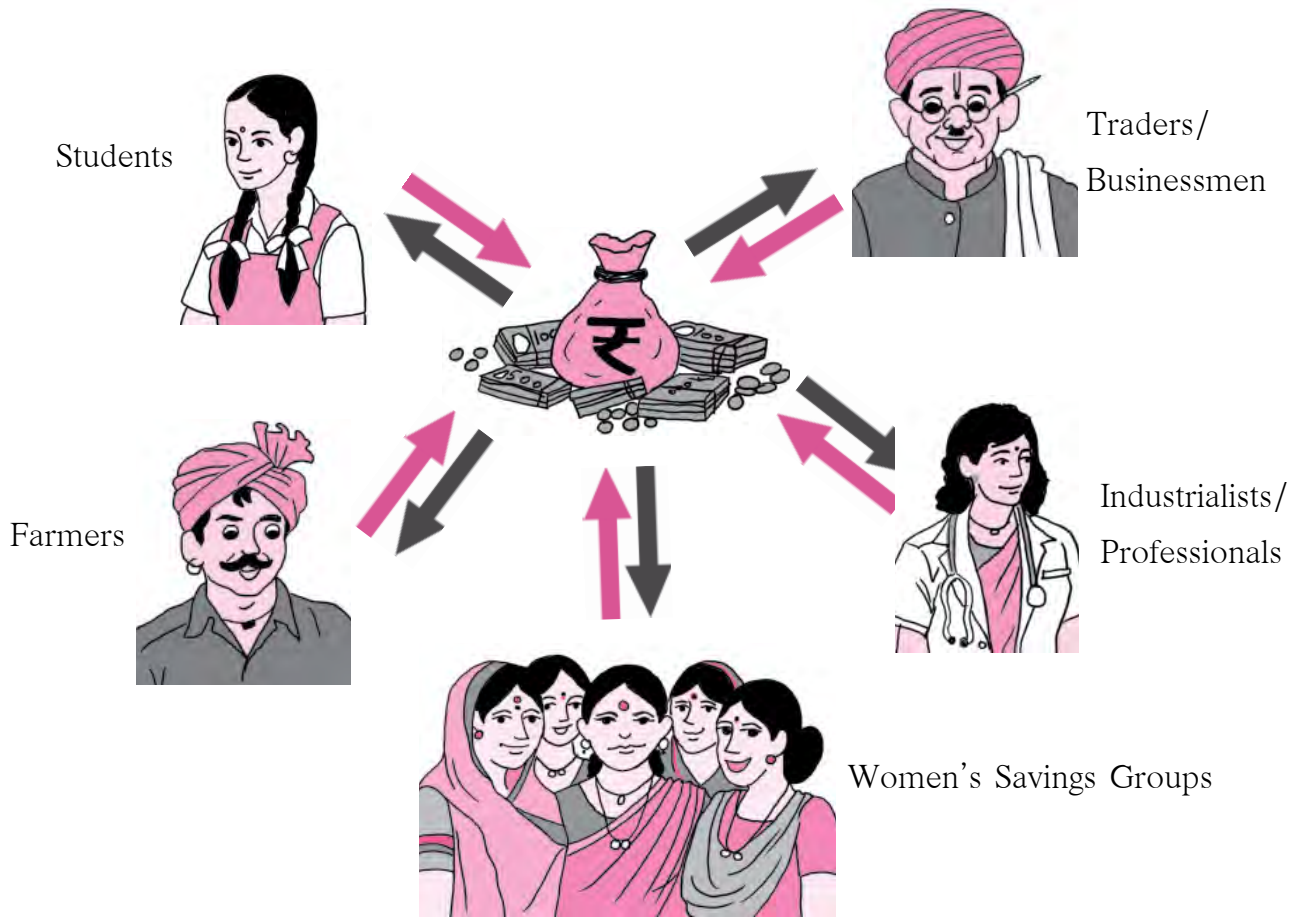

- In the above picture, who are the people shown to be using bank services?
- What does the symbol on the bag in the centre stand for?
- What do the arrows in the above picture tell you?

Project Work

- Teachers should organise a visit to a bank. Encourage the children to obtain some preliminary information about banks. Help them to fill some bank forms and slips for withdrawals and deposits.
- If there is no bank nearby, teachers could obtain specimen forms and get the children to fill them in class.
- Give a demonstration of banking transactions by setting up a mock bank in the school.
- Invite participation of parents who work in banks or other bank employees to give the children more detailed information about banking.





Let's learn.

Bank Accounts

To use banking services one has to open an account in a bank. We need the following documents or papers to open a new bank account.

- (1) Proof of residence : Ration card, electricity bill, telephone bill, domicile certificate, identity card, etc.
- (2) Proof of identity : Aadhaar card, voter's identity card, PAN card, passport or any other proof suggested by the bank, besides a reference from another customer who is an account holder.

A savings account is meant to induce a habit of saving money. An account holder can deposit money in the savings account as and when money is available. He/She may also withdraw/take out some money from that account occasionally if needed.

Banks give an interest of 4% to 6% on the money in the savings account. The customer gets facilities like a pass-book, cheque book, ATM card, mobile banking, sms banking, Internet banking, etc. to operate the account.

We have to fill in certain printed slips to deposit money in an account or to withdraw it. Every bank has its own different forms, but the information to be given in it is the same.

There is another kind of bank account called a current account. Money can be withdrawn from it any number of times,

but one does not get any interest on the amount in this account.

To get more interest, we have to keep a fixed amount in a bank for a longer period of time. We can avail of facilities like the Fixed Deposit (FD) or Recurring Deposit (RD) schemes for that purpose.

Calculation of Interest

Account holders of a bank are paid some amounts for keeping their money in the bank. On the other hand, people who borrow from a bank are charged an amount for the use of the money loaned to them. Such amounts are called **interest**. The money deposited in the bank or the money lent by a bank to a borrower is called the **principal**.

When calculating interest on a deposit or a loan, the rate of interest is given for every 100 rupees. That rate of interest is for a given period of time. A rate of interest 'per cent per annum', written as **p.c.p.a.**, gives the amount of interest due on every hundred rupees for a **period** of one year, that is, annually.

Simple Interest

In this class, we shall learn only about the interest charged for one year. This is simple interest. The interest charged for longer periods of time can often be quite complicated. That rate is different from simple interest.

Example 1 : Vinita deposited ₹15000 in a bank for one year at an interest rate of 7 p.c. p.a. How much interest will she get at the end of the year?

In this example, the principal is ₹15000, period is 1 year, and rate of interest is 7 p.c.p.a. If principal increases, interest increases. That is, interest increases in proportion to the principal.

Let us suppose that the interest on the principal of ₹15000 is x .

On principal ₹100, the interest is ₹7.

We shall take the ratio of interest to principal, write it in two forms and obtain an equation.

$$\frac{x}{15000} = \frac{7}{100}$$
$$\frac{x}{15000} \times 15000 = \frac{7}{100} \times 15000 \quad (\text{Multiplying both sides by } 15000)$$

$$x = 1050$$

Vinita will get an interest of ₹1050.

Example 2 : Vilasrao borrowed ₹20000 from a bank at a rate of 8 p.c.p.a. What is the amount he will return to the bank at the end of the year?

In this example, the principal is ₹20000. Rate is 8 p.c.p.a., that is, ₹8 is the interest on principal ₹100 for 1 year.

Interest increases in proportion to the principal, that is, ratio of interest to principal remains constant. Let us write the ratio of interest to principal in two ways and obtain an equation.

Let interest on principal 20000 rupees be x rupees.

Interest on principal 100 rupees is 8 rupees.

$$\frac{x}{20000} = \frac{8}{100}$$
$$\frac{x}{20000} \times 20000 = \frac{8}{100} \times 20000 \quad (\text{Multiplying both sides by } 20000)$$

$$x = 1600$$

Amount to be returned to the bank = principal + interest = 20000 + 1600 = ₹21600

Practice Set 35

- (1) At a rate of 10 p.c.p.a., what would be the interest for one year on ₹6000?
- (2) Mahesh deposited ₹8650 in a bank at a rate of 6 p.c.p.a. How much money will he get at the end of the year in all?
- (3) Ahmed Chacha borrowed ₹25000 at 12 p.c.p.a. for a year. What amount will he have to return to the bank at the end of the year?
- (4) Kisanrao wanted to make a pond in his field. He borrowed ₹35250 from a bank at an interest rate of 6 p.c.p.a. How much interest will he have to pay to the bank at the end of the year?

SSS

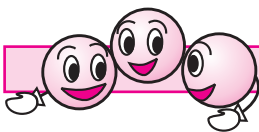

Let's discuss.

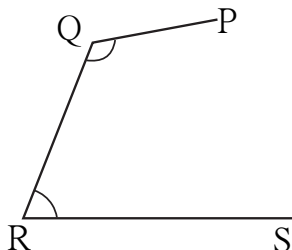
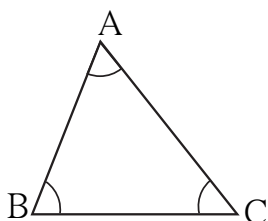

In the figure alongside, some points and some line segments joining them have been drawn.

Which of these figures is a triangle? Which figure is not a triangle? Why not?

$\triangle ABC$ has three sides. Line segment AB is one side. Write the names of the other two sides. $\triangle ABC$ has three angles. $\angle ABC$ is one of them. Write the names of the other angles.

Points A, B and C are called the vertices of the triangle.



Let's learn.

A triangle is a closed figure made by joining three non-collinear points by line segments.

The vertices, sides and angles of a triangle are called the parts of the triangle.

Types of Triangles – Based on Sides

Measure the sides of the following triangles in centimetres, using a divider and ruler. Enter the lengths in the table below. What do you observe?

'Length of line segment AB' is written as $l(AB)$.

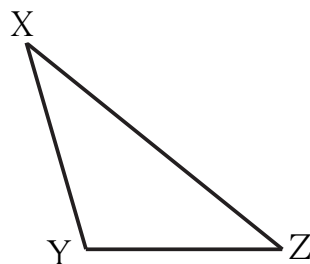
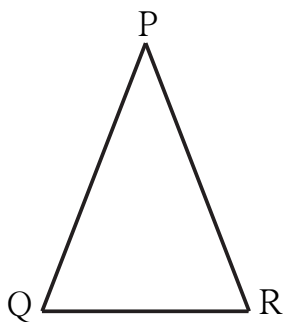
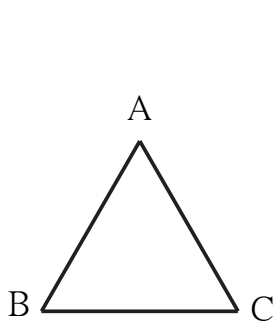

| In $\triangle ABC$ | In $\triangle PQR$ | In $\triangle XYZ$ |
|--------------------|--------------------|--------------------|
| $l(AB) = \dots$ cm | $l(QR) = \dots$ cm | $l(XY) = \dots$ cm |
| $l(BC) = \dots$ cm | $l(PQ) = \dots$ cm | $l(YZ) = \dots$ cm |
| $l(AC) = \dots$ cm | $l(PR) = \dots$ cm | $l(XZ) = \dots$ cm |

In the table above, the lengths of all sides of $\triangle ABC$ are equal. Therefore, this triangle is an equilateral triangle. 'Lateral' refers to the sides of a figure.

A triangle with all three sides equal is called an equilateral triangle.

In $\triangle PQR$, the length of the two sides PQ and PR are equal. $\triangle PQR$ is called an isosceles triangle.

A triangle with two equal sides is called an isosceles triangle.

The lengths of the sides of $\triangle XYZ$ are all different. Such a triangle is called a scalene triangle.

A triangle with no two sides equal is called a scalene triangle.

Types of Triangles – Based on Angles

Measure all the angles of the triangles given below. Enter them in the following table.

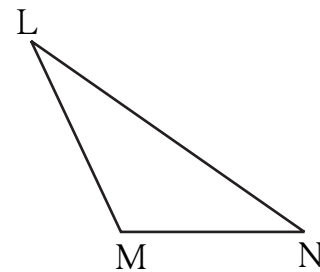
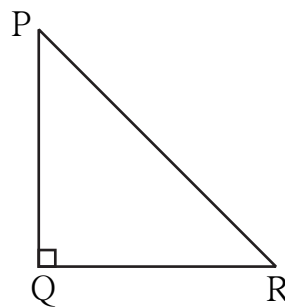
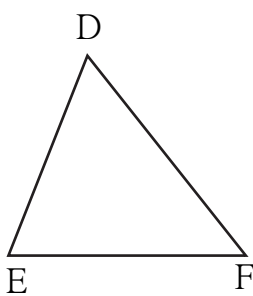

| In $\triangle DEF$ | In $\triangle PQR$ | In $\triangle LMN$ |
|--|--|---|
| Measure of $\angle D = m\angle D = \dots^\circ$ | Measure of $\angle P = m\angle P = \dots^\circ$ | Measure of $\angle L = \dots^\circ$ |
| Measure of $\angle E = m\angle E = \dots^\circ$ | Measure of $\angle Q = \dots = \dots^\circ$ | Measure of $\angle M = \dots^\circ$ |
| Measure of $\angle F = \dots = \dots^\circ$ | Measure of $\angle R = \dots = \dots^\circ$ | Measure of $\angle N = \dots^\circ$ |
| Observations: All three angles are acute angles. | One angle is a right angle and two are acute angles. | One angle is an obtuse angle and two are acute. |

In the figures above, $\triangle DEF$ is an acute angled triangle.

A triangle with all three acute angles is called an acute angled triangle.

$\triangle PQR$ is a right angled triangle.

A triangle with one right angle is a right angled triangle.

$\triangle LMN$ is an obtuse angled triangle.

A triangle with one obtuse angle is called an obtuse angled triangle.

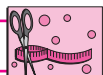

Try this.

Observe the set squares in your compass box.
What kind of triangles are they?

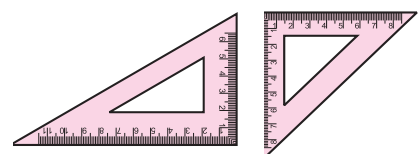



Try this.

Properties of a Triangle

Activity : Take a triangular piece of paper. Choose three different colours or signs to mark the three corners of the triangle on both sides of the paper. Fold the paper at the midpoints of two sides as shown in the pictures.

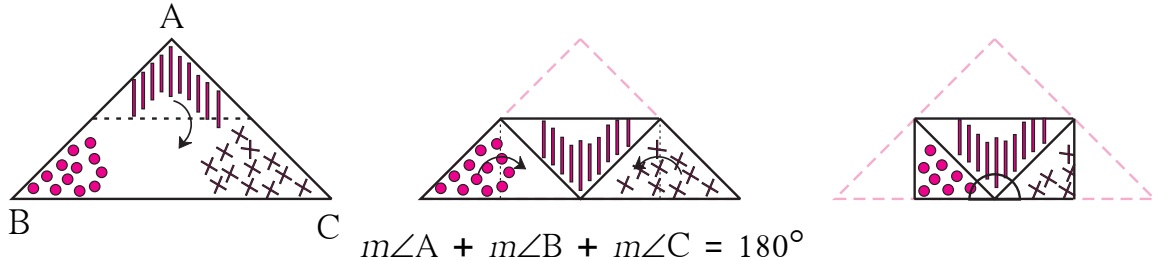

Activity : Take a triangular piece of paper and make three different types of marks near the three angles. Take a point approximately at the centre of the triangle. From this point, draw three lines that meet the three sides. Cut the paper along those lines. Place the three angles side by side as shown.

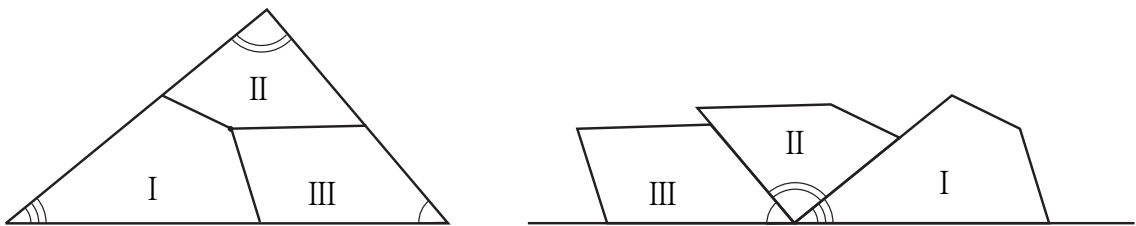

See how the three angles of a triangle together form a straight angle, or, an angle that measures 180° .



Now I know -

The sum of the measures of the three angles of a triangle is 180° .

Activity : Draw any triangle on a paper. Name its vertices A, B, C. Measure the lengths of its three sides using a divider and scale and enter them in the table.

| Length of side | Sum of the length of two sides | Length of the third side |
|--------------------|--------------------------------|--------------------------|
| $l(AB) = \dots$ cm | $l(AB) + l(BC) = \dots$ cm | $l(AC) = \dots$ cm |
| $l(BC) = \dots$ cm | $l(BC) + l(AC) = \dots$ cm | $l(AB) = \dots$ cm |
| $l(AC) = \dots$ cm | $l(AC) + l(AB) = \dots$ cm | $l(BC) = \dots$ cm |



Now I know -

The sum of the lengths of any two sides of a triangle is always greater than the length of the third side.

Practice Set 36

1. Observe the figures below and write the type of the triangle based on its angles.

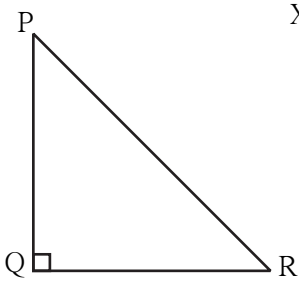

$\triangle PQR$ is triangle.

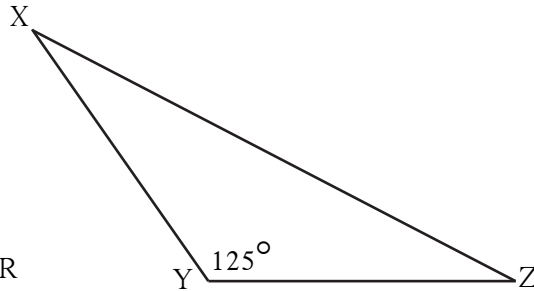

$\triangle XYZ$ is triangle.

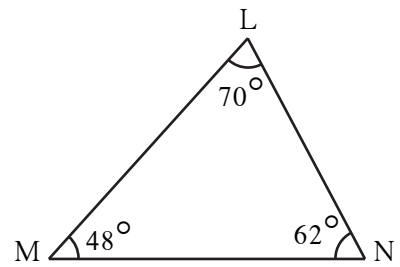

$\triangle LMN$ is triangle.

2. Observe the figures below and write the type of the triangle based on its sides.

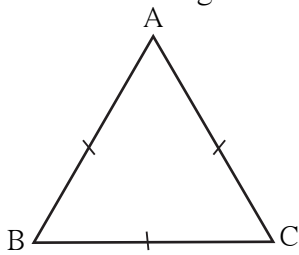

$\triangle ABC$ is triangle.

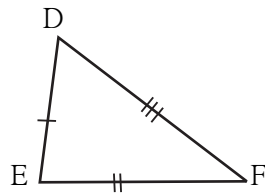

$\triangle DEF$ is triangle.

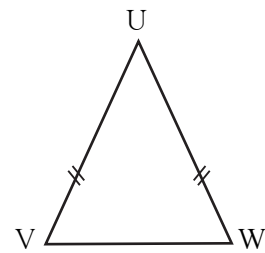

$\triangle UVW$ is triangle.

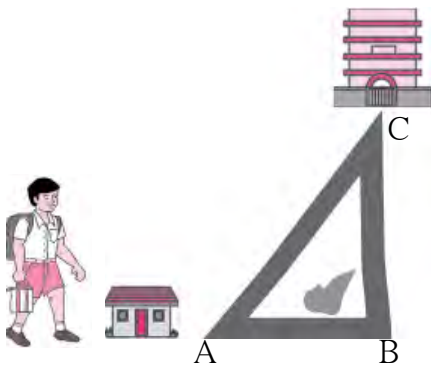

3. As shown in the figure, Avinash is standing near his house. He can choose from two roads to go to school. Which way is shorter? Explain why.

4. The lengths of the sides of some triangles are given. Say what types of triangles they are.

(1) 3 cm, 4 cm, 5 cm

(2) 3.4 cm, 3.4 cm, 5 cm

(3) 4.3 cm, 4.3 cm, 4.3 cm

(4) 3.7 cm, 3.4 cm, 4 cm

5. The lengths of three segments are given for constructing a triangle. Say whether a triangle with these sides can be drawn. Give the reason for your answer.

(1) 17 cm, 7 cm, 8 cm

(2) 7 cm, 24 cm, 25 cm

(3) 9 cm, 6 cm, 16 cm

(4) 8.4 cm, 16.4 cm, 4.9 cm

(5) 15 cm, 20 cm, 25 cm

(6) 12 cm, 12 cm, 16 cm





Let's learn.

Quadrilaterals

Take four points A, B, C, D, on a paper, such that any three of them will be non-collinear. These points are to be joined to make a closed figure, but in such a way that when any two points are joined the other two must lie on the same side of that line.

The figure obtained by following the given rule is called a **quadrilateral**.

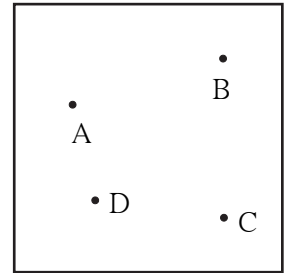

Observe the figures below and say which of them are quadrilaterals.

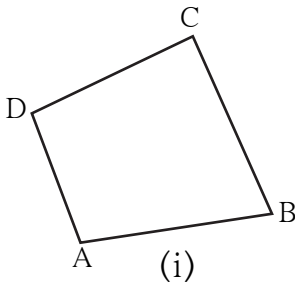

(i)

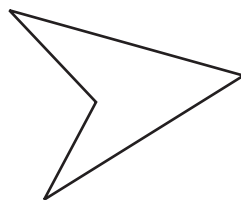

(ii)

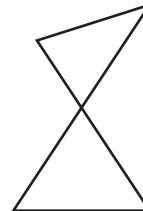

(iii)

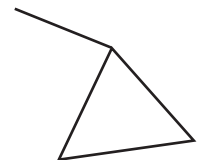

(iv)

Here, figure (i) is that of a quadrilateral.

Like a triangle, quadrilateral ABCD is a closed figure. The four line segments that form a quadrilateral are called its **sides**. Seg AB, seg BC, seg CD and seg AD are the four sides of this quadrilateral. Points A, B, C and D are the **vertices** of the quadrilateral.

Reading and Writing of a Quadrilateral

- A quadrilateral can be named by starting at any vertex and going serially either **clockwise** or **anti-clockwise** around the figure.

When writing the name of a quadrilateral a sign like this '□' is put in place of the word 'quadrilateral'.

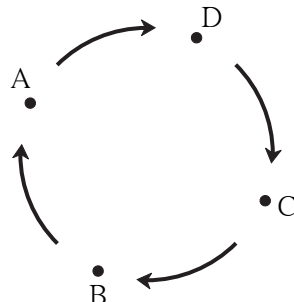
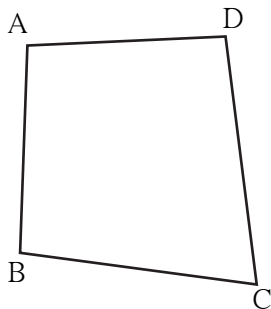

Reading

Quadrilateral ADCB
 Quadrilateral DCBA
 Quadrilateral CBAD
 Quadrilateral BADC

Writing

□ ADCB
 □ DCBA
 □ CBAD
 □ BADC

Write the names of this quadrilateral starting at any vertex and going anti-clockwise around the figure.

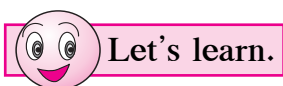

Adjacent Sides of a Quadrilateral

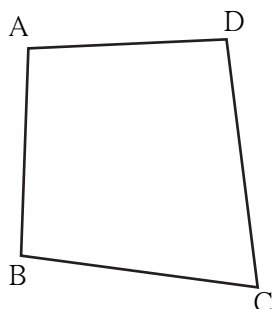

The sides AB and AD of $\square ABCD$ have a common vertex A. Sides AB and AD are **adjacent** sides.

Name the pairs of adjacent sides in the figure alongside.

- (1) and (2) and
(3) and (4) and

Every quadrilateral has four pairs of adjacent sides.

Adjacent sides of the quadrilateral have a common vertex.

Opposite Sides of a Quadrilateral

In $\square ABCD$ the sides AB and DC have no **common vertex**. Side AB and side DC are **opposite sides** of the quadrilateral.

Name the pairs of opposite sides of this quadrilateral.

Pairs of opposite sides:

- (1) and (2) and

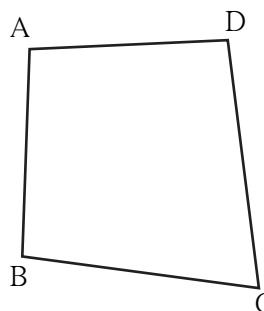

Opposite sides of the quadrilateral do not have a common vertex.

Adjacent Angles of a Quadrilateral

Take four straws/ sticks/ strips all of different lengths. Join them to each other to make a quadrilateral.

Draw its figure. We get the quadrilateral $\square DEFG$. The two angles $\angle DEF$ and $\angle GFE$ have a common arm EF. These angles are neighbouring or adjacent angles.

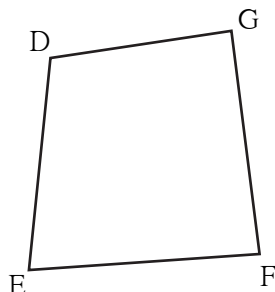

Name the adjacent angles of the quadrilateral DEFG.

- (1) and (2) and
(3) and (4) and

The angles of a quadrilateral which have one common arm are called adjacent angles of the quadrilateral.



Opposite Angles of a Quadrilateral

In \square DEFG, the angles \angle DEF and \angle DGF do not have any common arm. \angle DEF and \angle DGF lie **opposite** to each other. Hence they are the **opposite angles** of a quadrilateral. Name the other opposite angles in the figure.

1. Angle opposite to \angle EFG is 2. Angle opposite to \angle FGD is

The angles of a quadrilateral which do not have a common arm are called opposite angles of a quadrilateral.

Diagonals of a Quadrilateral

In \square ABCD, the line segments that join the vertices of the opposite angles \angle A and \angle C, as also of \angle B and \angle D, have been drawn. The segments AC and BD are the diagonals of the quadrilateral ABCD. The diagonal AC joins the vertices of the opposite angles \angle A and \angle C.

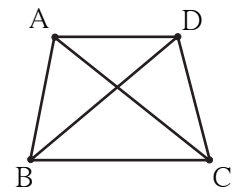

The line segments which join the vertices of the opposite angles of a quadrilateral are the diagonals of the quadrilateral.

In the figure above, name the angles whose vertices are joined by the diagonal BD.

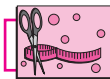

Try this.

- Cut out a paper in the shape of a quadrilateral. Make folds in it that join the vertices of opposite angles. What can these folds be called?

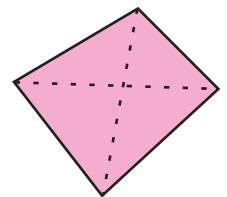
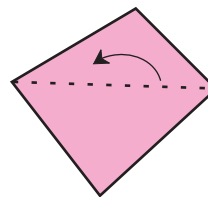
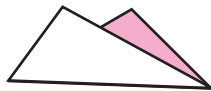
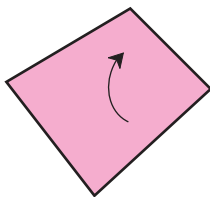

- Take two triangular pieces of paper such that one side of one triangle is equal to one side of the other. Let us suppose that in \triangle ABC and \triangle PQR, sides AC and PQ are the equal sides.

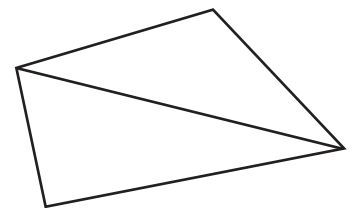
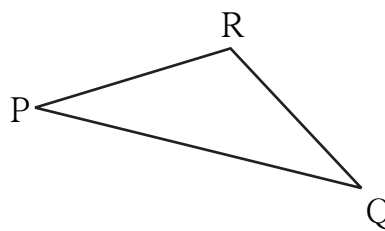
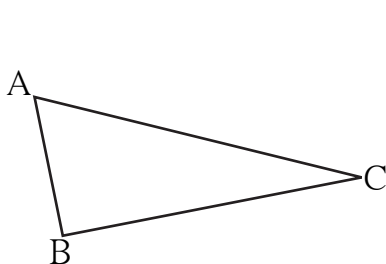

- Join the triangles so that their equal sides lie side by side.

What figure do we get?

We used two triangles to obtain a quadrilateral. The sum of the three angles of a triangle is 180° . Hence, what will the sum of the angles of a quadrilateral be?



Try this.

Draw a quadrilateral. Draw one diagonal of this quadrilateral and divide it into two triangles. Measure all the angles in the figure.

Is the sum of the measures of the four angles of the quadrilateral equal to the sum of the measures of the six angles of the two triangles?

Verify that this is so with other quadrilaterals.

$$\therefore \text{The sum of the measures of the four angles of a quadrilateral} \\ = 180^\circ + 180^\circ = 360^\circ$$

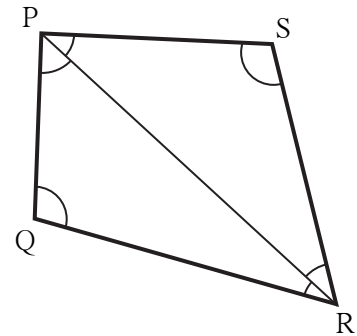

Now I know -

The sum of the measures of the four angles of a quadrilateral is 360° .



Let's learn.

Polygons

- You must have seen the five-petal flowers of *tagar*, *kunda* or *sadaphuli*.

Draw a picture of one of those flowers. Join the tips of the petals one by one. What is the figure you get? The closed figure obtained in this way by joining five points by five line segments is called a **pentagon**.

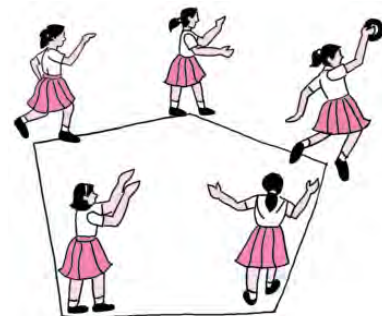
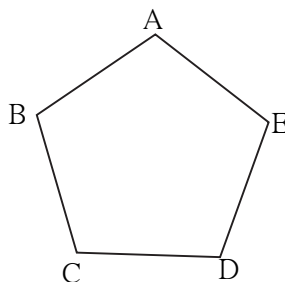
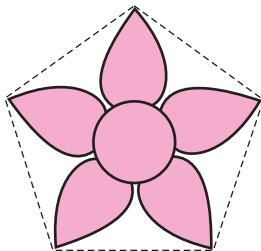

- Write the names of the vertices of the pentagon.
- Name the sides of the pentagon.
- Name the angles of the pentagon.
- See if you can sometimes find players on a field forming a pentagon.

Triangles, quadrilaterals, pentagons and other closed figures with more than five sides are all called **polygons**.

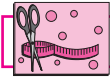

Try this.

Cut out a pentagonal piece of paper. How many triangles do we get if we fold or cut along the dotted lines shown in the figure? Now can you find the sum of the angles of a pentagon?

- Make other triangles by folding in different ways. Note your observations.

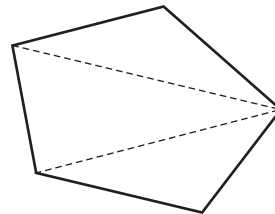
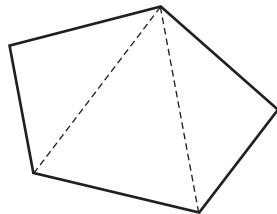

Practice Set 37

* Observe the figures below and find out their names.

| Figure | Name | Figure | Name |
|--------|------|--------|------|
| (1) | | (3) | |
| (2) | | (4) | |

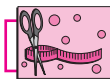

Try this.

Do this activity in groups of four. From your compass boxes, collect set squares of the same shapes and place them side by side in all possible different ways. What figures do you get? Write their names.

- (a) Two set squares (b) Three set squares (c) Four set squares

Practice Set 38

1. Draw $\square XYZW$ and name the following.
 - (1) The pairs of opposite angles.
 - (2) The pairs of opposite sides.
 - (3) The pairs of adjacent sides.
 - (4) The pairs of adjacent angles.
 - (5) The diagonals of the quadrilateral.
 - (6) The name of the quadrilateral in different ways.

2. In the table below, write the number of sides the polygon has.

| Names | Quadrilateral | Octagon | Pentagon | Heptagon | Hexagon |
|-----------------|---------------|---------|----------|----------|---------|
| Number of sides | | | | | |

3. Look for examples of polygons in your surroundings. Draw them.

4. We see polygons when we join the tips of the petals of various flowers. Draw these polygons and write down the number of sides of each polygon.

5. Draw any polygon and divide it into triangular parts as shown here. Thus work out the sum of the measures of the angles of the polygon.

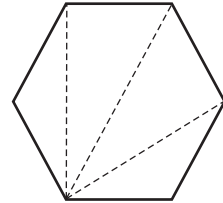

ICT Tools or Links

With the help of the Paint program on a computer, draw various polygons and colour them. Make figures of regular polygons with the help of the Geogebra software.

Kaprekar Number

Take any 4-digit number in which all the digits are not the same.

Obtain a new 4-digit number by arranging the digits in descending order.

Obtain another 4-digit number by arranging the digits of the new number in ascending order.

Subtract the smaller of these two new numbers from the bigger number. The difference obtained will be a 4-digit number. If it is a 3-digit number, put a 0 in the thousands place. Repeat the above steps with the difference obtained as a result of the subtraction.

After some repetitions, you will get the number 6174. If you continue to repeat the same steps you will get the number 6174 every time. Let us begin with the number 8531.

$8531 \longrightarrow 7173 \longrightarrow 6354 \longrightarrow 3087 \longrightarrow 8352 \longrightarrow 6174 \longrightarrow 6174$

This discovery was made by the mathematician, Dattatreya Ramchandra Kaprekar. That is why the number 6174 was named the **Kaprekar number**.





Can you tell?

- (1) When constructing a building, what is the method used to make sure that a wall is exactly upright? What does the mason in the picture have in his hand? What do you think is his purpose for using it?
- (2) Have you looked at lamp posts on the roadside? How do they stand?

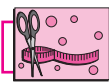

Try this.

The Perpendicular

In the figure here, line l and line n intersect at point M . Measure every angle formed at the point M .

If an angle between line l and line n is a right angle, we say that the lines are **perpendicular** to each other. This is written as 'line $l \perp$ line n ' in symbols. It is read as 'Line l is perpendicular to line n '.

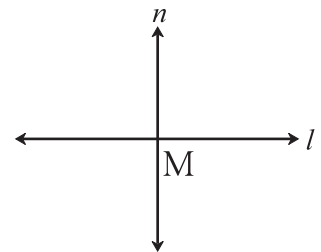

◆ Drawing a perpendicular to a line at a point on the line.

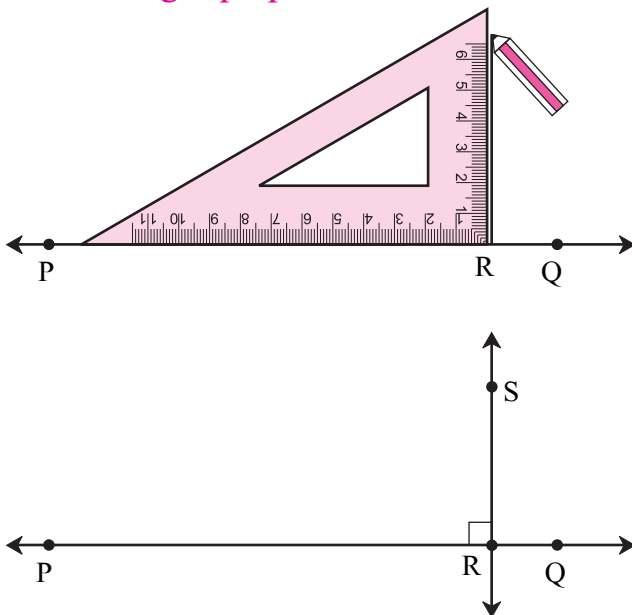

(1) Using a set square

- Draw line PQ . Take point R anywhere on the line.
- Place the set square on the line in such a way that the vertex of its right angle is at point R and one arm of the right angle falls on line PQ .
- Draw a line RS along the other arm of the right angle of the set square.
- The line RS is perpendicular to the line PQ at R .

(2) Using a protractor

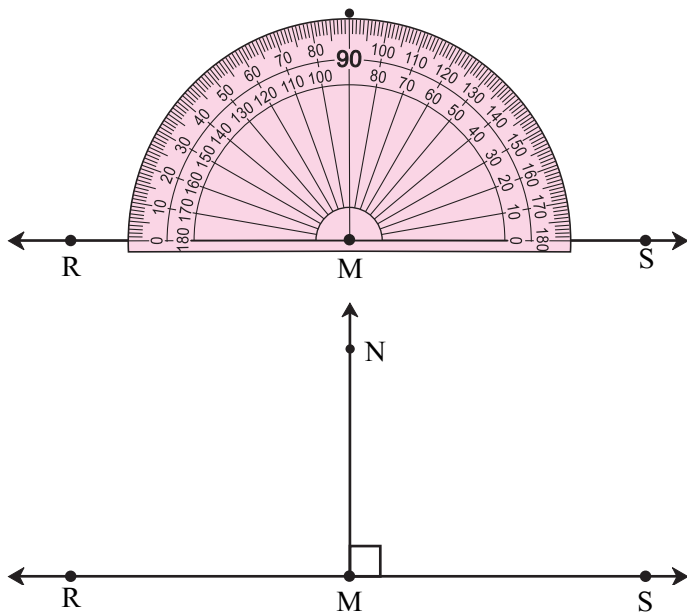

- Draw line RS. Take point M anywhere on the line.
- In order to draw a perpendicular through M, place the centre of the protractor on point M, as shown.
- Mark a point N at the 90° mark on the protractor.
- Draw a line passing through points M and N.
- The line MN is perpendicular to line RS at M.

Line $MN \perp$ line RS.

(3) Using a compass

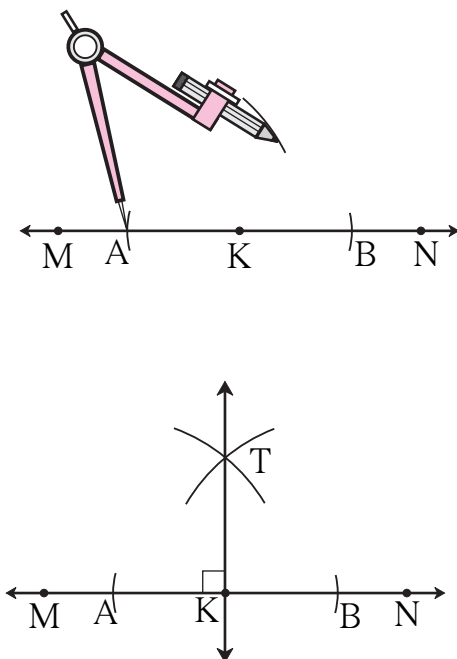

- Draw line MN. Take point K anywhere on the line.
 - Place the compass point on point K. Draw two arcs on either side of point K to cut the line MN at equal distances from K. Name the points of intersection A and B respectively.
 - Place the compass point at A and, taking a convenient distance greater than half the length of AB, draw an arc on one side of the line.
 - Place the compass point at B and using the same distance, draw another arc to intersect the first one at T.
 - Draw a line passing through points K and T.
 - The line KT is perpendicular to line MN at K.
- Line $KT \perp$ line MN.



Think about it.

Why must we take a distance greater than half of the length of AB?

What will happen if we take a smaller distance?

Practice Set 39

1. Draw line l . Take any point P on the line. Using a set square, draw a line perpendicular to line l at the point P.
2. Draw a line AB. Using a compass, draw a line perpendicular to AB at the point B.
3. Draw line CD. Take any point M on the line. Using a protractor, draw a line perpendicular to line CD at the point M.

◆ **Drawing a perpendicular to a line from a point outside the line.**

(1) By folding the paper

- Draw a line MN on a paper.
Take a point P anywhere outside the line.
- Keeping the line MN in view, fold the paper along the line MN.
- Now fold the paper through point P in such a way that the part of line MN on one side of the fold falls on the part of line MN on the other side of the fold.
- Unfold the paper. Name the point of intersection of the two folds Q. Draw the line PQ. This line falls on a fold in the paper.

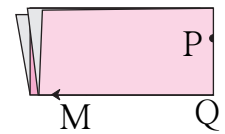
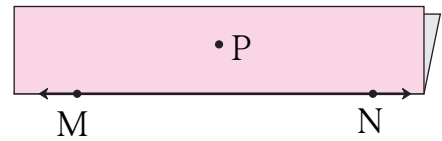
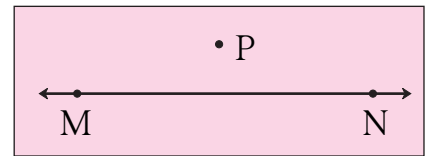

Using a protractor, measure every angle formed at the point Q .

Line PQ is perpendicular to line MN.

Line $PQ \perp$ line MN.

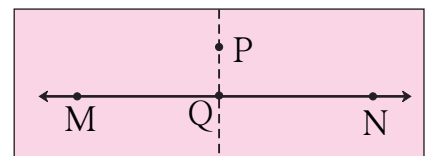

(2) Using a set square

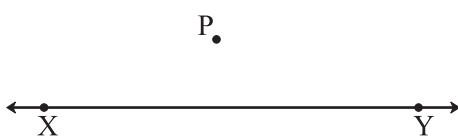

- Draw line XY. Take point P anywhere outside XY.
- Place one of the arms of the right angle of a set square along the line XY.

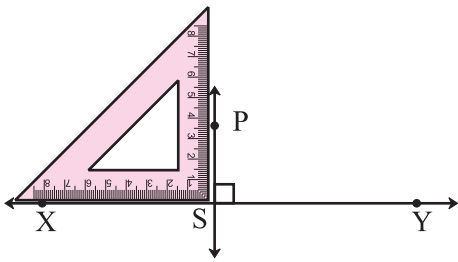

- Slide the set square along the line in such a way that the other arm of its right angle touches point P. Draw a line along this side, passing through point P. Name the line PS. Measure the angles to verify that the line is a perpendicular.

(3) Using a compass and ruler

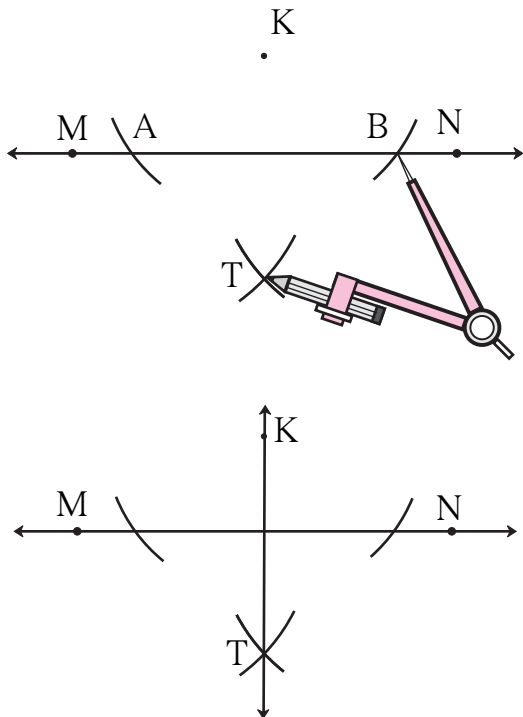

- Draw line MN. Take any point K outside the line.
- Placing the compass point at point K and using any convenient distance, draw arcs to cut the line MN at two points A and B.
- Place the compass point at A and taking a distance greater than half of AB, draw an arc on the lower side of line MN.
- Place the compass point at B and using the same distance, draw an arc to cut the previous arc at T.
- Draw the line KT.
- Line KT is perpendicular to line MN. Verify.



Think about it.

In the above construction, why must the distance in the compass be kept constant?

The Perpendicular Bisector

A wooden 'yoke' is used for pulling a bullock cart.

How is the position of the yoke determined?

To do that, a rope is used to measure equal distances from the spine/ midline of the bullock cart. Which geometrical property is used here?

Find out from the craftsmen or from other experienced persons, why this is done.

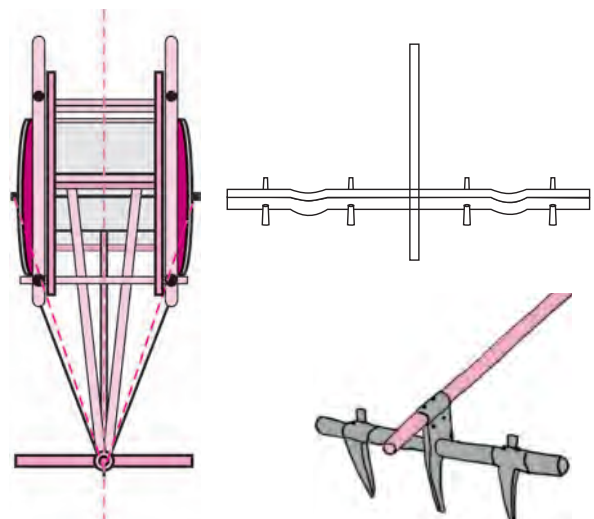

The Perpendicular Bisector of a Line Segment

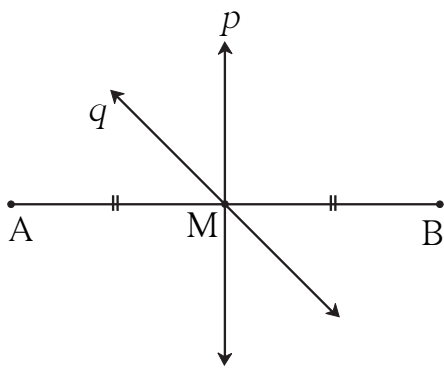

Line p and line q pass through the point M on seg AB .
 Line p and line q are bisectors of the segment AB .
 Measure the angle between line p and seg AB .
 Of the two lines p and q , line p is a bisector and also perpendicular to seg AB .
 Hence, line p is called the **perpendicular bisector** of seg AB .
 Why is line q not a perpendicular bisector of seg AB ?

◆ Drawing the perpendicular bisector of a segment, using a compass.

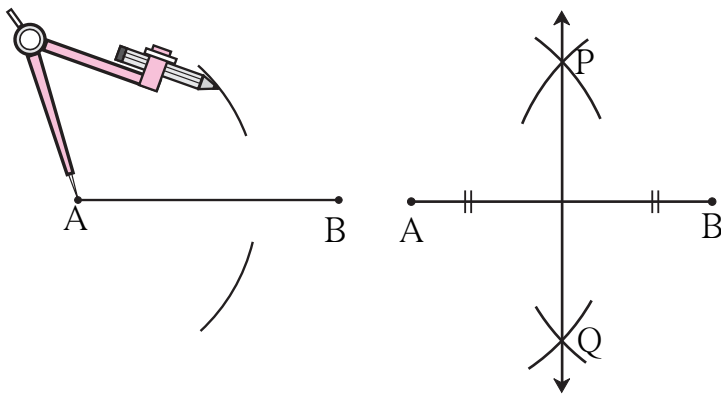

- Draw seg AB .
- Place the compass point at A and taking a distance greater than half the length of seg AB , draw two arcs, one below and one above seg AB .
- Place the compass point at B and using the same distance draw arcs to intersect the previous arcs at P and Q . Draw line PQ .

- The line PQ is the perpendicular bisector of seg AB . Verify.

Try this.

Activity : Take a rectangular sheet of paper. Fold the paper so that the lower edge of the paper falls on its top edge and fold it over again from right to left. Observe the two folds that have formed on the paper. Verify that each fold is a perpendicular bisector of the other. Then measure the distances to fill in the blanks below.

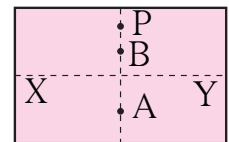
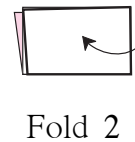
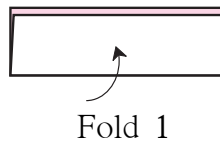
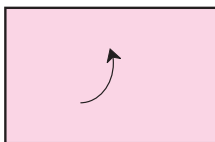

$l(XP) = \dots\dots\dots$ cm

$l(XA) = \dots\dots\dots$ cm

$l(XB) = \dots\dots\dots$ cm

$l(YP) = \dots\dots\dots$ cm

$l(YA) = \dots\dots\dots$ cm

$l(YB) = \dots\dots\dots$ cm

You will see that all points on the vertical fold are equidistant from the endpoints of the horizontal fold.

Practice Set 40

1. Draw line l . Take point P anywhere outside the line. Using a set square, draw a line PQ perpendicular to line l .
2. Draw line AB. Take point M anywhere outside the line. Using a compass and ruler, draw a line MN perpendicular to line AB.
3. Draw a line segment AB of length 5.5 cm. Bisect it using a compass and ruler.
4. Take a point R on line XY. Draw a line perpendicular to XY at R, using a set square.



Carl Gauss's Clever Trick

This is a story from the childhood of the great mathematician Carl Friedrich Gauss. The boys in Carl's class were making a lot of noise. To keep them occupied, their teacher set them the task of adding up all the numbers from 1 to 100. Carl completed the task in two or three minutes and sat quietly with arms crossed. Other children, for fear of the teacher, kept on with their calculations.

'Don't be idle! Do what I told you,' shouted the teacher angrily.

Carl showed the teacher his addition. The teacher was astonished to see that he had the correct answer.

How had Carl carried out the addition ?

| | | | | | | | | | | | | |
|---|-----|----|-----|-------|-----|-----|-------------------|---|-----|---|-----|-----------------|
| + | 1 | 2 | 3 | | 99 | 100 | (Hundred numbers) | | | | | |
| | 100 | 99 | 98 | | 2 | 1 | (Hundred numbers) | | | | | |
| | | | | | | | | | | | | |
| | 101 | + | 101 | + | 101 | + | | + | 101 | + | 101 | (Hundred times) |

That would be 101×100 .

But this is the sum of numbers from 1 to 100, taken twice.

Therefore, the sum of all the numbers from 1 to 100 would be

$$\frac{101 \times 100}{2} = 101 \times 50 = 5050$$

You could try using Carl's method to find the sum of numbers from 1 to 50.





Let's recall.

Cuboids or Rectangular Prisms

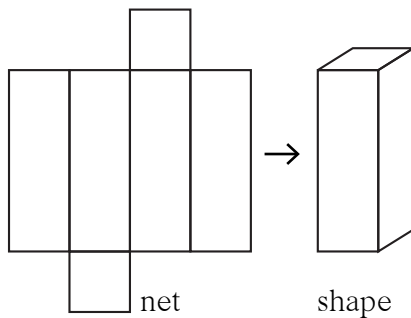

You have learnt to make a cuboid from its net.

Give examples of how the same shape can be obtained in other ways.

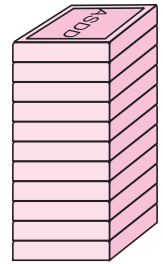

Let's learn.

Rectangular Prisms

All the faces of a cuboid are rectangular and its opposite faces are identical or congruent. The cuboid is also a **quadrangular prism**. How many edges does the cuboid have? How many vertices does it have? How many faces does it have?

In the figure here, points A and B are two of the eight vertices. Seg AB and seg AP are the names of two edges and ABCD is the name of one face.

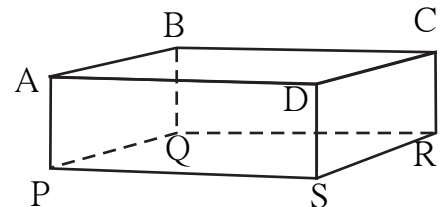

A cuboid has **12 edges**, **8 vertices** and **6 faces**.

Cubes

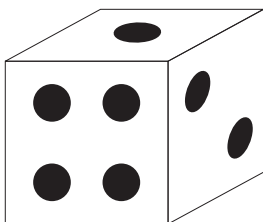

There is a dice in the figure alongside. What difference do you see in the shape of a dice and that of a cuboid? When all the faces of a quadrangular prism are equal squares, it is called a cube.

- How many faces does a cube have?
- How many edges does a cube have?
- How many vertices does a cube have?

Triangular Prisms

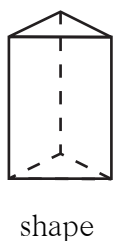
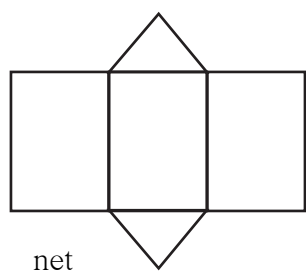

What is the shape of the faces at the base and at the top of the figure alongside?

What is the shape of the faces on the sides?

Such a figure is called a **triangular prism**.

How many edges, vertices and faces does a triangular prism have?

Cylinders

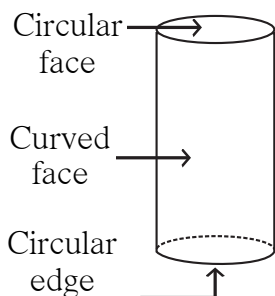

You must have seen a tall box with a circular base. A tin like this is a familiar example of a cylinder. If the tin is closed, it is a closed cylinder. A closed cylinder has two flat circular faces and one curved face. The cylinder has two circular edges and no vertex.

Give some examples of cylinders you are familiar with.

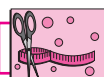

Try this.

- Activity :**
- Take a rectangular sheet.
 - Bring together its opposite sides.
 - A hollow cylinder will be formed.

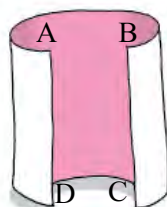

Activity : Take a cylindrical tin. Take a rectangular sheet with one side equal to the height of the tin. Wrap it around the tin to cover it completely and cut away the extra paper. Then unfold it and spread it out on a table.

Take another sheet. Place the box on it and draw its circular outline. Cut away the paper around it. Cut out another circle like this one. Place these discs next to the rectangular paper as shown in the figure above. The figure obtained is the net of the closed cylinder. Make a cylinder using this net.

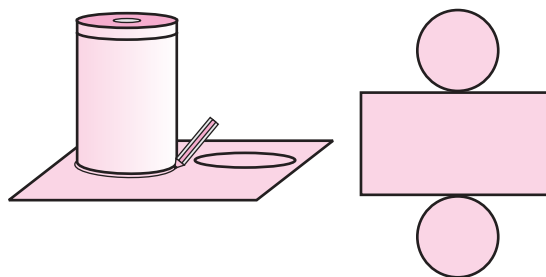

Can you tell?

When playing carrom, you make a pile of the pieces as shown in the picture. What is the shape of this pile?

If you place a number of CD's or round biscuits one on top of the other, what shape do you get?

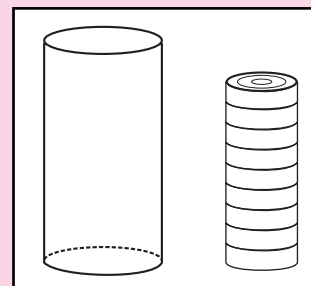

Try this.

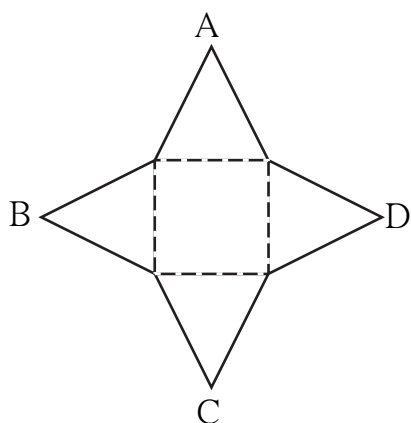

This shape is called a **pyramid**. The top or apex of this shape is pointed like a needle. As the base of this shape is a quadrilateral, it is called a **quadrangular pyramid**. Count the edges, vertices and faces of this shape.

A quadrangular pyramid has 5 faces, 8 edges and 5 vertices.

Activity : Draw the net shown alongside on a card-sheet and cut it out. Fold along the dotted lines of the triangle in the centre and bring together the triangles on the sides so that the vertices A, B and C meet at a point. You will get a pyramid. The base of this pyramid is a triangle. Hence, it is called a **triangular pyramid**. Count and write the number of its edges, vertices and faces.

Pyramids

Activity : A net is shown here. It has identical triangular sides. Draw a figure like this on a card-sheet and cut it out. Fold along the dotted lines of the square and bring the sides together so that the vertices A, B, C and D meet at a point.

You will get a shape like the one shown below. Its base is a square and its other standing faces are triangles.

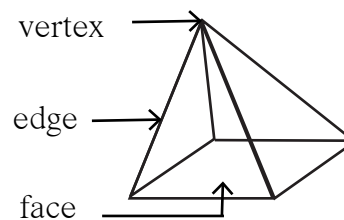

Quadrangular Pyramid

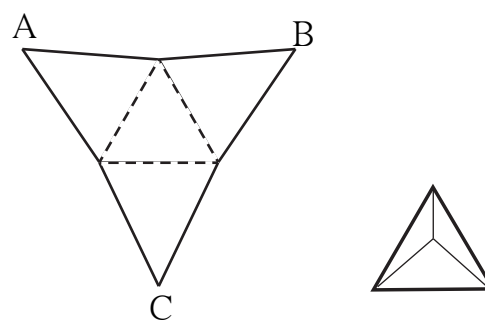

Triangular Pyramid



Now I know -

The top and the bottom faces of a prism are identical. The other faces of triangular, quadrangular, etc. prisms are rectangular.

The standing faces of a pyramid are triangular.

The name of a prism or a pyramid depends upon the shape of its base.

Cones

You are familiar with examples of cones.

You can see two of them in the pictures below.



This cone has been closed after filling it with ice-cream. Its circular top is closed.

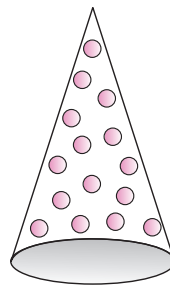

This is a clown's cap. The circular base of this cap is not closed.

The tip of the cone is called its **apex**. A cone that is closed by a flat disc has one curved face, one circular flat face and one circular edge.

An open cone has a curved face and a circular edge, but no flat face.

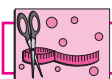
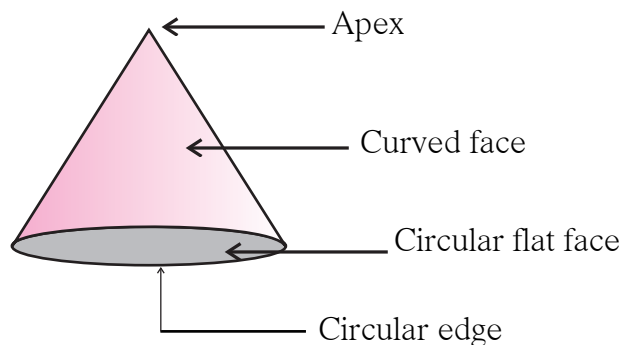

Try this.

- Using a compass, draw a circle with centre C on a paper.
- Draw two radii of the circle, CR and CS.
- Cut out the circle.
- Cut along the radii and obtain two pieces of the circle.
- Bring together the sides CR and CS of each piece.

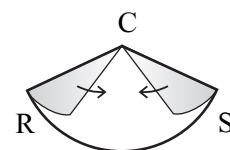
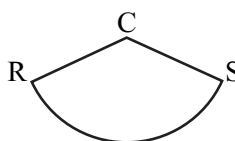
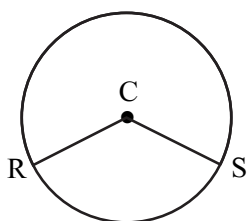
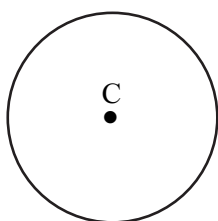

On completing the activity, what shapes did you get?



Spheres

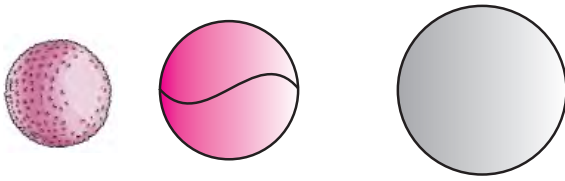





The shape of a laddoo, a ball, a shot put is called a sphere.

The sphere has just **one curved face**.

It does not have any vertices or edges.

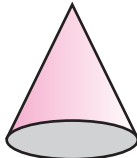
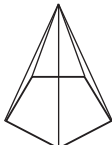
Practice Set 41

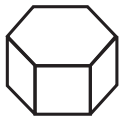
- * Write the number of faces, edges and vertices of each shape in the table.

| Name | Cylinder | Cone | Pentagonal pyramid | Hexagonal pyramid | Hexagonal prism | Pentagonal prism |
|----------|--|--|--|---|--|--|
| Shape |  |  |  |  |  |  |
| Faces | | | | | | |
| Vertices | | | | | | |
| Edges | | | | | | |



Answers

Practice Set 1

- (1) Collinear points: (i) point M, point O, point T (ii) point R, point O, point N
 (2) ray OM, ray OP, ray ON, ray OT, ray OS, ray OR
 (3) seg MT, seg RN, seg OP, seg ON, seg OT, seg OS, seg OR, seg OM
 (4) line MT, line RN
- line l , line AB, line AC, line AD, line BC, line BD, line CD
- (i) \leftrightarrow (c), (ii) \leftrightarrow (d), (iii) \leftrightarrow (b), (iv) \leftrightarrow (a)
- Parallel lines: (i) line b , line m , line q (ii) line a , line p
 Concurrent lines: (i) line a , line b , line c , line AC (ii) line p , line q , line AD
 Point of concurrence : Point A, Point D

Practice Set 2

- (1) \leftrightarrow (b), (2) \leftrightarrow (c), (3) \leftrightarrow (d), (4) \leftrightarrow (a)
- (1) acute angle (2) zero angle (3) reflex angle (4) complete angle
 (5) straight angle (6) obtuse angle (7) obtuse angle (8) right angle
- (a) acute angle (b) right angle (c) reflex angle (d) straight angle (e) zero angle
 (f) complete angle

Practice Set 3

Practice Set 4

- Negative numbers: $-5, -2, -49, -37, -25, -4, -12$
 Positive numbers: $+4, 7, +26, 19, +8, 5, 27$
- Shimla: -7°C , Leh: -12°C , Delhi: $+22^\circ\text{C}$, Nagpur: $+31^\circ\text{C}$
- (1) -512 m (2) 8848 m (3) 120 m (4) -2 m

Practice Set 5

- (1) 14 (2) 6 (3) -1 (4) -5 (5) -8 (6) -7

2.

| | | | | |
|----|---------------|----|----|----|
| + | 8 | 4 | -3 | -5 |
| -2 | $-2 + 8 = +6$ | 2 | -5 | -7 |
| 6 | $6 + 8 = 14$ | 10 | 3 | 1 |
| 0 | $0 + 8 = 8$ | 4 | -3 | -5 |
| -4 | $-4 + 8 = 4$ | 0 | -7 | -9 |

Practice Set 6

| | | | | | | | | |
|------------------|-----|-----|-----|-----|-----|-----|-----|-----|
| Numbers | 47 | +52 | -33 | -84 | -21 | +16 | -26 | 80 |
| Opposite Numbers | -47 | -52 | +33 | +84 | +21 | -16 | +26 | -80 |

Practice Set 7

| | | | |
|---------------|----------------|---------------|------------------|
| (1) $-4 < 5$ | (2) $8 > -10$ | (3) $+9 = +9$ | (4) $-6 < 0$ |
| (5) $7 > 4$ | (6) $3 > 0$ | (7) $-7 < 7$ | (8) $-12 < 5$ |
| (9) $-2 > -8$ | (10) $-1 > -2$ | (11) $6 > -3$ | (12) $-14 = -14$ |

Practice Set 8

| | | | | | | | | |
|----|----|-----|----|----|----|-----|----|----|
| - | 6 | 9 | -4 | -5 | 0 | +7 | -8 | -3 |
| 3 | -3 | -6 | 7 | 8 | 3 | -4 | 11 | 6 |
| 8 | 2 | -1 | 12 | 13 | 8 | 1 | 16 | 11 |
| -3 | -9 | -12 | 1 | 2 | -3 | -10 | 5 | 0 |
| -2 | -8 | -11 | 2 | 3 | -2 | -9 | 6 | 1 |

Practice Set 9

- (i) $\frac{37}{5}$ (ii) $\frac{31}{6}$ (iii) $\frac{19}{4}$ (iv) $\frac{23}{9}$ (v) $\frac{12}{7}$
- (i) $4\frac{2}{7}$ (ii) $1\frac{3}{4}$ (iii) $1\frac{3}{12}$ or $1\frac{1}{4}$ (iv) $1\frac{3}{8}$ (v) $5\frac{1}{4}$ (vi) $2\frac{6}{7}$
- (i) $\frac{9}{5}$ kg (ii) $\frac{11}{5}$ m

Practice Set 10

- (i) $8\frac{2}{3}$ (ii) $4\frac{3}{4}$ (iii) $7\frac{12}{35}$ (iv) $5\frac{8}{15}$
- (i) $2\frac{1}{12}$ (ii) $2\frac{1}{6}$ (iii) $1\frac{1}{40}$ (iv) $4\frac{3}{10}$
- (1) 6 kg, ₹192 (2) $\frac{4}{15}$ (3) 340 l

Practice Set 11

1. (1) $\frac{5}{6}, \frac{10}{6}$ (2) $\frac{3}{5}, \frac{7}{5}$ (3) $\frac{3}{7}, \frac{10}{7}$

Practice Set 12

1. (i) $\frac{7}{20}$ (ii) $\frac{12}{35}$ (iii) $\frac{20}{81}$ (iv) $\frac{8}{77}$ (v) $\frac{7}{10}$ (vi) $\frac{9}{8}$ (vii) 1 (viii) $\frac{9}{17}$
2. 6 acres
3. 1,80,000

Practice Set 13

1. (i) $\frac{1}{7}$ (ii) $\frac{3}{11}$ (iii) $\frac{13}{5}$ (iv) $\frac{1}{2}$ (v) $\frac{7}{6}$
2. (i) $\frac{8}{3}$ (ii) $\frac{10}{27}$ (iii) $\frac{33}{35}$ (iv) $\frac{77}{48}$
3. $\frac{1}{750}$ part

Practice Set 14

1. Place Value: 70, 8, 0.02
2. (1) 932.697 (2) 739.65 (3) 70.151
3. (1) 83.615 (2) 534.79 (3) 182.819
4. 55.465 km
5. ₹ 486 6. 2.5 kg 7. 30.6 km

Practice Set 15

1. (1) $\frac{3}{5} = \frac{3 \times \boxed{2}}{5 \times \boxed{2}} = \frac{\boxed{6}}{10} = \boxed{0.6}$ (2) $\frac{25}{8} = \frac{25 \times \boxed{125}}{8 \times \boxed{125}} = \frac{\boxed{3125}}{1000} = 3.125$
- (3) $\frac{21}{2} = \frac{21 \times \boxed{5}}{2 \times \boxed{5}} = \frac{\boxed{105}}{10} = \boxed{10.5}$ (4) $\frac{22}{40} = \frac{11}{20} = \frac{11 \times \boxed{5}}{20 \times \boxed{5}} = \frac{\boxed{55}}{100} = \boxed{0.55}$
2. (1) 0.75 (2) 0.8 (3) 1.125 (4) 0.85 (5) 0.9 (6) 0.28 (7) 0.095
3. (1) $\frac{275}{10}$ (2) $\frac{7}{1000}$ (3) $\frac{908}{10}$ (4) $\frac{3915}{100}$ (5) $\frac{312}{100}$ (6) $\frac{704}{10}$

Practice Set 16

- 14.265 2. 10.9151 3. (1) 3.78 (2) 24.063 (3) 1.14 (4) 3.528
- 94.5 kg, ₹ 3969 5. 2.25 m

Practice Set 17

- (1) 2.4 (2) 3.5 (3) 10.3 (4) 1.3 2. 1000 trees or 1002 trees
- 0.425 km 4. ₹ 38000

Practice Set 18

- * (1) Temperature on vertical line, Cities on horizontal line (2) Chandrapur
- (3) Panchgani and Matheran, Pune and Nashik (4) Pune and Nashik
- (5) 10 °C

Practice Set 19

Practice Set 20

- Figures having more than one axis of symmetry (1), (2) and (4)
- Letters with an axis of symmetry : A, B, C, D, E, H, I, K, M, O, T, U, V, W, X, Y
Letters having more than one axis of symmetry : H, I, O, X

Practice Set 21

Practice Set 22

- * Basket of 3 : 111, 369, 435, 249, 666, 450, 960, 432, 999, 72, 336, 90, 123, 108.
- Basket of 4 : 356, 220, 432, 960, 72, 336, 108
- Basket of 9 : 369, 666, 450, 432, 999, 72, 90, 108

Practice Set 23

- Factors of 12 : 1, 2, 3, 4, 6, 12
Factors of 16 : 1, 2, 4, 8, 16
Common Factors : 1, 2, 4

Practice Set 28

- (1) 3:7 (2) 9:7 (3) 4:5 (4) 7:5 (5) 7:13 (6) 11:9
- (1) $\frac{5}{8}$ (2) $\frac{1}{3}$ (3) $\frac{1}{4}$ (4) $\frac{5}{4}$ (5) $\frac{9}{4}$ (6) $\frac{4}{1}$ (7) $\frac{3}{5}$ (8) $\frac{3}{2}$ (9) $\frac{5}{4}$
3. $\frac{4}{3}$ 4. $\frac{3}{5}$ 5. $\frac{4}{11}$ 6. (1) $\frac{1}{3}$ (2) $\frac{6}{7}$ (3) $\frac{5}{17}$

Practice Set 29

- * (1) ₹ 2880 (2) ₹ 260 (3) ₹ 5136 (4) 216 kg (5) 6 hours, 440 km
(6) 76 litres (7) 5600 kg (8) 208 trees (9) 4 ponds, ₹ 72000

Practice Set 30

- * (1) 92% (2) 70%, 30% (3) 14625 sq.m. (4) 4 messages (5) 96%
(6) The proportion of women was greater in Jambhulgaon.

Practice Set 31

- (1) Profit ₹ 500 (2) Loss ₹ 10 (3) Profit ₹ 99 (4) Loss ₹ 80
- ₹ 400 Profit 3. ₹ 225 Profit 4. ₹ 7050 5. ₹ 50 Loss 6. ₹ 200 Loss 7. ₹ 1500 Profit

Practice Set 32

- Loss ₹ 50 2. Profit ₹ 8000 3. Loss ₹ 150 4. ₹ 941 5. Each ₹ 14500
- Profit ₹ 9240

Practice Set 33

- Transaction with the shirt was more profitable 3. 25% Profit
- Shamrao's transaction was more profitable

Practice Set 34

- 75% Profit 2. 5% Loss 3. $16\frac{2}{3}\%$ Profit 4. $7\frac{1}{2}\%$ Profit 5. $11\frac{1}{9}\%$ Profit
- 20% Loss

Practice Set 35

- ₹ 600 2. ₹ 9169 3. ₹ 28000 4. ₹ 2115

Practice Set 36

1. Right angle, Obtuse angle, Acute angle 2. Equilateral, Scalene, Isosceles
3. Road AC is shorter because the sum of the lengths of any two sides of a triangle is always greater than the third side.
4. (1) Scalene triangle (2) Isosceles triangle (3) Equilateral triangle (4) Scalene triangle
5. Triangles can be drawn. (2), (5), (6) Triangles cannot be drawn. (1), (3), (4)

Practice Set 37

- * (1) Pentagon (2) Hexagon (3) Heptagon (4) Octagon

Practice Set 38





1. (1) $\angle X$ and $\angle Z$, $\angle Y$ and $\angle W$ (2) seg XY and seg ZW, seg XW and seg YZ
 (3) seg XY and seg YZ, seg YZ and seg WZ; seg WZ and seg XW, seg XW and seg XY
 (4) $\angle X$ and $\angle Y$, $\angle Y$ and $\angle Z$, $\angle Z$ and $\angle W$, $\angle X$ and $\angle W$ (5) Diagonal XZ and Diagonal YW
 (6) $\square YZWX$, $\square ZWXY$, $\square XYZW$ etc.
2. Quadrilateral - 4, Octagon - 8, Pentagon - 5, Heptagon - 7, Hexagon - 6 5. 720°

Practice Set 39

Practice Set 40

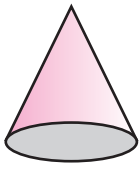
Practice Set 41

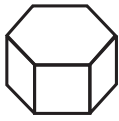
*

| Name | Cylinder | Cone | Pentagonal pyramid | Hexagonal pyramid | Hexagonal prism | Pentagonal prism |
|----------|---|---|---|--|---|---|
| Shape |  |  |  |  |  |  |
| Faces | 1 curved | 1 curved 1 flat | 6 | 7 | 8 | 7 |
| Vertices | 0 | 1 | 6 | 7 | 12 | 10 |
| Edges | 2 circular | 1 circular | 10 | 12 | 18 | 15 |





99 98 97 96 95 94 93 92 91
 $2-0$ $-2+6$ $8-(+5)$

81 82 83 84 85 86 87 88 89 90
 $7-(-1)$ $1-1$ $-6+2$ $4-0$ $-7+6$

80 79 78 77 76 75 74 73 72 71
 $-6+4$ $-2-6$ $+6-2$

61 62 63 64 65 66 67 68 69 70
 $-2+0$ $5-(-1)$ $0-(-2)$

60 59 58 57 56 55 54 53 52 51
 $8-1$ $5-2$ $-4+1$

41 42 43 44 45 46 47 48 49 50
 $4+2$ $6-(-1)$

40 39 38 37 36 35 34 33 32 31
 $-5+4$ $2-(-5)$ $7+(-4)$ $5-1$

21 22 23 24 25 26 27 28 29 30
 $-8+7$ $-5+1$ $-1+4$ $1+3$

20 19 18 17 16 15 14 13 12 11
 $-4+2$ $7-(-2)$ $-1+5$ $-2-2$

1 2 3 4 5 6 7 8 9 10
 $4+5$ $6+(-2)$ $3+1$ $-3+7$ $9-5$



Maharashtra State Bureau of Textbook Production and Curriculum Research, Pune.

इंग्रजी गणित इ. ६ वी

₹ 41.00