

9. MILK, MEAT AND EGGS

Can you tell ?

- Different livestock products.
- What do you mean by milk?
- Why milk is called as complete food?
- How milk differs from colostrum?



Livestock plays an important role in Indian economy as it provides food items such as Milk, Meat and Eggs for human consumption. Milk, meat and eggs are important sources of animal protein. Livestock provides food safety to increasing global human population and helps in reducing the malnutrition, especially in developing countries.

9.1 Milk

Milk is a whole, fresh and clean normal lacteal secretion obtained by the complete milking of healthy milch animals excluding that obtained within 15 days before or 5 days

after calving. Whereas, the first secretion of mammary gland following parturition is called as 'colostrum'.



Verghese Kurien (26 November, 1921 – 9 September, 2012) known as Milkman of India and the 'Father of the White Revolution'. He was a social entrepreneur whose "billion-litre idea" and Operation Flood programme made dairy farming India's largest self-sustaining industry and the largest rural employment provider. It made India the world's largest milk producer from a milk-deficient nation.

9.1.1 Composition of milk

Milk contains major and minor constituents. The major constituents of milk are water, fat, protein, lactose and ash or mineral matter. The minor constituents are phospholipids, vitamins, enzymes, pigments, cholesterol etc.

Table 9.1 : Average chemical composition of milk in different species.

Sr.No.	Name of Species	Milk Constituents (%)				
		Water	Fat	Protein	Lactose	Ash
1	Cow	86.8	4.6	3.2	4.7	0.7
2	Buffalo	84.2	6.6	3.9	5.2	0.8
3	Goat	86.5	4.5	3.5	4.7	0.8
4	Sheep	79.4	8.6	6.7	4.3	1.0
5	Human	87.7	3.6	1.8	6.8	0.1

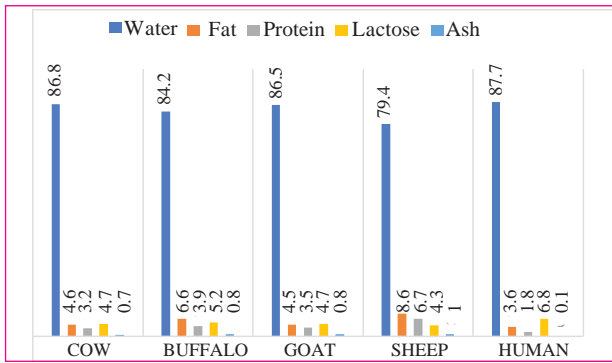

Fig. 9.1 : Composition of milk in different animal species

Constituents of milk

The details of major and minor milk constituents are as follows.

A. Major milk constituents

1. Water : It serves as a carrier for the other constituents of milk. A small amount of water in milk is hydrated to lactose and salts and bound to proteins. It ranges from 80 to 90% depending upon species and breed.

Use your brain power

Collect the information on current milk pricing on the basis of fat & SNF content of cow and buffalo milk

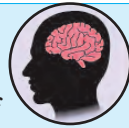

2. Fat : It is an important constituent of milk. It is available in the form of small globules ranging from 2 to 5 micron in size. The surface of fat globule is coated with membrane called as fat globule membrane. Chemically fat is composed of number of glyceride esters of fatty acid. The fatty acids are saturated and unsaturated. Milk fat is sweet in taste and imparts smoothness and palatability to milk and milk products. The pricing of milk depends on the fat content of milk.

Try this...

Take water and milk in separate vessel, boil them and observe the changes.



3. Protein : It is the complex organic substance present in colloidal state. The proteins of milk consists of casein, α -lacto albumin and β - lacto globulin. Casein is composed of calcium-caseinate - phosphate complex. It is precipitated by acid, rennet, alcohol, heat etc. Casein itself is composed of β , γ and κ casein. Lacto-globulin and lacto-albumin are whey proteins or serum proteins.

4. Lactose : It is called as milk sugar. It is $1/6^{\text{th}}$ as sweet as sucrose. Chemically, lactose is composed of one molecule each of glucose and galactose. It is fermented by bacteria to yield lactic acid which is organic acid and important for production of cultured milk products e.g. Dahi, Shrikhand, Lassi etc.

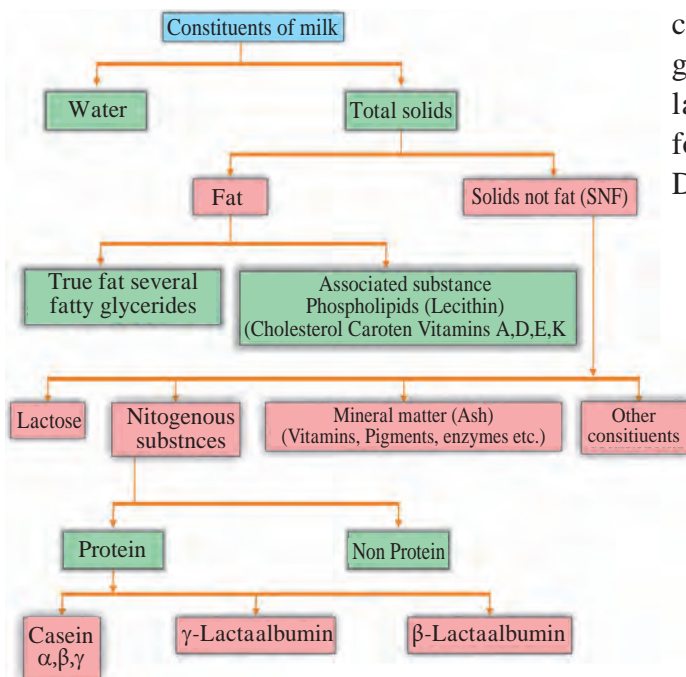

Fig. 9.2 : Milk constituents

Do you know ?

Milk is the only source of lactose



5. Ash or Mineral matter : It is available in trace amount. It influences physico-chemical properties and nutritive value of milk. The mineral constituents are potassium, sodium, magnesium, calcium, phosphorus, citrate, chlorides, sulphate and bicarbonates.

Internet my friend

Why children dislike milk ?



B. Minor milk constituents

1. Vitamins : Milk contains two types of vitamins -

a. Fat Soluble vitamins : e.g. A,D,E & K,

b. Water soluble vitamins : e.g. Thiamine (B_1), Riboflavin (B_2), Pantothenic acid, Niacin, Pyridoxine (B_6), Biotin, B_{12} , Folic acid etc.

Do you know ?

Milk is a poor source of vitamin C and iron (Fe) but a fair source of vitamin E.



2. Enzymes : The important milk enzymes are lipase-fat splitting, amylase-starch splitting, phosphatase-splitting phosphoric acid and esters, protease-protein splitting, peroxidase and catalase decomposes hydrogen peroxide .

3. Pigments : Milk contains two types of pigments

a. Fat soluble : e.g. carotene and xanthophylls

b. Water soluble : e.g. Riboflavin

Carotene, a precursor of vit. A impart yellow colour to cow milk, cream, butter and ghee. It also acts as an anti-oxidant.

4. Phospholipids : Phospholipids are of three types viz lecithin, cephalin and sphingomylin. They contribute to richness of flavour to milk and milk products. They are excellent emulsifying agents and thus stabilize milk fat emulsion.

Remember...

Phospholipids are responsible for rich flavour to milk.

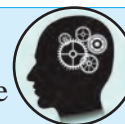

9.1.2 Properties of milk

Can you tell ?

- Why cow milk is yellowish in colour ?
- Why fresh milk is amphoteric in nature?



Physical properties of milk

1. Flavour : It is composed of smell and taste. The sweet flavour of milk is due to lactose and salty taste is because of minerals.

2. Colour : The cow milk is yellowish in colour due to presence of carotene whereas, the buffalo milk is purely white due to complete conversion of beta-carotene into Vit. A. The colour of milk is due to reflection of light by colloidal casein and dispersed fat globules.

3. Specific gravity : Milk is heavier than water. The specific gravity of cow and buffalo milk expressed at 15.6°C is 1.028 to 1.030 and 1.030 to 1.032, respectively. It is measured by lactometer.

Do you know ?

Milk is heavier than water.

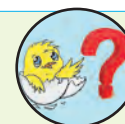

Try this...

Different lactometers available in the market



4. Freezing point : This is the temperature at which the liquid phase may freeze or crystallize and the solid phase may melt or liquefy. The freezing point of Indian cow milk is 0.549°C where as buffalo milk is 0.547°C

5. Boiling point : The average boiling point of cow and buffalo milk is 100.5°C .

6. Viscosity : The viscosity of the whole milk at 25°C is about 2.0 centipoises. The casein micelle and fat globules are the important for the viscosity of milk.

Chemical properties of milk

1. Acidity : Freshly drawn milk is amphoteric in reaction i.e. red litmus turn blue and vice versa. The Titrable Acidity (T.A.) is expressed as percent of lactic acid. The T.A. of cow milk is 0.13 to 0.14 % Lactic Acid and buffalo milk is 0.14 to 0.15% Lactic Acid (L.A.)

Remember...

Titrable acidity is also known as Natural or apparent acidity and is caused by the presence of casein, acid phosphate, citrates etc. in milk and developed acidity is due to lactic acid produced by bacteria

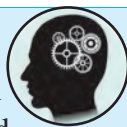

2. pH : The pH of normal, fresh, sweet milk usually varies from 6.4 to 6.6 for cow milk and 6.7 to 6.8 for buffalo milk. Higher pH values for fresh milk indicate udder infection (mastitis) and lower values suggest bacterial action. It is affected by contamination, ageing and temperature of stored milk.

9.1.3 Preservation of milk : The following are Three different methods of preservation of milk

1. Chemical preservation

Do you know ?

Preservatives are the chemical substances that are added to milk to check the growth of microorganisms and thus prevent spoilage of milk.



Preservatives are added to prolong the keeping quality of milk. They prevent spoilage of milk from bacterial action It is used only for testing of milk in laboratory and not useful for human consumption.

Remember...

The addition of preservatives in milk and milk products is not permitted in India. Hence, no preservative shall be added except in samples which are to be preserved for chemical analysis.

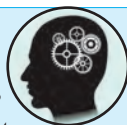

The various chemicals which are used as preservatives in milk are Boric acid and its salts (borates). Carbonates and bicarbonates, Formalin, Hydrogen peroxide, Benzoic acid, Salicylic acid and Niacin.

2. Pasteurization of milk

Pasteurization derives its name from French Scientist Louis Pasteur, who found that the heating of certain liquids especially wine at high temperature improved its keeping quality.



Louis Pasteur (1822 – 1895)

Louis Pasteur : Born on December 27, 1822, in Dole, France, Louis Pasteur discovered that microbes were responsible for souring alcohol and came up with the process of pasteurization, where bacteria are destroyed by heating beverages and then allowing them to cool.

Pasteurization is the process of heating a liquid to below the boiling point to destroy microorganisms. It was developed by **Louis Pasteur** in 1864 to improve the keeping qualities of wine. Commercial **pasteurization of milk** began in the late 1800s in Europe and in the early 1900s in the United States

Definition : The pasteurization, as applied to market milk, refers to the process of heating of every particle of milk to at least 63°C (145°F) and holding it at this temperature for at least 30 minutes or heating at 72°C (161°F) and holding it at this temperature for 15 seconds followed by immediate cooling to 5°C(41°F) or below.

Objectives:

1. To destroy all pathogenic and non-pathogenic microorganisms in milk & make it safe for human consumption

- To improve the keeping quality of milk by destroying most of the microorganism.

Methods of pasteurization of milk

1. Low temperature long time (LTLT) method:

This is also called as batch or holding method. It is the process in which milk is heated at 63°C (145°F) and held for minimum of 30 minutes followed by cooling to 5°C (41°F). This process is carried out in a double jacketed vat fitted with a mechanical agitator and a thermometer. An outlet is provided in the bottom portion of the vat to drain out the pasteurized milk. Heating of milk is done by circulating hot water or steam and cooling by chilled water.

This method is used at small scale dairy plants.

2. High temperature short time (HTST) method:

It is continuous process in which milk is heated to 72°C (161°F) for 15-16 seconds and cooled to 5°C.

The flow of milk in H.T.S.T. pasteurizer is as follows.

H.T.S.T. pasteurizer unit consists of following different sections. Pasteurizer comprises of stainless steel plates arranged in a series. The heating and cooling of milk takes place through these plates.

1. Float controlled balance tank : This regulates the supply of milk to the regeneration section of pasteurizer with the help of a centrifugal pump.

2. Regeneration section : The raw cold incoming milk is partially and indirectly heated to 51.6 to 54.4°C by the hot outgoing milk (milk to milk regeneration). This saves energy and adds to the economy of the HTST process, as the incoming milk requires less heating by hot water to raise its temperature for holding.

3. Filter : The units are connected directly to HTST system and which are placed after the pre-heater or regenerative (heating) section, these units, using 40-90 mesh cloth, are usually cylindrical in shape. Usually two filters are attached. Only one is used at a time. This permits continuous operation the flow being switched from one to the other while replacing of filter.

4. Heating section : Milk is heated to 72°C for 15-16 seconds with the help of a heating medium such as steam/hot water.

5. Holding section : Milk is held at 72°C for 15-16 seconds.

6. Cooling section : The pasteurized milk from the regeneration section is forced to the cooling section and cooled to 5°C, chilled water is used as cooling medium.

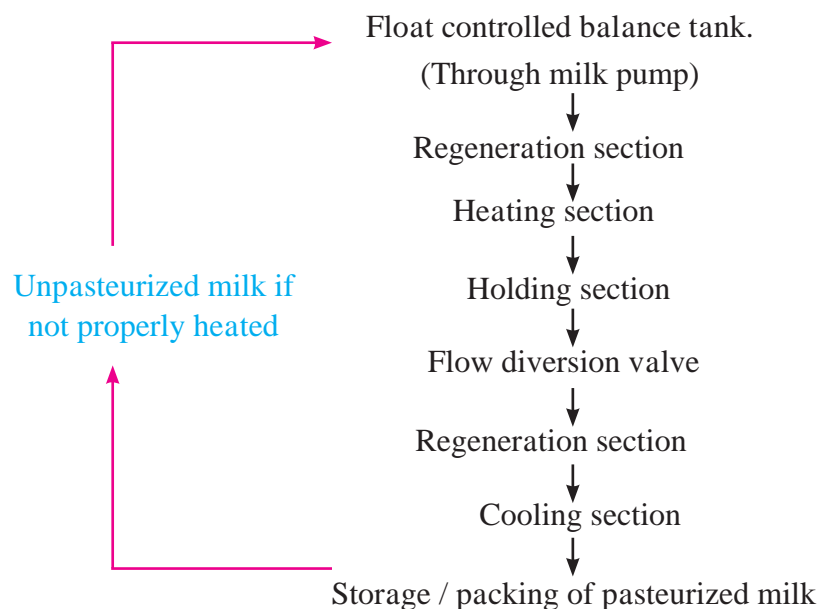

Fig. 9.3 : Flow diagram of HTST Pasteurization

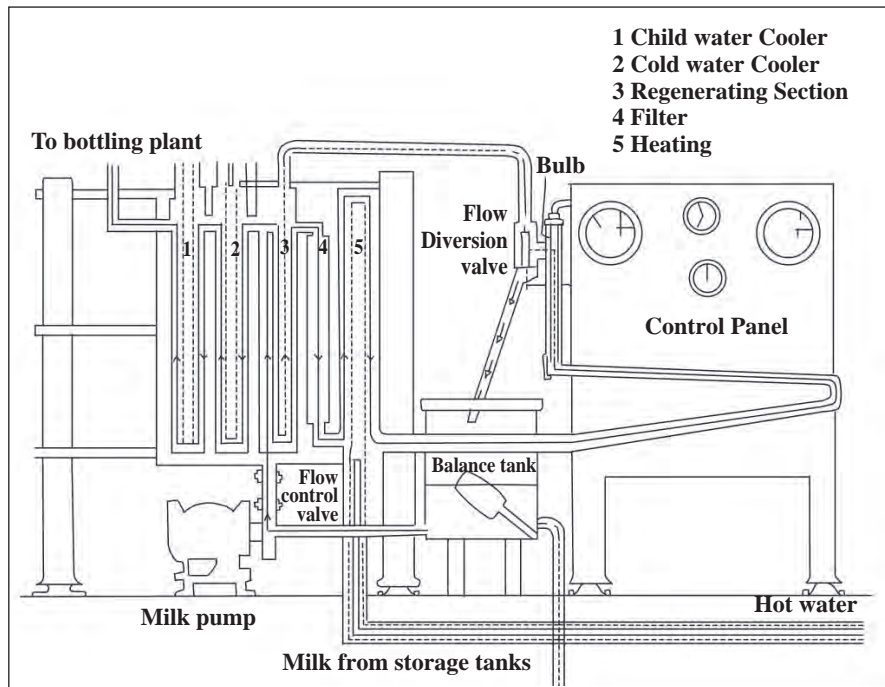

Fig. 9.4 : HTST pasteurizer

7. Flow diversion valve : The pasteurized milk is diverted to the regeneration section and improperly pasteurized milk (milk having temperature below 72°C is re-circulated to the balance tank for further pasteurization.

7. Development of thermophilic organisms is not a problem.
8. The process can be interrupted and quickly restarted.

Disadvantages

1. This is not beneficial for small amount of milk.
2. Gasket requires constant attention for possible damage.
3. Greater accumulation of milk stone in the heating section.
4. Complete drainage is not possible (without losses exceeding those from the holder system).

Try this...

Visit nearby dairy plant and observe the process of milk pasteurization.



Use your brain power

Differentiate LTLT and HTST method of milk pasteurization



Advantages

1. Capacity of heat treatment to milk is quick and adequate.
2. Less floor space is required.
3. It involves lower initial cost and operating cost.
4. Beneficial for large amount of milk.
5. Pasteurization capacity can be increased at nominal cost.
6. Reduced milk losses.

3. Chilling of milk

Try this...

- Visit nearest milk chilling center and study process of chilling.
- To know the importance of chilling.



The freshly drawn milk contains micro-organisms. Their number increases during subsequent handling especially under unsanitary conditions at village level. The common

milk micro-organisms grow best between 20-40°C. Bacterial growth is invariably related by deterioration in market quality due to development of off flavours, acidity etc. Freshly drawn raw milk should therefore be promptly cooled to 5 °C or below and also held at that temperature till processed. Chilling is very effective in checking the growth of micro-organisms present in milk. Cooling delays milk spoilage. Immediately after reception, milk is chilled.

Try this...

Different methods of chilling of milk



9.1.4 Packaging of milk

Packaging means placing a commodity in a protective wrapper or container for storage and transport with the ultimate purpose of delivering it to the user safely without deterioration in shape, size and quality.

As a result of socioeconomic changes, packaging has become increasingly important for establishing a particular brand. The different types of packaging and milk distribution system for fluid milk are as follows

- i. Returnable containers such as glass bottles.
- ii. Single service containers in sachets or cartons.
- iii. Dispensing through milk can or bulk vending machines directly into container.

Try this...

Observe the process of packaging of milk and milk products.



1. Packaging in bottles : Milk is packaged in plain glass bottles either manually or through mechanical bottle fillers. But packaging of milk in glass bottles requires extra expenditure on bringing the empty bottles back to the dairy plant for their re-use. This is the reason why bottle packaging is gradually being replaced by polythene packaging in the dairy industry.



Fig. 9.5 : Bottle packaging of milk

2. Packaging in single service containers : These containers have almost replaced bottle packaging because-

- 1. Empty containers need not to be returned, thus saving significant expenditure on transportation.
- 2. There is no need of cleaning of the empty containers.
- 3. Labour requirement is also less.

The containers are tamper proof. Single service containers are of two types.

a. Pre-fabricated packs : These are generally made up of cardboard coated with wax. The filler used for filling these cartons is similar to the gravity filler bottles.

b. Form and fill cartons / Pouches : The machines are fully automatic. The units form, fill and seal milk pouches in a continuous operation out of the rolls LDPE (Low density polyethylene) film. These machines are available in varying capacities and can pack milk in 200ml, 500 ml or 1 lit. pouches.



Fig. 9.6 : Milk pouch

Can you tell ?

Why packaging bottles are replaced by milk pouch for packaging of milk.



3. Packaging in cans : Stainless steel, aluminum or plastic cans of 20 or 40 liters capacity are cleaned and sanitized properly. Pasteurized milk of the desired standard is filled through a filling unit using appropriate lines and valves. The cans are sealed, marked and shifted to a cold room for storage till distribution.



Fig. 9.7 : Milk can (Aluminum and steel)

Milk packing machine : Now a day's fully automatic milk packaging machines are available in the market designed for packaging of milk in LDPE film, commonly known as "Milk pouch packing machine". The film roll is mounted on backside of milk packing machines, after unwinding mechanism film passes through series of free roller.



Fig. 9.8 : Milk pouch packing machine

9.1.5 Storage of milk

Modern milk plants hold both raw and pasteurized milk for a much longer period than earlier storage methods. Normally the milk storage capacity is equal to one day milk procurement.

Storage tanks are used in milk plants for the storage of raw, pasteurized or processed products. They must be designed for ease in sanitization, preferably by the circulation-cleaning method. In addition, the tanks should be insulated or refrigerated. So that they can maintain the required temperature throughout the holding period.

Try this...

Observe the storage rooms of modern dairy plant.



Can you tell ?

The importance of storage of milk and milk products



Objectives of storage

- To maintain milk at a low temperature so as to prevent any deterioration in quality prior to processing / product manufacture.
- To facilitate bulking of the raw milk supply, this will ensure uniform composition.
- To allow for uninterrupted operation during processing and bottling.
- To facilitate standardization of the milk.

Types of storage tank : Milk storage tanks are as follows.

1. Insulated and refrigerated tanks

The storage tanks are either insulated or refrigerated.

a. Insulated tanks : These tanks basically consist of stainless steel, a layer of insulating material viz thermocool /glasswool /cork /fiber glass and outer casing of stainless steel/ alloy aluminium or mild steel with necessary fittings for inspection, control and cleaning.

b. Refrigerated tanks : They have refrigerating facilities so that stored milk is chilled as and when required. In refrigerated tanks, the hollow space between the inner and outer shells is used for circulation of the cooling medium. Generally chilled water or brine solution is used as cooling medium.

2. Horizontal and vertical tanks

a. Horizontal tanks : They require more floor space than vertical ones but require less head space. The standard horizontal tanks are normally manufactured in 5000, 10,000 and 15,000 litre capacity.

b. Vertical tanks : They require less floor space but more head space. The standard vertical tanks are manufactured in 2000, 5000, 10,000 and 15,000 litre capacity. Silo tanks are used for bulk storage of milk having 1 lakh litre capacity.

3. Rectangular and cylindrical tanks

a. Rectangular tanks : They require more floor space than cylindrical. These tanks are difficult to clean because agitation effect does not reach the extreme corners of rectangular tanks.

b. Cylindrical tanks : They require less floor space than rectangular tanks. These tanks are easy to clean hence more preferred than rectangular tanks.

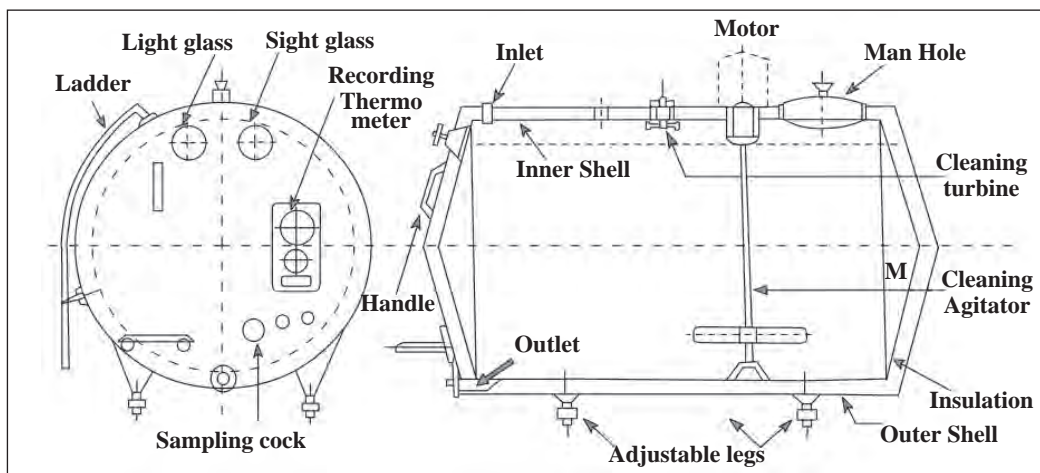

Fig. 9.9 : Horizontal type milk storage tank

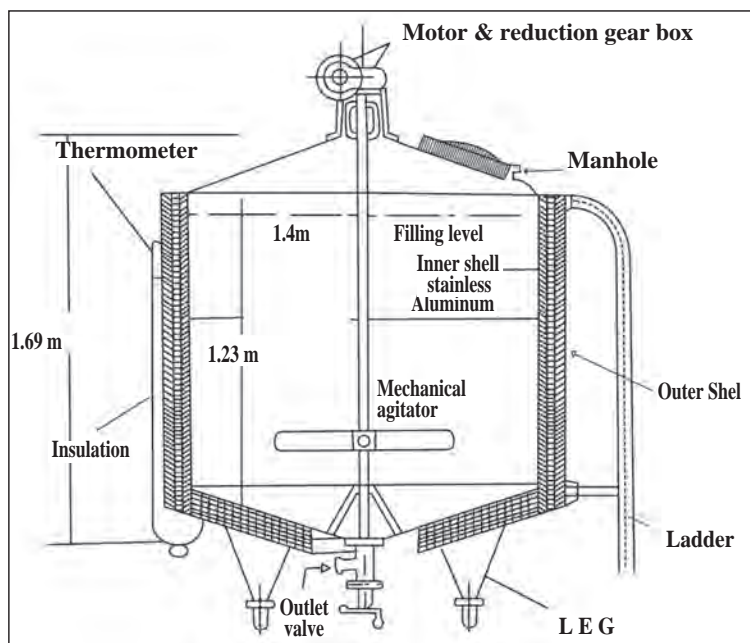

Fig. 9.10 : Vertical type milk storage tank

9.1.6 Transportation

Milk is a perishable commodity so it has to be regularly collected and transported twice a day (i.e. morning & evening). Hence transportation has a great importance.

The problems in relation to collection and transportation of milk are

1. Milk is liquid, perishable and bulky.
2. Small and scattered production of milk.
3. Tropical climate.
4. Lack of transport facilities.
5. Lack of country wide organizations for milk collection and transport.

Try this...

Observe and note how the milk is transported from rural to urban area.



9.1.7 Clean milk production

The concept of clean milk production is to develop sustainable, scientific and eco-friendly dairy animal management based on principles of clean, green and ethical practices. Clean milk is generally defined as “milk drawn from the udder of healthy animals, which is collected in clean dry milking pails and free from extraneous matters like dust, dirt, flies, manure etc”. Clean milk has a normal composition, possesses a natural milk flavour with low bacterial count and is safe for human consumption.

Steps for clean milk production

1. Milking shed should be cleaned with disinfectants before and after milking.
2. Wash the udder and teats with lukewarm potassium permanganate solution and wipe with clean towel.
3. Use strip cup method for screening the mastitis (udder infection), in this method milk of all four quarters will be stripped into a cup covered with black cloth. If the animal is suffering from mastitis, flakes of milk will be seen on black cloth.

4. If mastitis is detected, do not mix the milk of that animal in milk of healthy animals, the affected milk shall be totally discarded.
5. Drain the milk till the last strip as it contains more fat.
6. Immediately after milking, dip the teats in cup containing disinfectants to prevent infection.
7. Milker should be free from any infectious diseases. Should cut his nails regularly, wash his hands and legs before milking and should wear cap on the head.
8. He should not wet his hands with water or milk or saliva etc. during milking.
9. Practice “full hand” method of milking only. Avoid folding of thumb while milking. It may injure teats and cause wounds on teats.
10. Always use clean stainless steel or aluminum milk cans.
11. Milking cans should be thoroughly washed with detergent and should be sun dried every day.
12. Filter the fresh milk using clean dry muslin cloth.

Try this...

Visit to a organized dairy farm to observe machine milking and clean milk production



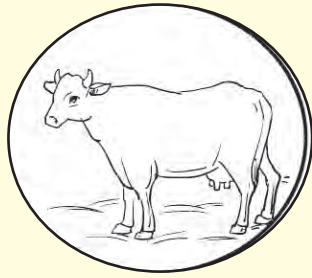

1. Clean and healthy cow

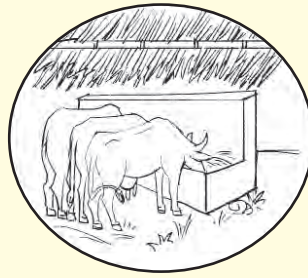

2. Clean byre for cows

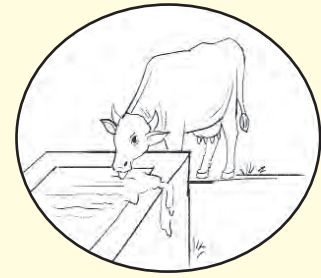

3. Clean water for drinking



4. Clean stainless-steel utensils



5. Clean hand washing before milking



6. Wipe the udder with clean cloth before milking



7. Remove the first one or two strips of milk



8. The milker is healthy and hygienic



9. At the time of milking give green forages to milch animal



10. Dipping of teat in germicides



11. Cover Milk cans and transport milk quickly to milk chilling centre

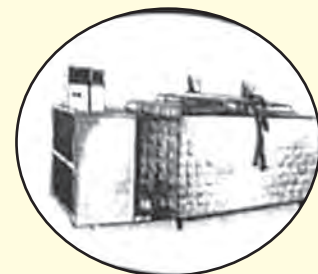

12. Store clean milk in refrigerator

Fig. 9.11 : Clean milk production steps

9.1.8 Organic milk



Fig. 9.12 : Organic milk

“Organic milk is milk produced from livestock raised according to organic farming methods and cows or buffaloes that are not treated with antibiotics”.

Features of organic milk

- Free from growth hormones.
- Free from any antibiotics
- No de-wormer or other preventive medicines are used
- Feed should be free from animal by-products.
- Feed should be free from artificial “roughage”.

Internet my friend

Search information on A1 and A2 type of milk



9.1.9 Adulteration of milk

Indians are habitual of drinking milk with water, which not only reduces its nutritive value of beverage but also possess risk to health.

A glass (250 ml) of unadulterated cow milk gives around 146 kcal, 11.5 gm of fat and 8.5 gm protein, 12.3 gm lactose with 257 mg of calcium and other vitamins and minerals, make it an important part of a balanced diet for people of all ages.

The addition of anything without clearly stating that addition on the label of the container is termed as adulterant.

Adulterants used in milk and milk products

Milk is adulterated with water, starch, gelatin, cane sugar, saccharin, glucose or monosaccharides, sodium chloride, urea, formalin, hydrogen peroxide etc. In ghee common adulterants used are vanaspati (dalda), refined vegetable oils e.g. Groundnut, coconut, cottonseed oil, animal fats etc..

In butter common adulterants used are animal fat and different oils, potato pulp starch, jaggary, soft paraffins vegetable oil, hydrogenated fat and margarine.

Hazards of Adulterants in Human Health

The Indian Council of Medical Research (ICMR) has reported that milk adulterants have hazardous effects on human health. The detergent in milk causes food poisoning and other gastrointestinal complications. Its high alkaline level can also damage body tissue and destroy proteins. Other adulterants like urea, caustic soda and formalin cause gastro enteritis and the long term effects are more serious.

Urea can lead to vomiting, nausea and gastritis. It is particularly harmful for the kidneys and caustic soda can be dangerous for people suffering from hypertension and heart problems. It harms the mucosa of the food pipe in kids. The chemical which contains sodium can act as slow poison for those suffering from hypertension and heart ailments.

9.2 Meat

Meat is defined as “All parts of animal that are intended for, or have been judged as safe and suitable for human consumption”. The most common sources of meat are domesticated animal species such as cattle, buffalo, sheep, goat, pig and poultry. These species are main sources of animal protein for human. Pork is the most widely eaten meat in the world accounting for over 36 % world’s meat intake followed by poultry 35 % and beef 22 %. Meat is composed of water, protein, fats, mineral, vitamins and other bioactive components, and small quantity of carbohydrates. From the nutritive point of view meat’s importance is derived from its high

quality protein, containing all essential amino acids and its highly bioavailable minerals and vitamins. Meat is rich in vitamin B₁₂.

Terms used for Meat....

- **Beef** : The flesh of a cow, bull or ox used as food
- **Carabeef** : The flesh of buffalo
- **Mutton**: The flesh of fully grown sheep used as food
- **Chevon** : The meat of adult goat used as food.
- **Chicken** : The meat of poultry
- **Pork** : Flesh of a pig used as food

Meat is animal flesh and worldwide eaten as a food. Many types of meat are used for Indian cooking, but chicken and mutton tend to be the most commonly consumed meats. Fish and beef consumption are prevalent in some parts of India, but they are not widely consumed except for coastal areas, as well as the north east.

The area which deals with the processing, handling, marketing and preparation of egg and meat products and by products is called as meat and egg products technology.

Do you know ?

Meat of cattle and buffalo is called as “Beef”, meat of goat is called as “Chevon” while meat of poultry is called as “Chicken”



9.2.1 Nutritive value of meat



Fig. 9.13 : Chicken



Fig. 9.14 : Mutton

Meat has high nutritive value having an excellent source of many nutrients, especially Protein, Iron, Vitamin B, Phosphorus and Zinc. Liver and other organs are also high in vitamin A, vitamin B₁₂, iron and selenium. Meat is also an excellent source of choline, an important nutrient for brain, muscle, and liver health. Meat contains all the essential amino acids. The composition of different type of meat, milk and eggs is as presented in table No.9.2

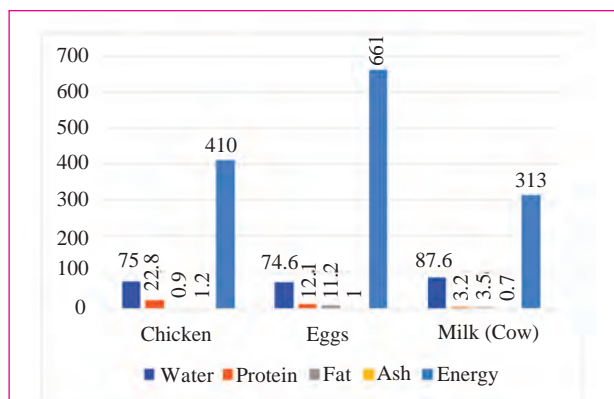

Fig. 9.15 : Composition of different meats

Table 9.2 : Composition of different types of meat, eggs and milk per 100g

S r . No.	Species	Water	Protein	Fat	Ash	KJ (Energy)
1.	Beef (lean)	75.0	22.3	1.8	1.2	485
2.	Goat (chevon)	76.0	22.3	2.6	1.1	580
3.	Sheep (mutton)	75.0	19.0	2.5	0.65	258
4.	Pork (lean)	75.1	22.8	1.2	1.0	469
5.	Chicken	75.0	22.8	0.9	1.2	410
6.	Egg	74.6	12.1	11.2	1.0	661
7.	Milk (cow)	87.6	3.2	3.5	0.7	313

Source: FAO, 2007

9.2.2 Processing of Meat and Meat Products

Basic meat plant operation such as cutting, trimming, deboning and grinding do not constitute meat processing. In fact processing refers to any treatment including salting which brings about a substantial chemical and physical change in the natural state of meat. It imparts considerable shelf stability to meat.

Basic processing procedure

1. Comminution - All processed meat can be classified as either non- comminuted or comminuted products. Non comminuted products are generally processed from intact cuts. These products are usually cured, smoked and cooked e.g. ham and bacon. The term comminuted meat is used to describe meat, either raw or pre-cooked, which has been cut, shredded, ground or minced into small pieces,

Remember...

Comminution refers to subdivision or reduction of raw meat into meat pieces or particles. Meat particle size reduction helps in the uniform distribution of seasonings and eliminates the toughness associated with meat of old animals and lowers the fuel for cooking.

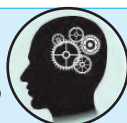

and a dispersed or discontinuous phase. For preparation of good meat emulsion lean meat is first chopped with salt to extract salt soluble protein and then fat and other ingredients are added. Once a good meat emulsion is formed it has to be protected during cooking or heat treatment.

Remember...

Meat emulsion comprises of a dispersed phase of solid or liquid fat droplets and continuous phase of water containing salt and protein for practical purposes Meat emulsion is an oil- in -water emulsion where solubilised meat protein act as emulsifier.



3. Meat extension : Soy products, potato starch and flour of wheat, rice, pea, corn, etc. are used as fillers to reduce cost of formulations. Several milk products such as skim milk powder, dried whey, sodium caseinate, etc. are frequently used as binders. Some gums like sodium alginate, carrageenan, gum Arabic, etc. may be used to stabilize fragile meat emulsion.

2. Emulsification – A mixture of two immiscible liquids where one liquid is dispersed as droplets in another liquid is called emulsion. An emulsion has two phases a continuous phase

Remember...



Non meat food items which are incorporated in meat products are generally termed as extenders although these may be referred as fillers, binders, emulsifiers or stabilizers depending on the purpose and their incorporation in the basic meat formulation.

4. Preblending : It refers to the mixing of a part or all the curing ingredients (salt, nitrite, nitrate, etc.) with a ground meat in specified proportions. This process allows better extraction of protein which in turn helps in formation of stable emulsion. It permits control of product composition by adjusting the desired fat content.

5. Hot processing : It refers to the processing of carcass as soon as possible after slaughter (Certainly within 1-2 hours) without undergoing any chilling.

Advantages

- i. Accelerate the processing step and entire processing time is reduced
- ii. Improvement in the cooking yield and sensory quality of the product.

6. Cooking : Meat and meat products are cooked by one or a combination of three methods-dry heat, moist heat and micro wave cooking. Dry heat cooking is used for tender cuts of meat such as pork chops, legs and chops of lamb, ground and comminuted meats, etc. Dry heat cooking involves either broiling, roasting or frying in broiling. Meat held on a wire grill is exposed to heat from above as in electric and gas oven. Or below as in charcoal broiler. Meat is required to be turned for uniform and sufficient cooking of all sides. Roasting is also practiced on tender cuts of meat. Cooking temperature and time varies according to the cut. Roasting generally gives a good browning and improves the flavour of the product. Frying dep fat or shallow pan is also classified under dry heat cooking. This meat is suitable for thin cuts of meat such as sliced steaks, mutton chops, chicken meat pieces, etc.

Moist heat cooking is recommended for relatively tough cuts of meat. In this method hot water or steam is continuously kept in contact with meat for cooking so that moisture loss does not take beyond a particular stage. Pressure cooking, stewing, simmering, etc. are popular moist cooking procedures.

Microwaves are high frequency non-ionizing electromagnetic waves which are generated by magnetron vacuum tube within the oven.

Microwave penetrates the food from all direction simultaneously upto a depth of 2-4 cm causing water, fat and sugar molecules to vibrate at a very high speed. The vibrations cause tremendous friction which produces heat for cooking the food.

7. Sausages : Presently sausage may be defined as meat product which is prepared from minced and seasoned meat and formed into cylindrical shape by natural or synthetic casings.

Remember...

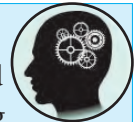

Sausages term was derived from the latin word 'Salsus' meaning salt. It was coined to refer the ground meat which was salted and stuffed in animal casings

7.1 Classification

Sausages are a large number of varying kinds of products that it is not possible to cover them in any classification system. Some of the popular classification systems are

Sausages

1. Based on degree of chopping : Coarse ground sausages Emulsion type sausages

2. Based on moisture content :

Fresh sausage Smoked uncooked sausage
Cooked Sausage Dry and semi dry sausage

3. Based on fermentation : Fermented sausage Non fermented sausage

Processing steps

1. **Grinding or mincing** : Lean meat and fat are minced separately in a meat mincer. The choice of mincer plate or sieve depends on the type of meat.
2. **Mixing** : Meat and fat to be used for the preparation of coarse ground sausage are mixed uniformly in a mixer. Extender, condiments and spices should also be run in the mixer for even distribution.
3. **Chopping and emulsifying** : For emulsion preparation lean meat is first chopped for few minutes in a bowl chopper with salt to extract myofibrillar protein which is followed by addition of fat and running for a few minutes again to get desired emulsion consistency. Now all other ingredients are added and chopper is run for some time for uniform distribution. The entire operation is conducted at low temperature by addition of ice flakes in place of chilled water.
4. **Stuffing** : Sausage emulsion or batter is taken to stuffer for extrusion into casings. The casings are first collected on the stuffing horn or nozzle and released to coincide with the extrusion.
5. **Linking and tying** : In small sausages the encased mass is twisted to produce links either manually or mechanically. Whereas in large sausages the encased mass is tied with the thread at regular interval.
6. **Smoking and cooking** : Sausage links are hung on the smoke house and trolley and transferred to smoke house. The temperature of smoke house is usually maintain at 68-70°C which is enough for coagulation of sausages emulsion, cooking and requisite drying of sausages.
7. **Chilling** : The cooked product is showered with chilled water to an internal temperature of about 4°C.
8. **Peeling and packing** : While artificial or synthetic casings are peeled off before

the product is packed. Small sized natural casings need to be removed. The product is generally unit packed for retail outlets.

9.2.3 Preservation of meat

The primary objective is to inhibit microbial spoilage and arrest physio-chemical process which brings about deterioration in quality. Methods used for preservation are as follows

1. Refrigeration : Meat can be stored at 1⁰ to 4⁰C with relative humidity of 80-85% for about a week. Crushed ice or mechanical refrigeration are generally used for chilling or cold storage.

2. Freezing : Meat can be frozen in air or liquid or refrigerated plates. Ideally, only chilled carcasses should be frozen.

a. Slow freezing : Still air, the method generally used in home freezer or small freezing operation.

b. Quick freezing : Air blast system used in commercial operation. Meat stored at -20⁰C for 12, 15, 18 months with excellent, good and satisfactory quality, respectively.

3. Curing and smoking : These are closely interrelated and often practiced together. Curing is the process of salting meat along with one or more of the glutamates, ascorbic acid, acetic acid and phosphate. Cured chicken are smoked in a smoke chamber maintained at 40- 45⁰C and 30-35% relative humidity for about 4 hours. The smoking process imparts a characteristic flavour and stable colour to the cured product and helps in preservation. Cured chicken could be stored for 4 and 14 days at ambient (26⁰C) and refrigeration (4-5⁰C) temperature, respectively while cured and smoked chicken for 14 and 30 days under the corresponding storage conditions.

4. Dehydration : Conventional hot air, drum, spray and freeze drying are the methods used to remove moisture from poultry meat. Generally, cooked meat is dehydrated. Dehydrated product is a porous mass with original shape and size which can remain stable up to 1 year under ambient condition when packed in tins under nitrogen.

5. Canning : It is heat processing of meat in airtight sealed containers.

6. Use of antibiotics : Antibiotics can be used for the preservation of raw meat but not in processed products.

7. Radiation preservation : It is also known as cold sterilization. The radiant energy is used to destroy the micro-organisms and inactivation of enzymes without any rise in the temperature of foods.

9.3 Eggs

The most commonly consumed eggs are chicken eggs. Other poultry eggs including those of duck and quail also are eaten. Fish eggs are called roe and caviar. Egg yolks and whole eggs contain significant amounts of protein and choline, and are widely used in human diet.

Do you know ?

Fish eggs are called Roe and Caviar



Eggs are among the most nutritious foods. A whole egg contains all the nutrients required to turn a single cell into a baby chicken. Eggs also contain good amounts of vitamin D, vitamin E, vitamin K, vitamin B6, calcium and zinc.

9.3.1 Nutritive value of poultry egg

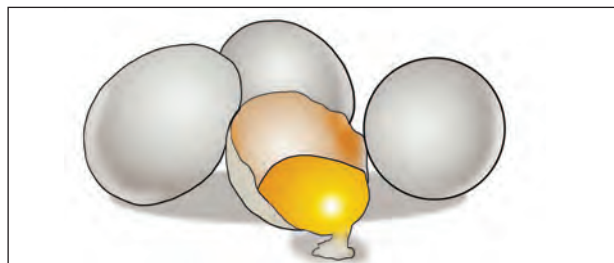

Fig. 9.16 : Poultry Eggs

Poultry eggs have very good nutritive value. The high nutrient content, low calorific value and easy digestibility make it a valuable protective food in human diet. The average chemical composition of edible part of hen's egg and role of eggs in daily diet are presented in Table 9.5 and 9.6.

Use your brain power

Is egg veg or non-veg ?

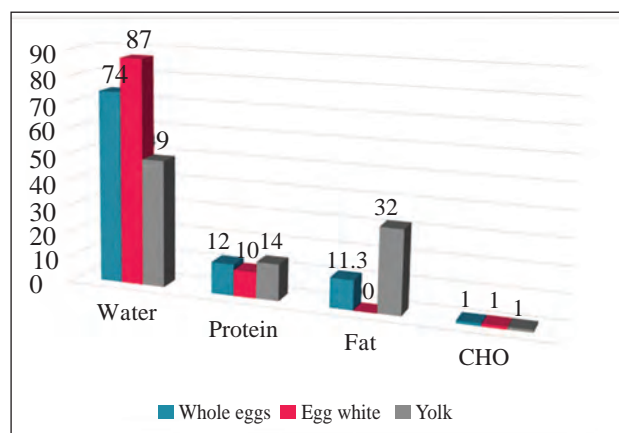

Fig. 9.17 : Composition of poultry eggs

Table 9.3 : Average chemical composition of edible part of poultry egg (%)

Sr. No.	Particular	Whole Eggs	Egg white	Yolk
1	Water	74.0	87.0	49.0
2	Proteins	12.0	10.0	14.0
3	Fat	11.3	Nil	32.0
4	Carbohydrates	1.0	1.0	1.0

Table 9.4 : Role of eggs in daily diet

Sr. No	Nutrients	Recommended daily allowance for a moderately active man	Quantity in eggs	Per cent daily requirement supplied by 1 egg
1	Energy (cal)	3000	90	03
2	Proteins (g)	70	6.6	10
3	Fat (g)	50	5.5	11
4	Calcium (g)	0.8	0.03	4
5	Phosphorus (g)	0.9	0.12	14
6	Iron (mg)	12	1.6	13
7	Iodine (mg)	0.1	0.005	05
8	Vitamin A (IU)	5000	500	10
9	Vitamin D (IU)	400	50	13
10	Vitamin B ⁻¹ (mg)	1.5	0.06	4
11	Vitamin B ² (mg)	2	0.16	8
12	Niacin (mg)	20	0.6	3

9.3.2 Designer eggs



Fig. 9.18 : Designer eggs



Fig. 9.19 : Normal eggs

In order to meet the growing demand of health conscious consumers, nutrient content of the normal eggs can be modified to provide nutrients above and beyond what normally found in the normal eggs are called as designer eggs.

“Designer eggs are those specially produced eggs which are rich in additional nutrients and health promoting components like carotenoids, trace minerals, EPA and DHA like omega 3 fatty acids”.

Do you know ?

Designer eggs prevent cancer causing factors, cardiovascular diseases (CVD) and improve immunity and overall health status.



Production of Designer eggs

Designer eggs are produced by feeding special feed to chickens with sea kelp, flax seed and canola oil or other types of non-animal fats. Hens raised on this special diet will produce eggs with lower saturated fat that are fortified

with omega 3 fatty acids, iodine, selenium and vitamin E.

Remember...

Designer eggs are also known as “Supplemented eggs”

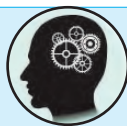

9.3.3 Grading of eggs

Try this...

Visit the local egg market and grade the eggs.



Grading is the classification of eggs into different categories. It helps in reducing wastage and facilitates uniform packaging, pricing and quality assurance to the consumers.

Egg grading involves inspection of

- i. Egg weight
- ii. Shell cleanliness and soundness
- iii. Internal quality
 - a. Size of air cell
 - b. Firmness of albumen
 - c. Position of yolk
 - d. Blood and meat spots

Egg can individually flash candled to detect the above defects. The standards for table eggs are given in Table 9.8.

9.3.4 Preservation of eggs

Eggs are preserved as a shell eggs or liquid eggs.

A. Shell eggs

The methods for preservation of egg shell are based on simple principle of retarding the microbial growth and sealing the pores of the shell to minimize the evaporation of moisture and escape of gases.

Following methods are employed for effective preservation -

1. Thermal processing, 2. Immersion in liquids, 3. Oil coating and 4. Cold storage

1. Thermal processing

This includes heat treatment, thermo-stabilization and simultaneous coating and thermo-stabilization.

- i. **Heat treatment :** Eggs are immersed for 2 to 3 seconds in water at 71°C temperature. It destroys bacteria present on the surface of shell besides coagulating a thin film of albumen immediately beneath the shell membranes and thus seal the shell internally.

Table 9.5 : Grade designation and quality of table eggs produced in India

Sr. No	Grade	Weight per egg (g)	Shell	Air cell	White	Yolk
Grade “A”						
1	Extra large	60 & above	Clean unbroken & sound. Shape normal	Upto 4 mm in depth, particularly regular or better	Clear, reasonably firm	Fairly well centred practically free from defect. Outline indistinct
2	Large	53-59				
3	Medium	45-52				
4	Small	38-44				
Grade “B”						
1	Extra large	60 & above	Clean to moderately stained & sound. Shape slightly abnormal	8 mm in depth, may be free & slightly bubbly	Clear, may be slightly weak	May be slightly off centred out line slightly visible
2	Large	53-59				
3	Medium	45-52				
4	Small	38-44				

Source - Indian Poultry Industry, Year book 1990, 9th Edn.

ii. **Thermo-stabilization** : Eggs are immersed in water at various temperature.

49°C for 35 minutes

OR

54°C for 15 minutes

OR

56°C for 10 minutes

OR

60°C for 5 minutes

Heat stabilizes the thick albumen so that such egg remains fresh much longer than unheated eggs.

iii. **Simultaneous oil coating and thermo-stabilization** : These two processes complement each other in maintaining the internal quality of eggs.

2. Immersion in liquids

Under village conditions two liquids are used

i. Lime water and ii. Water glass.

i. **Lime water** : The preservative effect of the lime water is partly due to its alkalinity. It deposits a thin film of calcium carbonate on the egg shell and thus partially seals the pores. The stepwise procedure is as follows.

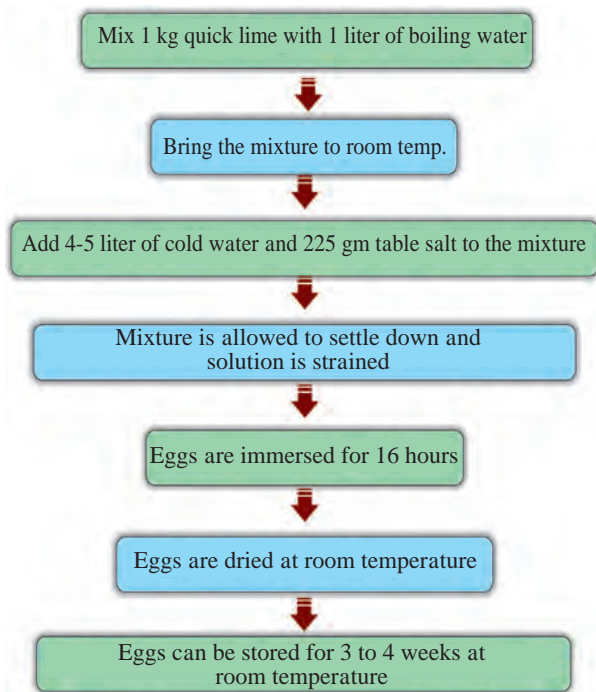

Fig. 9.20 : Preservation of egg

ii. **Water glass** : Dilute 1 part of sodium silicate with 10 parts of water, and the eggs are left immersed overnight in water glass. It deposits a thin precipitate of silica on the surface of egg shell.

3. Oil coating

Oil treatment preserves the eggs by forming a thin film on the surface of shell and thereby sealing the pores. The treatment should preferably be given within a few hours of lay to retain better internal quality. The vegetable oil used must be colourless, odourless, less viscous and free from fluorescent material.

4. Cold storage

For short period of storage, fresh eggs could be stored at 12.5 to 15.5°C and 70-80% relative humidity. For long term storage, the storage temperature should be at 10°C and 80-90% relative humidity. Eggs can be oil treated prior to cold storage to enhance their keeping quality. It can be done with eggs of small size like quail eggs.

Do you know ?

Egg can be stored at 12.5 to 15.5°C with 70 – 80 % relative humidity, 10°C with 80 – 90 % relative humidity for short and long period, respectively.



B. Liquid Eggs

Two methods are commonly used for the preservation of liquid whole egg, albumen and yolk separately, depending on their use.

i. Dehydration and ii. Freezing.

i. **Dehydration** : This method is used for preparation of whole egg powder. In this method moisture content of egg is reduced to 4-5%. Egg powder is packed in airtight sealed containers under nitrogen and it can be stored for more than 6 month at ambient temperature.

ii. **Freezing** : Rapid freezing is accomplished in an air blast at -1.1°C, and the frozen whole egg, albumen and yolk should be stored at -32°C or below.

9.3.5 Transportation of meat and eggs

Modes of transportation

Transportation of dressed carcasses for short distance, insulated containers of suitable thermal efficiency provided with adequate refrigeration can be used. For long distance transport specially built vehicle with refrigeration equipment is used. The temperature of ordinary vehicle can be controlled by solid carbon-dioxide containers attached to the roof of that vehicle.

Care during transportation

- Care is to be taken to prevent surface contamination and the job to be done under hygienic conditions.
 - Placing the dressed carcass in a film envelope which is then sealed.
 - Wrapping the carcass in sheets of grease proof paper big enough to cover it completely.
- As far as possible, temperature changes in the carcasses should be avoided during transport. The aim being to ensure that all carcasses travel at temperature below 50°F.

- Vehicle used for transport of dressed carcasses should be clean. Vehicle should be well equipped with hot, cold water, hose pipes, detergents, buckets, brass brooms etc.

A high degree of cleanliness should be maintained by all persons engaged in the handling and transport of poultry products.

Eggs transport



Fig. 9.21 : Transportation of eggs

Shell eggs packed for consumers be stored and transported under refrigeration at an air temperature not to be exceed 45°F.

All packed shell eggs be labeled with a statement that refrigerations is required.

Exercises

Q. 1 Fill in the blanks

- is the important constituent of milk for deciding the price of milk.
- is a whole, fresh clean and normal lacteal secretion of healthymich animal after 5 days and before 15 days of parturition.
- are the chemical substances that are added milk to check the growth of Micro-organisms and thus prevent spoilage of milk.
- is the continuous method of pasteurization.
- Titrateable acidity of cow milk is ----- % lactic acid

Q. 2 Make the pairs.

Group A

- Lactose
- Carotene
- L.T.L.T
- Canning

Group B

- Heat processing of meat.
- Batch pasteurization
- Pigments.
- Milk sugar
- Sucrose

Q. 3 Write true or false

- Milk is sweet in taste, yellowish white in color and heavier than water.
- Chilling is the important process to destroy all pathogenic organisms in milk.

3. Meat of goat is called as chevon.
4. Poultry eggs have very good nutritive value.
5. H.T.S.T. method of pasteurization in which milk is heated to 72°C(161°F) for 15-16 seconds and cooled to 50°C.

Q. 4 Identify odd one

1. Milk, Beef, Chevon, Chicken
2. Cow, Buffalo, Goat, Dog
3. Pasteurizer, Cooler, Homogenizer, stabilizer
4. Fat, Protein, vitamins, Lecithin

Q. 5 Answer in brief.

1. Give two objectives of pasteurization.
2. What are the preservatives?
3. What do you mean by fat soluble vitamins and give two examples.
4. Why the milk is called as complete food?
5. Give the importance of chilling.
6. Enlist the method of pasteurization of milk.
7. Write any two preservatives used for milk preservation.
8. Define organic milk and enlist any two features of it.
9. What do you mean by designer eggs?

Q. 6 Answer the following questions

1. Give nutritive value of poultry eggs.
2. Give chemical composition of poultry eggs.

3. Why kadaknath meat is so popular.
4. Write the objectives of storage of milk.
5. Give various methods of packaging of milk.
6. Give advantages of HTST pasteurization.
7. Write in short about horizontal type of milk silos.

Q. 7 Answer the following questions.

1. Write about grading of eggs.
2. Give the information about preservation of eggs.
3. Write in short about transportation of poultry products.
4. Write the steps for clean milk production.
5. Write in short about lime water treatment for preservation of milk.
6. Write about constituents of milks.

Q. 8 Answer the following questions in details.

1. Define pasteurization and explain HTST pasteurization in detail.
2. Write in detail about the preservation of meat.
3. Enumerate and explain the properties of milk.
4. Write about preservation of liquid eggs.

