

ANSWERS

CHAPTER 1

Exercise 1.1

- 1) $Q_1 = 10.9, Q_2 = 12, Q_3 = 14$
- 2) $Q_1 = 150.25, Q_3 = 165$
- 3) $Q_1 = 191$
- 4) $Q_3 = 650$
- 5) $Q_1 = 2, Q_2 = 3, Q_3 = 4$
- 6) $Q_2 = 165$
- 7) 12, 13
- 8) $Q_1 = 10500, Q_2 = 11500, Q_3 = 12500$
 $Q_1 < Q_2 < Q_3$
- 9) $(Q_1, Q_3) = (225, 585)$
- 10) 81

Exercise 1.2

- 1) $D_6 = 69.2, P_{85} = 80.05$
- 2) $D_8 = 379, P_{90} = 420$
- 3) $D_2 = 120, P_{65} = 280$
- 4) $P_{15} = 11000, P_{65} = 15000, P_{92} = 16000$
- 5) a) 30% b) 42%
- 6) $D_4 = 13, P_{48} = 14.6$
- 7) $D_9 = 98, P_{20} = 66.85$
- 8) 18, 20
- 9) $(P_{20}, P_{80}) = (1625, 4400)$
- 10) 24.72%

Exercise 1.3

- 1) $Q_1 = 26, D_6 = 32.5, P_{85} = 40$
- 2) $Q_1 = 150, Q_2 = 228, Q_3 = 298$
- 3) $Q_2 = 574$

- 4) (i) $(D_3, D_7) = (20, 36, 5)$, (ii) 67
- 5) $Q_2 = 19, D_2 = 13, P_{65} = 21.2$
- 6) $D_1 = 22, Q_1 = 30.5, P_{40} = 37$
- 7) $D_3 = 44, D_5 = 55.5, D_8 = 68$
- 8) $Q_2 = 17.5$
- 9) $(Q_1, Q_3) = (1025, 1248)$
- 10) $D_3 = 79.5, P_{65} = 93.5$

MISCELLANEOUS EXERCISE - 1

- 1) $P_{17} = 2, Q_2 = 3, D_7 = 4$
- 2) $Q_2 = 5, D_1 = 2, P_{95} = 8$
- 3) Mathematics $(Q_2) = 33.5$,
Statistics $(Q_2) = 30.5$,
Knowledge of Mathematics is higher than
Statistics.
- 4) 25
- 5) $Q_1 = 128.125, D_6 = 213.33, P_{15} = 53.57$
- 6) 18, 20
- 7) 575
- 8) $D_3 = 25, Q_2 = 29, P_{35} = 26$
- 9) 256
- 10) $Q_2 = 165$.
- 11) $Q_2 = 41$
- 12) $Q_2 = 55$
- 13) 14, 12
- 14) $Q_2 = 11.25$
- 15) $Q_2 = 36$
- 16) $Q_1 = 220, Q_3 = 340$, (i) 55 (ii) 60
- 17) $Q_2 = 48$
- 18) $Q_1 = 9.725, D_6 = 10.725, P_{78} = 11.375$
- 19) $Q_1 = 52.1875, Q_2 = 57.75, Q_3 = 63.5625, 31$
- 20) $Q_1 = 58.67$

CHAPTER 2

Exercise 2.1

- 1) 717
- 2) 11
- 3) 10
- 4) 5.5
- 5) 17.5
- 6) 2
- 7) 5.625
- 8) 1.965

Exercise 2.2

- 1) $8, 2\sqrt{2}$,
- 2) 380, $2\sqrt{95}$,
- 3) 6.1911, $\sqrt{6.1911}$,
- 4) 4.8, $\sqrt{4.8}$,
- 5) 1.2, $\sqrt{1.2}$,
- 6) 2, 4
- 7) $\sqrt{3.3514}$
- 8) 15.5 – 25.5, 25.5 – 35.5,, 95.5 – 105.5

Exercise 2.3

- 1) 44, $\sqrt{55.6516}$
- 2) $\sqrt{10.5}$
- 3) 31.62%
- 4) 20%
- 5) 3.76
- 6) $CV(P) = 27.27\%$, $CV(Q) = 33.33\%$
- i) Worker P is more consistent.

- ii) Worker Q seems to be faster in completing the job.
- 7) $CV_1 = 1.07\%$, $CV_2 = 2.5\%$
- i) First department has a larger bill.
- ii) Second department has larger variability in wages.
- 8) 22.36%
- 9) $CV(A) = 42.49\%$, $CV(B) = 33.50\%$
Team B is more consistent.
- 10) $CV(M) = 10\%$, $CV(S) = 12\%$
Statistics shows more variability

MISCELLANEOUS EXERCISE - 2

- 1) 89
- 2) 30
- 3) 60
- 4) 16.75
- 5) 12.59
- 6) 4.84
- 7) 3.75
- 8) 6.6, 2.57
- 9) 2.16, $\sqrt{2.16}$
- 10) 78, 17.20, 22.05%
- 11) 50, 44.84
- 12) 40.4, $\sqrt{81.13}$
- 13) 75, 10.07
- 14) $\sqrt{7.5}$
- 15) $CV_1 = 22.22\%$, $CV_2 = 20.83\%$, Brand II is more variable
- 16) 39.49%

CHAPTER 3

Exercise 3.1

- 1) - 0.45
- 2) 63, 61
- 3) 1
- 4) 29
- 5) -0.1881, Negatively skewed
- 6) 0
- 7) -0.5
- 8) -0.143

MISCELLANEOUS EXERCISE - 3

- 1) 1
- 2) -1.5
- 3) 0.2
- 4) -0.2
- 5) 70, 30
- 6) 195.2, 198.4
- 7) 0.4760
- 8) 0.3194
- 9) 1.3182
- 10) 0.6

CHAPTER 4

Exercise 4.1

1. Bivariate frequency distribution :

X	200-300	300-400	400-500	Total
Y				
200-300	6	6	1	13
300-400	-	4	5	10
400-500	-	-	2	2
Total	6	10	9	25

- i) Marginal frequency distributions of income (X) :

X	200-300	300-400	400-500	Total
Frequency	6	10	9	25

Marginal frequency distributions of expenditure (Y) :

Y	200-300	300-400	400-500	Total
Frequency	13	10	2	25

- ii) Conditional frequency distributions of X when Y is between 300-400

X	200-300	300-400	400-500	Total
Frequency	-	4	6	10

- iii) Conditional frequency distributions of Y when X is between 200-300

Y	200-300	300-400	400-500	Total
Frequency	6	-	-	6

- iv) Number of families having their income \geq Rs.300 and expenses \leq Rs.400

$$= 6 + 1 + 4 + 6 = 17$$

2. Bivariate frequency distribution :

X \ Y	2	3	4	5	6	f _y
1	-	1	2	-	1	4
2	-	1	-	2	-	3
3	2	1	3	-	-	6
4	-	2	-	-	1	3
5	5	-	3	1	-	9
f _x	7	5	8	3	2	25

Marginal frequency distributions of income (X) :

X	2	3	4	5	6	Total
Frequency	7	5	8	3	2	25

Marginal frequency distributions of expenditure (Y) :

Y	1	2	3	4	5	Total
Frequency	4	3	6	3	9	25

3. Bivariate frequency distribution :

X \ Y	25	26	27	28	29	Total
19	(2)	(1)	-	-	-	3
20	(2)	(1)	-	(2)	-	5
21	-	(2)	(1)	-	-	3
22	-	-	(3)	(1)	-	4
23	(2)	-	(1)	-	(2)	5
Total	6	4	5	3	2	20

i) Marginal distributions of X :

X	25	26	27	28	29	Total
F	6	4	5	3	2	20

ii) Marginal distributions of Y :

Y	19	20	21	22	23	Total
F	3	5	3	4	5	20

iii) Conditional frequency distributions of age of husbands (X) when the age of wife (Y) is 23 years. :

X	25	26	27	28	29	Total
F	2	-	1	-	2	5

4. Let X denotes the marks in stats and Y denotes the marks in English Bivariate frequency distribution :

X \ Y	20-30	30-40	40-50	Total
20-30	(1)	(2)	(1)	4
30-40	(3)	(2)	(11)	7
40-50	(2)	(1)	(1)	4
Total	6	5	4	15

i) Marginal frequency distributions of (X) :

X	20-30	30-40	40-50	Total
F	6	5	4	15

Marginal frequency distributions of (Y) :

Y	20-30	30-40	40-50	Total
F	4	7	4	15

ii) Conditional frequency distributions of Y and X = 47

X	20-30	30-40	40-50	Total
F	2	2	1	15

5. Bivariate frequency distribution :

X \ Y	35-39	40-44	45-49	50-54	Total
150-154	(3)	(2)	(1)	(1)	7
155-159	(1)	(3)	(2)	(1)	7
160-165	-	-	(1)	(3)	4
165-169	-	-	-	(2)	2
Total	4	5	4	7	20

i)(a) Marginal frequency distribution of X :

X	35-39	40-44	45-49	50-54	Total
F	4	5	4	7	20

(b) Marginal frequency distribution of Y :

Y	150-154	155-159	160-164	165-169	Total
F	6	8	4	2	20

ii) Conditional frequency distribution of Y, when $155 \leq X \leq 159$

Y	150-154	155-159	160-164	165-169	Total
F	1	3	3	1	8

Ex. 4.2 :

- 1) 0 2) 3.37 3) 1.07 4) 2.66 5) 30.625

MISCELLANEOUS EXERCISE - 4

1.

X/Y	0-4	5-9	10-14	15-19	Total
5-8	(2)	-	(3)	(1)	6
9-12	(2)	(9)	(1)	-	12
13-16	(1)	(6)	(4)	(1)	12
Total	5	15	8	2	30

i)(a) Marginal frequency distribution of X :

X	0-4	5-9	10-14	15-19	Total
F	5	15	8	2	30

(b) Marginal frequency distribution of X :

X	5-8	9-12	13-16	Total
F	6	12	12	30

ii) Conditional frequency distribution of X, when $X < 10$

Y	5-8	9-12	13-16	Total
F	2	11	7	20

2. Let us denote the age by X and marks by Y

Y/X	16-18	18-20	20-22	22-24	Total
10-20	(2)	-	-	-	2
20-30	-	-	-	-	-
30-40	-	-	(1)	(5)	6
40-50	(3)	(2)	(3)	(1)	9
50-60	(2)	(2)	(4)	(1)	9
60-70	-	(1)	(1)	(2)	4
Total	7	5	9	9	30

i)(a) Marginal frequency distribution of X :

X	16-18	18-20	20-22	22-24	Total
F	7	5	9	9	30

(b) Marginal frequency distribution of Y :

Y	10-20	20-30	30-40	40-50	50-60	60-70	Total
F	2	-	6	9	9	4	30

ii) Conditional frequency distribution of marks (Y), when age is in 20-22

Y	10-20	20-30	30-40	40-50	50-60	60-70	Total
F	-	-	1	3	4	1	9

3.i)

X/Y	115-125	125-135	135-145	145-155	155-165	165-175	Total
60-62	2	1	-	-	-	-	3
62-64	1	-	3	-	-	-	4
64-66	1	1	2	1	-	-	5
66-68	-	2	-	2	-	-	4
68-70	-	1	1	-	1	1	4
Total	4	5	6	3	1	1	20

i)(a) Marginal frequency distribution of X :

X	115-125	125-135	135-145	145-155	155-165	165-175	Total
F	4	5	6	3	1	1	20

(b) Marginal frequency distribution of Y :

Y	60-62	62-64	64-66	66-68	68-70	Total
F	3	4	5	4	4	20

iii) Conditional frequency distribution of sales when expenditure is between 64-66

X	115-125	125-135	135-145	145-155	155-165	165-175	Total
F	1	1	2	1	-	-	5

iv) Conditional frequency distribution of expenditure when sales are between 125-135

Y	60-62	62-64	64-66	66-68	68-70	Total
F	1	-	1	2	1	5

4.

Y/X	35-45	45-55	55-65	65-75	Total
115-130	(4)	-	-	-	4
130-145	(2)	(1)	(3)	-	6
145-160	(1)	(1)	(2)	(3)	7
160-175	(1)	(2)	(2)	(2)	7
Total	8	4	7	5	24

i)(a) Marginal frequency distribution of X :

X	35-45	45-55	55-65	65-75	Total
F	8	4	7	5	24

(b) Marginal frequency distribution of Y :

Y	115-130	130-145	145-160	160-175	Total
F	4	6	7	7	24

(ii) Conditional frequency distribution of Y, when $X \leq 45$

Y	115-130	130-145	145-160	160-175	Total
F	4	2	1	1	8

5.

Y/X	80-90	90-100	100-110	110-120	120-130	Total
500-600	-	(1)	-	(2)	(1)	4
600-700	(2)	(2)	(2)	(1)	-	7
700-800	(1)	(4)	-	-	(1)	6
800-900	(1)	(3)	(1)	-	(3)	8
900-1000	(3)	(1)	-	(1)	-	5
Total	7	11	3	4	5	30

i) Marginal frequency distribution of X :

X	80-90	90-100	100-110	110-120	120-130	Total
F	7	11	3	4	5	30

ii) Marginal frequency distribution of Y :

Y	500-600	600-700	700-800	800-900	900-1000	Total
F	4	7	6	8	5	30

6) 2.38 7) 0.67 8) 10.614 9) 4.31 10) 0.4076

CHAPTER 5

Exercise 5.1

- 1) Positive correlation
- 2) Positive Correlation
- 3) NO Correlation
- 4) 0.89
- 5) 18.75
- 6) i) 5 ii) -0.92
- 7) 0.1732
- 8) 13.33.

MISCELLANEOUS EXERCISE 5

- 1) 0.5
- 2) 10
- 3) 9

- 4) 10
- 5) 0.94, High degree of positive correlation
- 6) -1. Perfect negative correlation
- 7) 1, Perfect positive correlation
- 8) No change
- 9) Same value

CHAPTER 6

Exercise 6.1

- 1) 50
- 2) 30, 20
- 3) 12
- 4) (i) 25, (ii) 20
- 5) (i) 100 (ii) 48
- 6) 125
- 7) 124
- 8) 31
- 9) 90
- 10) 225
- 11) 24
- 12) 276
- 13) 207
- 14) 12
- 15) 216

Exercise 6.2

- 1) (i) 40320 (ii) 720 (iii) 39600 (iv) 2
- 2) (i) 665280 (ii) 2 (iii) 720 (iv) 12
- 3) (i) 84 (ii) 29 (iii) 5793 (iv) 20160
- 4) (i) $\frac{10!}{4!}$ (ii) $3^5 \times 5!$ (iii) $\frac{9!}{5!}$ (iv) $5^5 \times 5!$
- 5) (i) 28 (ii) 1
- 6) (i) 1848 (ii) $\frac{43}{14}$ (iii) 5

7) (i) 6 (ii) 8

8) (i) 7 (ii) 8

9) (i) 11 (ii) 11

10) 5

13) (i) 3370 (ii) $\frac{8}{25}$

14) $\frac{(2n)!}{n!} = 2^n (2n-1)(2n-3)\dots 5.3.1$

Exercise 6.3

1) 9

2) $m = 6, n = 2$

3) 6

5) (i) 2401 (ii) 840

6) (i) 30240 (ii) 25200 (iii) 1800 (iv) 5040

7) $\frac{12!.13!}{7}$

8) (i) 1440 (ii) 720

9) 144

10) (i) 1296 (ii) 360

11) 100

12) 720 (i) 120 (ii) 600

13) (i) 46,800 (ii) 20,800

14) 243

15) (i) 2880 (ii) 5040

Exercise 6.4

1) (i) 120 (ii) 60480 (iii) 90720 (iv) 5040

2) 1260

3) (i) 70 (ii) 37

4) $\frac{13!}{5!.4!.4!}$

5) $\frac{12!}{2!.3!.2!}, \frac{8 \times 5!}{2! \times 3! \times 2!}$

6) $\frac{11!}{4!.2!.2!}$ (i) $\frac{9!.^{10}P_2}{4 \times 2 \times 2!}$ (ii) $\frac{8!}{2! \times 2!}$

7) 210

8) 60

9) $\frac{10!}{2!.3!.2!}$

10) 1260, 660

11) 180

12) 144

13) 360, 180

14) 180, 60

15) (i) 1800 (ii) 72

Exercise 6.5

1) 5040

2) $20!, 18! \times 2!$

3) (i) $22! \times 2!$, (ii) $2! \times 22!$

4) $\frac{14!}{2!}$

5) $18! \times 2!$

6) (i) $5! \times 2!$, (ii) $5! \times {}^5P_2$

7) $7! \times {}^8P_6$

8) $4! \times {}^3P_2$

9) $\frac{9!}{4!}$

10) $12 \times 13!$

Exercise 6.6

1) (i) 1365 (ii) 3160

(iii) ${}^{16}C_5 = 4368$ (iv) ${}^{19}C_{15} = 3876$

2) (i) 2 (ii) 7 (iii) 9

3) 4

4) (i) $n = 10, r = 3$, (ii) $n = 10, r = 4$

5) 8

6) 126

7) 7000

- 8) 120
- 9) 12
- 10) 190
- 11) ${}^n C_2 - n$; (a) 35 (b) 90 (c) 54
- 12) 190
- 13) (i) 45, (ii) 40
- 14) (i) 220, (ii) 216
- 15) 151200

Exercise 6.7

- 1) 20
- 2) 4
- 3) 1, 5 or 2
- 4) $n-1$
- 5) 6
- 6) $\frac{1}{r!}$
- 7) 11 or 7
- 8) ${}^{21} C_5$
- 9) (i) 2508, (ii) 1646, (iii) 4125
- 10) 16
- 11) 2275
- 12) 36873, 6885
- 13) 425
- 14) 51051
- 15) (a) 84, (b) 126

MISCELLANEOUS EXERCISE - 6

- 1) 41
- 2) 120
- 3) 720 AENREM
- 4) $n^n, n!$
- 5) 420
- 6) 990
- 7) 360

- 8) ${}^{26} C_6 + {}^{26} C_{10}$
- 9) 15
- 10) ${}^{30} C_7 \times {}^{23} C_{10} \times {}^{13} C_{13}$
- 11) 127
- 12) 336
- 13) 150
- 14) 1023
- 15) 48
- 16) ${}^8 P_4 = 1680$
- 17) $2^6 - 1 = 63$
- 18) ${}^{20} C_8 \times {}^{12} C_7 \times {}^5 C_5$
- 19) 924
- 20) 60

CHAPTER 7

Exercise 7.1

- 1) a) $S = \{HH, TH, HT1, HT2, HT3, HT4, HT5, HT6, TT1, TT2, TT3, TT4, TT5, TT6\}$ $n(S) = 14$
 b) $S = \{HH1, HH2, HH3, HH4, HH5, HH6, TH1, TH3, TH4, TH5, TH6, HTH, HTT, TTH, TTT\}$ $n(S) = 16$
- 2) $S = \{BB, BR, BG, RB, RR, RG, GB, GR, GG\}$ $n(S) = 9$
- 3) $S = \{H1, H2, H3, H4, H5, H6, T1, T2, T3, T4, T5, T6\}$
 a) $A = \{H2, H4, H6\}$
 b) $B = \{H2, H3, H5, T2, T3, T5\}$
 c) $C = \{T1, T4\}$
- 4) a) 2300, b) 21, c) 120, d) 720
- 5) a) $P = \{(1,2), (1,3), (1,5), (2,1), (2,2), (2,4), (2,6), (3,1), (3,3), (3,5), (3,6), (4,2), (4,4), (4,5), (5,1), (5,3), (5,4), (6,2), (6,3), (6,6)\}$

- b) $Q = \{(1, 6), (2, 5), (3, 4), (4, 3), (5, 2), (6, 1)\}$
- c) $R = \{(1, 1), (1, 2), (1, 4), (1, 6), (2, 1), (2, 3), (2, 5), (3, 2), (3, 4), (4, 1), (4, 3), (5, 2), (5, 6), (6, 1), (6, 5)\}$
- i) P and Q are mutually exclusive but not exhaustive.
- ii) Q and R are not mutually exclusive not exhaustive.
- 6) a) 52 b) 52
- 7) $S = \{(H_1 R_{11}), (H_1 R_{12}), (H_1 R_{13}), (H_1 B_{11}), (H_1 B_{12}), (T_1 R_{21}), (T_1 R_{22}), (T_1 B_{21}), (T_1 B_{22}), (T_1 B_{23}), (T_1 B_{24})\}$
- 8) a) $S = \{(5, 5), (5, 6), (5, 7), (5, 8), (6, 5), (6, 6), (6, 7), (6, 8), (7, 5), (7, 6), (7, 7), (7, 8), (8, 5), (8, 6), (8, 7), (8, 8)\}$
- b) $S = (5, 6), (5, 7), (5, 8), (6, 5), (6, 7), (6, 8), (7, 5), (7, 6), (7, 8), (8, 5), (8, 6), (8, 7)$

- c) $1 - \frac{{}^{39}C_4}{{}^{52}C_4}$ d) $\frac{{}^{12}C_3 \times {}^1C_1}{{}^{52}C_4}$
- 4) a) $\frac{7}{15}$ b) 5, 7, 3
- 5) a) $\frac{12}{75}$ b) $\frac{8}{75}$
- c) $\frac{7}{25}$ d) $\frac{1}{15}$
- 6) a) $\frac{{}^8C_3 \times {}^5C_2}{{}^{13}C_5}$ b) $\frac{{}^8C_3 \times {}^5C_2 + {}^8C_4 \times {}^5C_1 + {}^8C_5 \times {}^5C_0}{{}^{13}C_5}$
- 7) $\frac{5}{6}$
- 8) a) $\frac{7! \times 3!}{9!}$ b) $\frac{6! \times {}^7P_3}{9!}$
- c) $\frac{7! \times 4}{9!}$ d) $\frac{7!}{9!}$ e) $\frac{3 \times 6 \times 7!}{9!}$
- 9) $\frac{4!3!}{6!} = \frac{1}{5}$

Exercise 7.2

- 1) a) $\frac{1}{9}$ b) $\frac{1}{12}$ c) $\frac{1}{6}$
- d) $\frac{11}{12}$ e) $\frac{1}{6}$ f) $\frac{1}{6}$
- 2) a) $\frac{{}^{26}C_2}{{}^{52}C_2}$ b) $\frac{{}^{13}C_2}{{}^{52}C_2}$ c) $\frac{{}^4C_2}{{}^{52}C_2}$
- d) $\frac{{}^{12}C_2}{{}^{52}C_2}$ e) $\frac{{}^{13}C_1 {}^{39}C_1}{{}^{52}C_2}$ f) $\frac{4 \times {}^{13}C_2}{{}^{52}C_2}$
- g) $\frac{13[{}^4C_2]}{{}^{52}C_2}$
- 3) a) $\frac{{}^4C_3 \times {}^4C_1}{{}^{52}C_4}$ b) $\frac{{}^{13}C_1 \times {}^{13}C_1 \times {}^{13}C_1 \times {}^{13}C_1}{{}^{52}C_4}$

Exercise 7.3

- 1) $\frac{23}{36}$
- 2) a) 1, b) $\frac{8}{13}$
- 3) a) $\frac{25}{51}$ b) $\frac{55}{221}$
- 4) a) $\frac{8}{25}$ b) $\frac{3}{5}$
- 5) a) $\frac{4}{5}$ b) $\frac{1}{2}$ c) $\frac{1}{5}$
- 6) a) $\frac{3}{20}$ b) $\frac{1}{10}$ c) $\frac{1}{4}$
- d) $\frac{17}{20}$ e) $\frac{1}{2}$

7) $\frac{97}{120}$

8) $\frac{4}{13}$

9) $\frac{16}{35}$

Exercise 7.4

1) $\frac{2}{11}$

2) $\frac{1}{6}$

3) $\frac{36}{61}$

4) independent

5) a) $\frac{3}{5}$ b) $\frac{2}{5}$ c) $\frac{3}{20}$

6) 0.8051

7) a) $\frac{1}{2}$ b) 0.4 c) 0.3

8) 0.96

9) a) $\frac{1}{4}$ b) $\frac{1}{2}$

10) $\frac{10}{21}$

11) $\frac{13}{35}$

12) $\frac{47}{90}$

13) $\frac{9}{169}$

MISCELLANEOUS EXERCISE - 7

1) $S = \{(m_1, m_2), (m_1, w_1), (m_1, w_2), (m_1, w_3), (m_2, w_1), (m_2, w_2), (m_2, w_3), (w_1, w_2), (w_1, w_3), (w_2, w_3)\}$

$E = \{(m_1, w_1), (m_1, w_2), (m_1, w_3), (m_2, w_1), (m_2, w_2), (m_2, w_3)\}$

2) $\frac{13}{32}$

3) $\frac{5}{6}$

4) $\frac{9}{10}$

5) $\frac{37}{50}$

6) $\frac{4}{13}$

7) $A_1, A_2,$ and A_3 are pair wise independent. They are not mutually independent.

8) $\frac{52}{77}$

9) a) $\frac{15}{91}$ b) $\frac{59}{91}$

10) $\frac{25}{648}$

11) 0.27

12) $\frac{20}{81}$

13) $\frac{7}{429}$

14) a) $\frac{73}{105}$ b) $\frac{32}{105}$

CHAPTER 8

Exercise 8.1

1) i) $-4 \leq x \leq \frac{7}{3}$, bounded

ii) $0 < x \leq 0.9$, bounded

iii) $-\infty < x < \infty$, unbounded

iv) $5 \leq x < \infty$, unbounded

v) $-11 < x < -2$, unbounded

vi) $-\infty < x < 3$, unbounded

2) i) $x > 12$, $x \in (12, \infty)$

ii) $x \leq 3$, $x \in (-\infty, 3]$

iii) $5 < x < 17$, $x \in (5, 17)$

iv) $-\frac{6}{7} < x < 2$, $x \in (-\frac{6}{7}, 2)$

3) Graph

1) i)

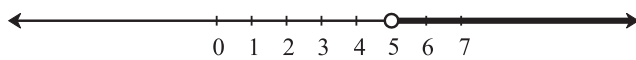

ii)

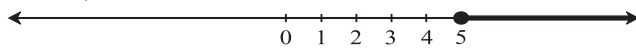

iii)

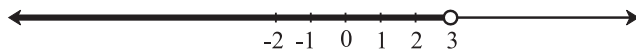

iv)

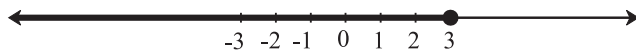

v)

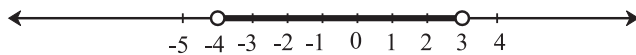

vi)

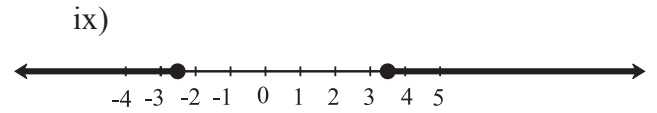
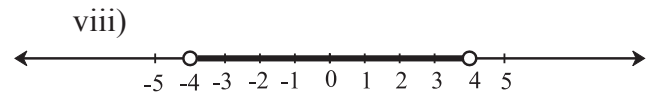
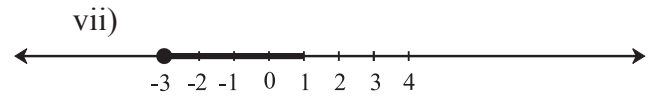
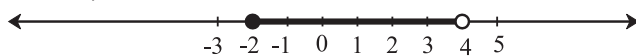

4) (i) $x > -\frac{3}{7}$, $x \in (-\frac{3}{7}, \infty)$

(ii) $x \leq \frac{5}{3}$, $x \in (-\infty, \frac{5}{3}]$

(iii) $x < 5$, $x \in (-\infty, 5)$

(iv) $x \geq 4$, $x \in [4, \infty)$

(v) $-\frac{8}{3} \leq x < \frac{13}{3}$, $x \in [-\frac{8}{3}, \frac{13}{3})$

(vi) $10 \leq x < 20$, $x \in [10, 20)$

(vii) $x \leq \frac{-1}{10}$ or $x \geq \frac{17}{10}$,
 $x \in (-\infty, -\frac{1}{10}) \cup [\frac{17}{10}, \infty)$

(viii) $-16 \leq x \leq 9$, $x \in [-16, 9]$

(ix) $x < -\frac{7}{2}$ or $x > -\frac{5}{2}$,
 $x \in (-\infty, -\frac{7}{2}) \cup (-\frac{5}{2}, \infty)$

(x) $-5 < x < 3$, $x \in (-5, 3)$

5) 35

6) 82

7) (5, 7)

8) (6, 8), (8, 10), (10, 12)

9) 41

Exercise 8.2

1)

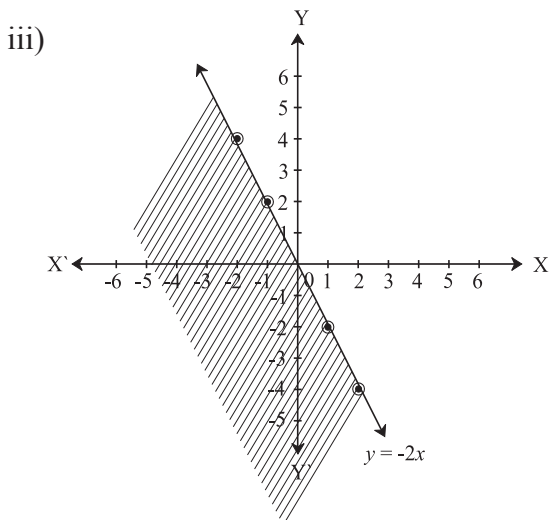
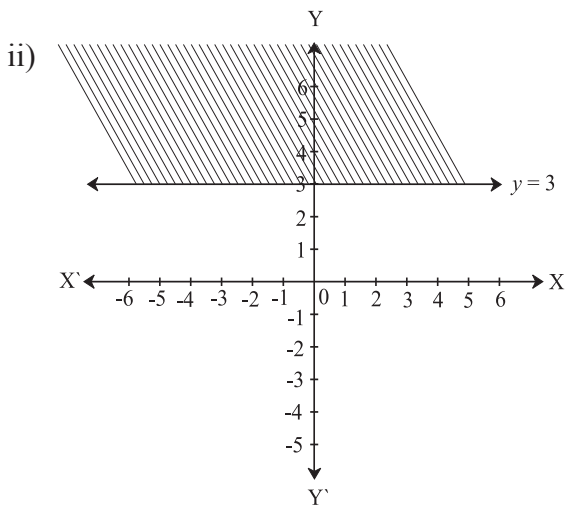
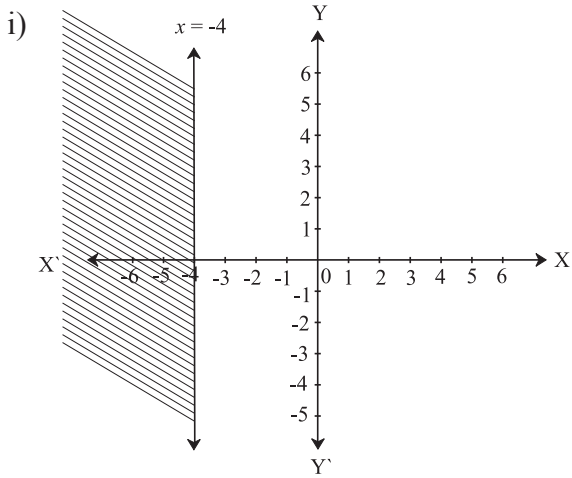

iv)

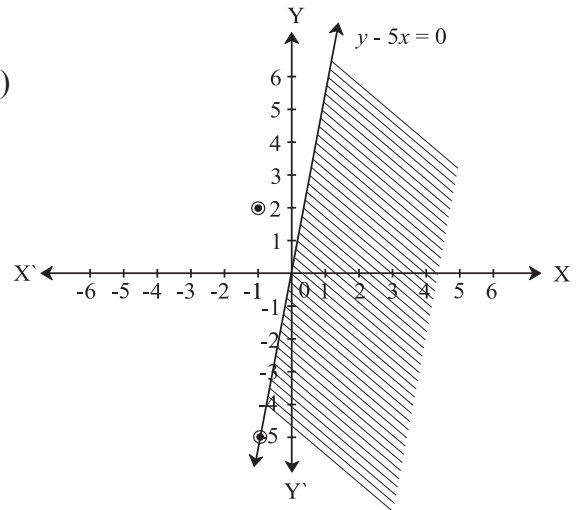

v)

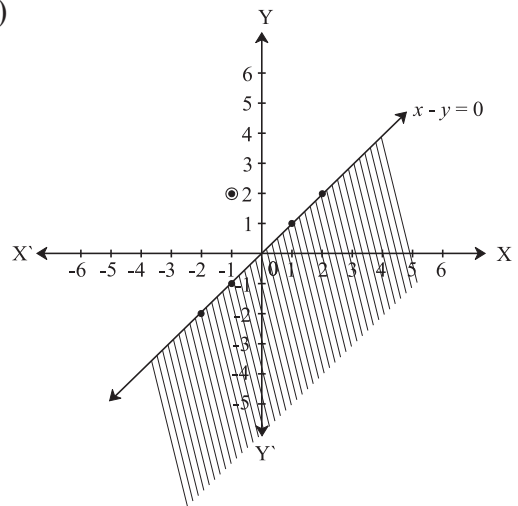

vi)

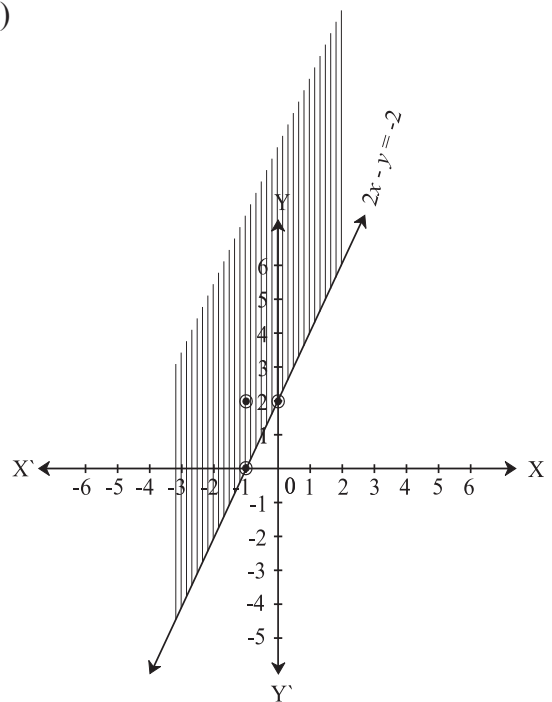

vii)

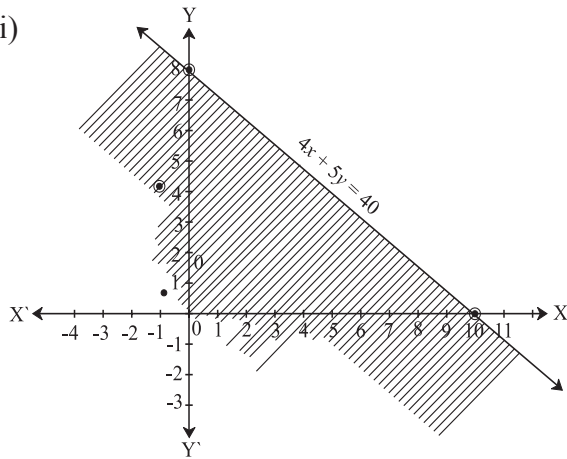

3) $200 F_1 + 100 F_2 \geq 4000$

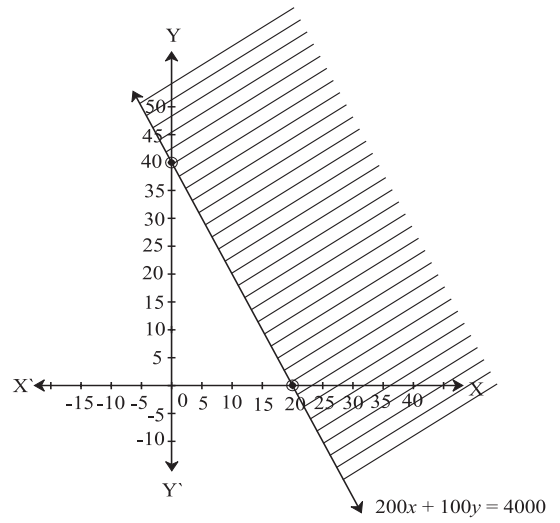

viii)

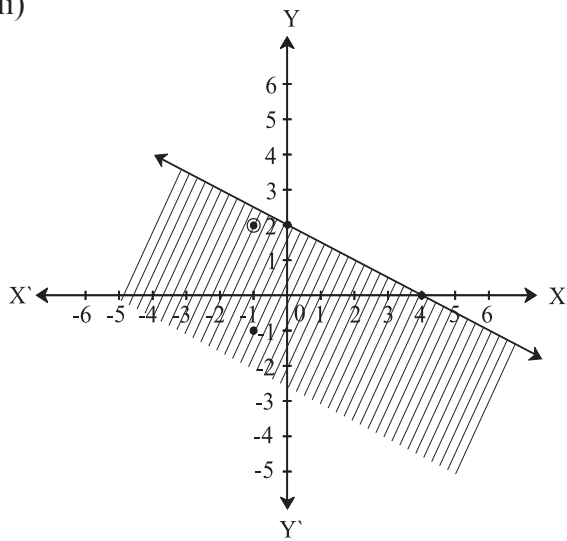

2) $150x + 200y \leq 1800$

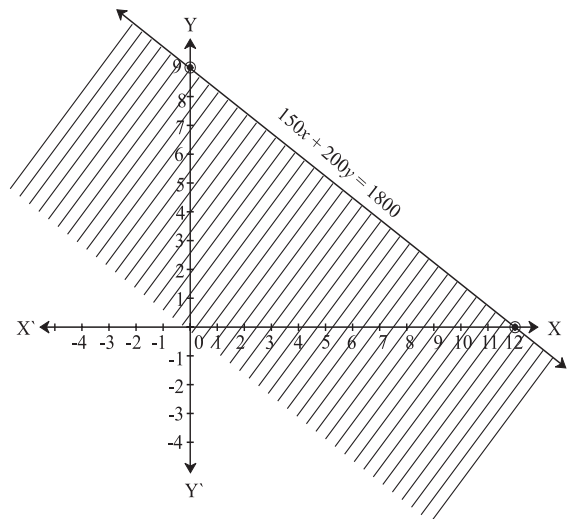

Exercise 8.3

1.

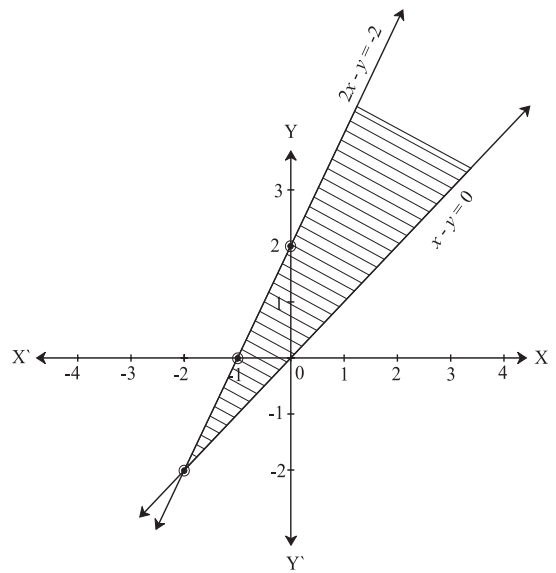

2.

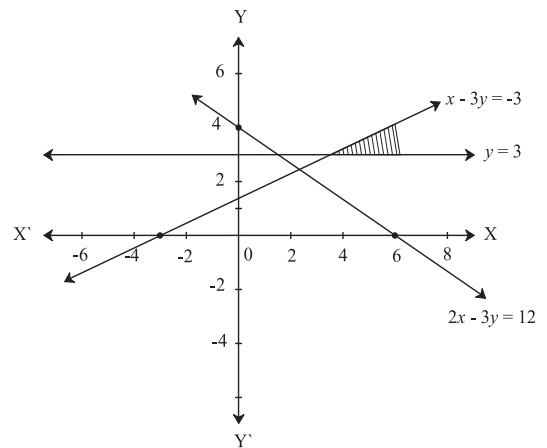

3.

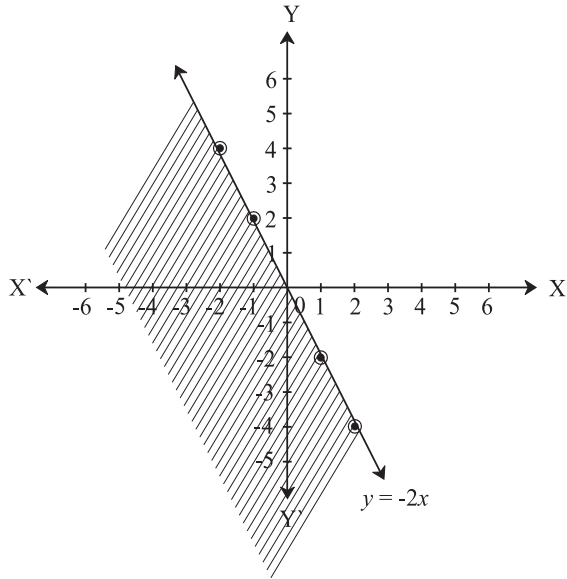

6.

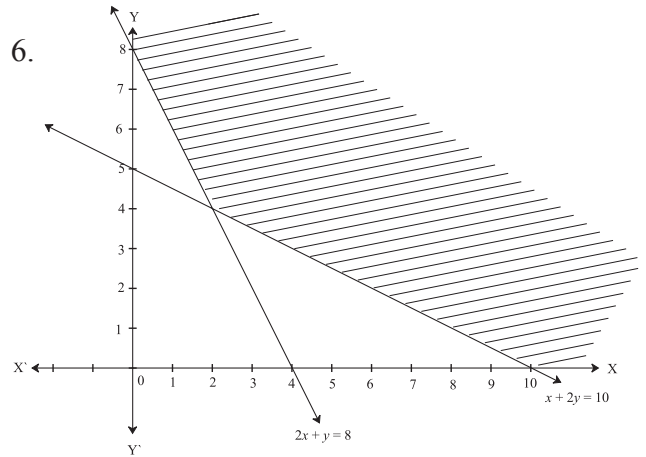

4.

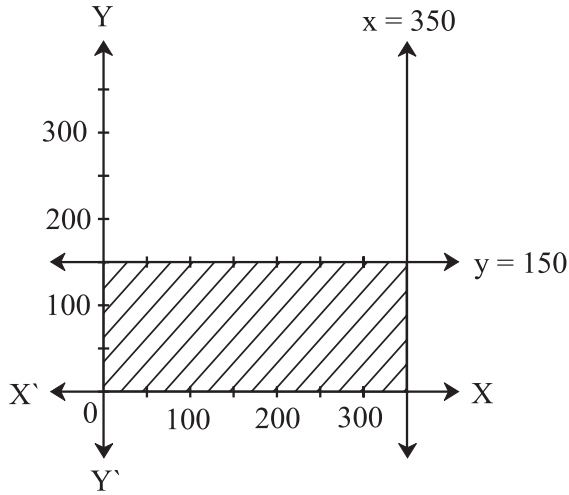

7.

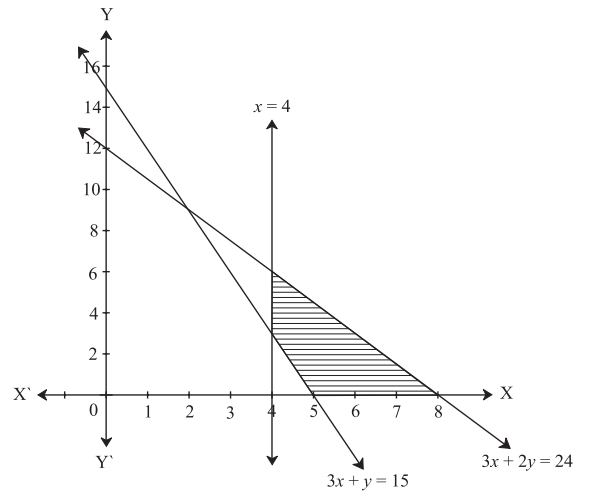

5.

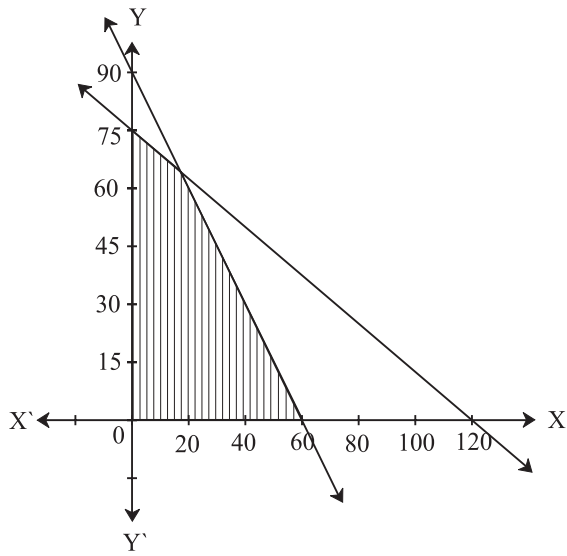

MISCELLANEOUS EXERCISE - 8

1.

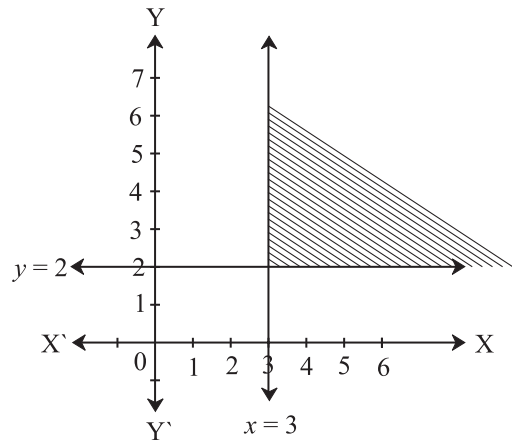

2.

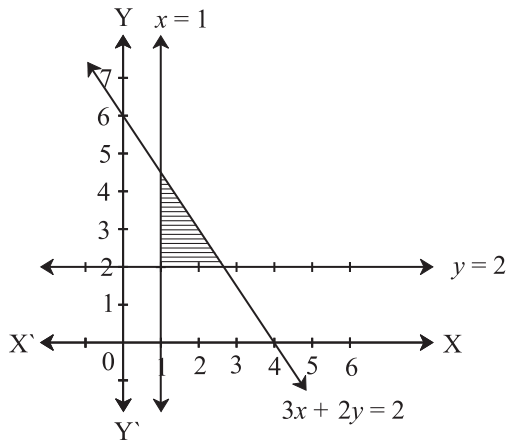

5.

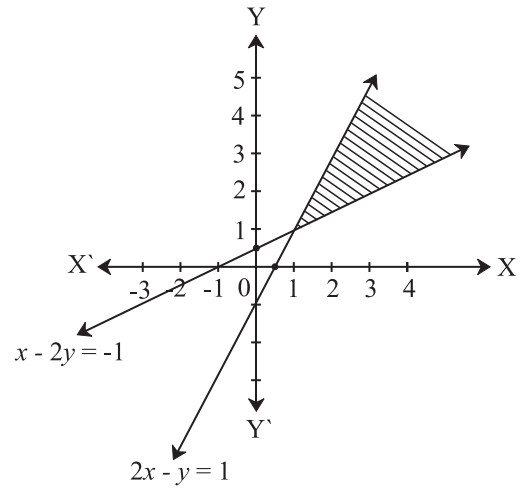

3.

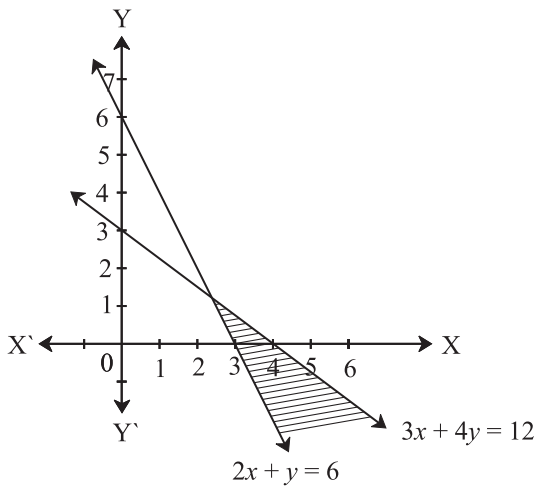

6.

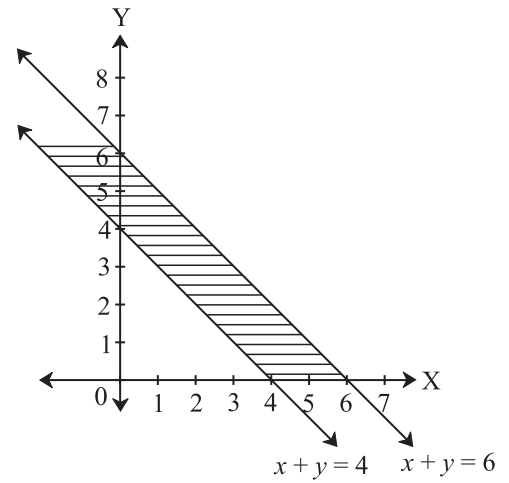

4.

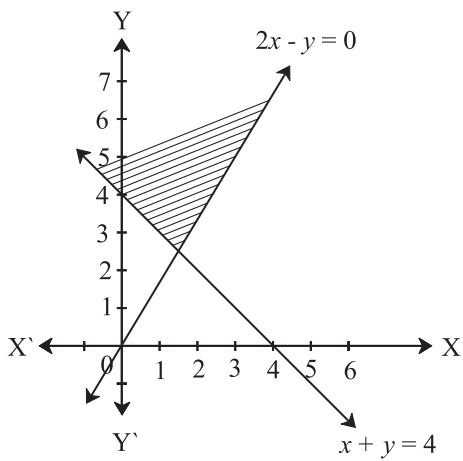

7.

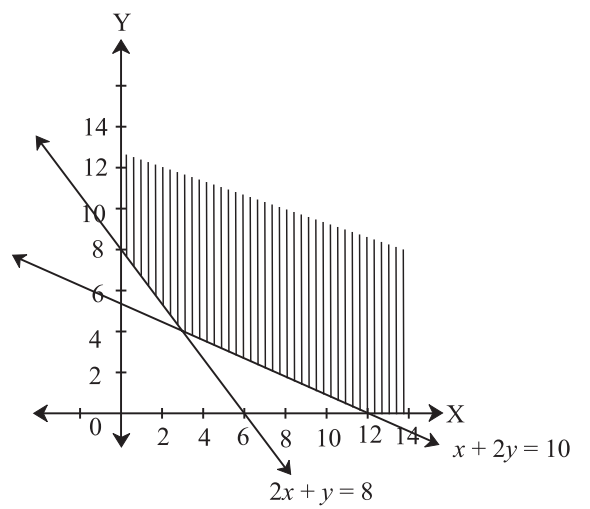

8.

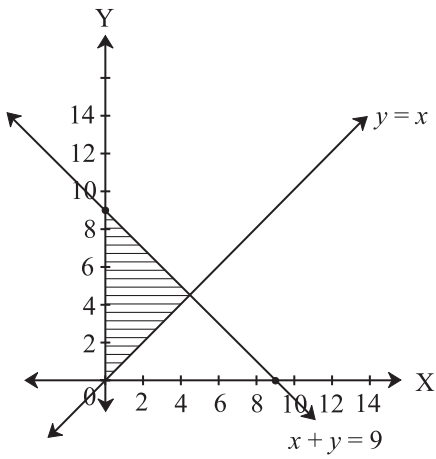

11.

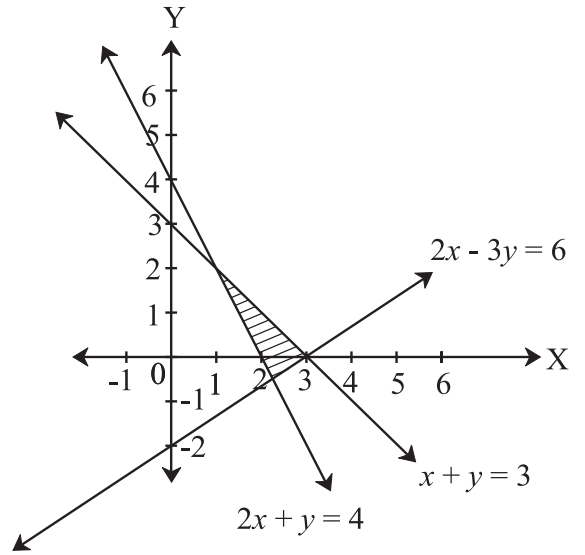

9.

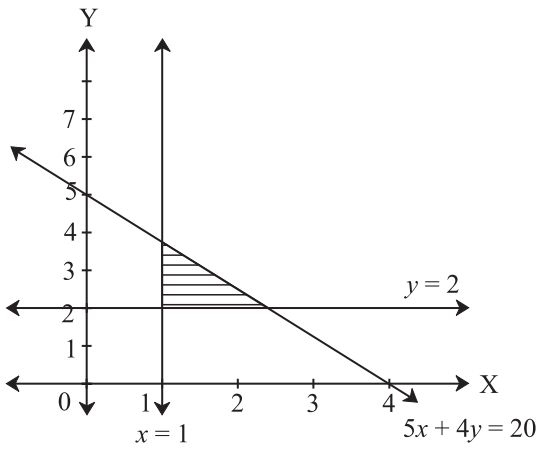

12.

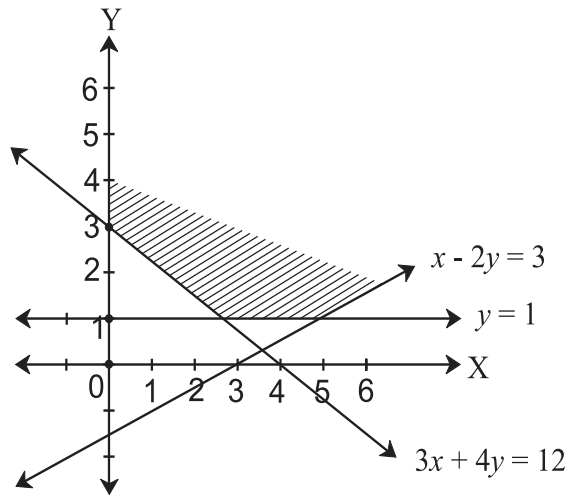

10.

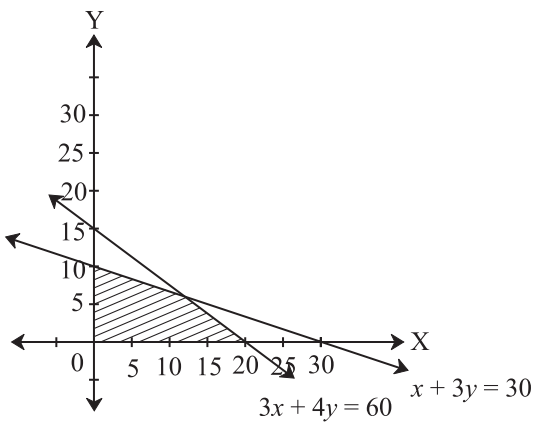

13.

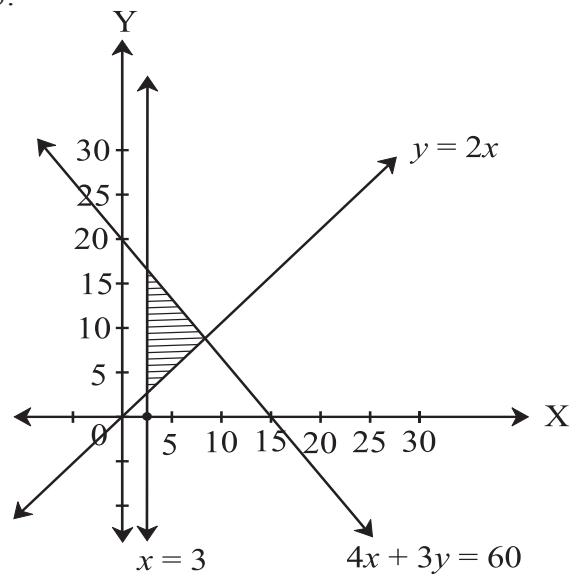

14.

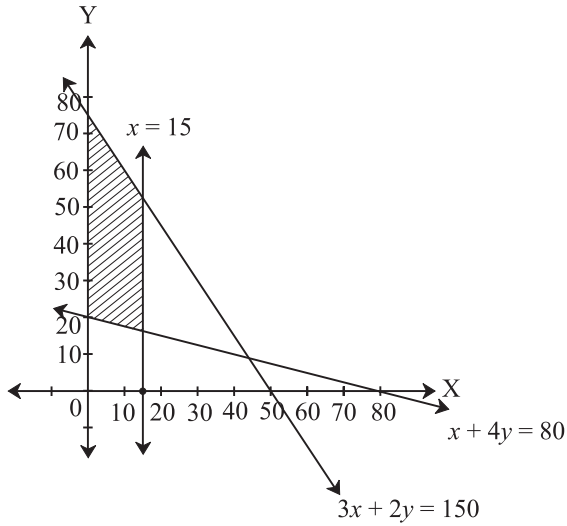

15.

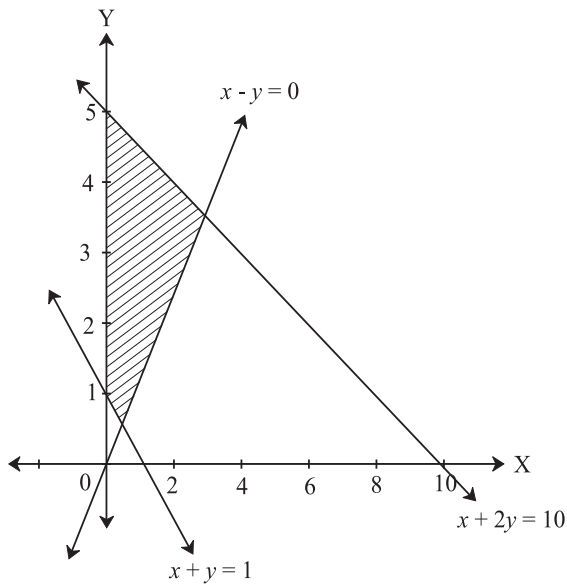

7. Rs.16
8. 28.57%
9. 50%

Exercise 9.2

1. 25%
2. Profit Rs.600
3. 5 toffees
4. Rs.3000
5. 0.8 cm.
6. 24%
7. Rs.540
8. 125%
9. 31.25%
10. Rs.1550
11. 19.6%
12. 50%
13. 20% (Rs.90)
14. Rs.200
15. Loss 2.25%

Exercise 9.3

1. Rs.1728
2. Rs.1428
3. Rs.519.75
4. Rs.662.025
5. Rs.1698.58
6. 3 years
7. 10 years
8. Rs. 500
9. Rs.630.5
10. Rs.2050
11. Rs.5000

CHAPTER 9

Exercise 9.1

1. 579.2
2. 85%
3. 2%
4. 25%
5. Rs.100
6. 0.15%

Exercise 9.4

- 1) Rs.180000 = Value after 2 years
- 2) Rs. = 12.5 = Rate of Depreciation
- 3) Purchase price of machine = 300000
- 4) No. of years = 3
- 5) Value after 3 years = Rs. 343000
- 6) Rate of depreciation $r = 10\%$
- 7) Value after 2 years = Rs.4512500
- 8) No of years $n = 4$

Exercise 9.5

1. 50:72:105
2. 3:4:7
3. Rs. 50,000
4. Rs. 4,000
5. Rs. 46,000
6. 11 months
7. 3/11
8. Rs. 50,000
9. Rs. 1,080
10. Rs. 59,000

Exercise 9.6

1. CGST = Rs.9650, SGST = Rs.9650
2. ITC = Rs.25,000, GST = Rs.4500
3. ITC = Rs. 60,000, GST = Rs.12,000
4. Activity
5. GST payable by Heena Enterprise = Rs. 4500
GST payable by Leena Traders = Rs. 5400 – Rs. 4500 = Rs. 900
GST payable by Meena Beauty Products =

$$\text{Rs. } 7200 - \text{Rs. } 5400 = \text{Rs. } 1800$$

$$\text{CGST} = \text{Rs. } 3600 \quad \text{SGST} = \text{Rs. } 3600$$

6. Input Tax = Rs.1,40,000 , Output Tax = Rs. 2.24,000 , ITC = Rs. 1.40.000
CGST = (Rs. 70,000 + Rs.42000) = Rs. 1,12,000 ,SGST= Rs. 1,12,000
7. Bill Amount = Rs.399

Exercise 9.7

1. (i) First firm is paying better
(ii) Rs. 62,400
2. (i) Rs. 120
(ii) Rs.8400
3. First kind
4. (i) 50
(ii) Rs. 180
5. Rs.315; Rs. 675 less
6. Rs. 150
7. Tejas's
8. Rs 75
9. Rs. 800
10. (i) 200
(ii) Rs. 2400
11. Rs.2200
12. (i) 100
(ii) Rs.600
(iii) 712%
13. (i) Rs. 6400
(ii) 9.6 %
14. Rs.21,000
15. Rs. 2250
16. Rs. 25
17. (i) Rs. 9600
(ii) Rs. 960
(iii) Rs. 10%

18. (i) Rs. 42000
(ii) Rs. 4200
(iii) 10 %

MISCELLANEOUS EXERCISE - 9

- 1) Rs. 90000 = Annual Rent
2) Passing marks = 85
3) Loss = 25%
4) Gain = 50%
5) C. P.= Rs.400
6) Discount = 38.8%
7) Sum = 6000
8) Period = 2 years
9) Purchase Price = Rs. 10000
- 10) 10.75 meters
11) After 2 years
12) Investment in 'B' = Rs. 21000
13) Annual dividend = Rs.2000
14) B's share = Rs. 1600
15) Banta Invested for 11 months
16) Akash – Rs.9245.50
Sameer – Rs.5186.50
Sid – Rs.1804.00
17) CGST = SGST = Rs.61200
18) ITC = 48000
CGST = SGST = RS.9000



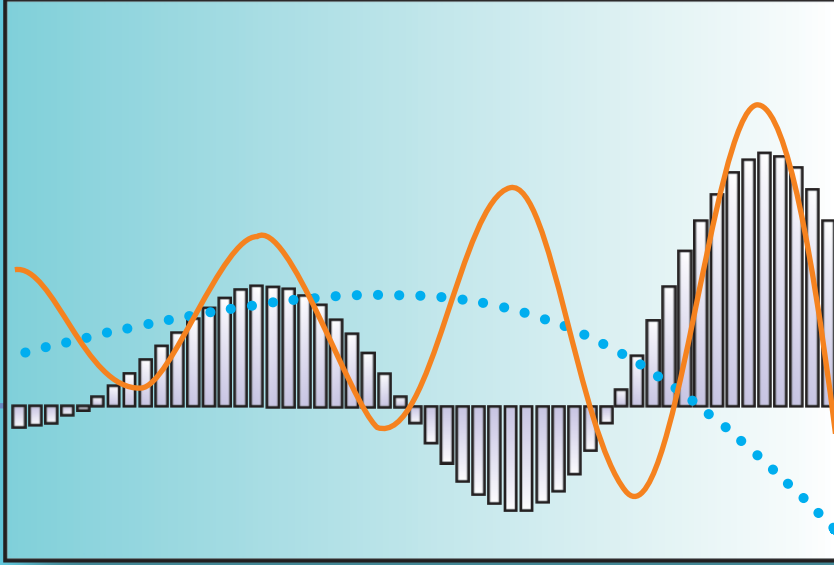

E-COMMERCE TRENDS IN INDIA



**Maharashtra State Bureau of Textbook
Production and Curriculum Research,
Pune - 411 004.**

₹ 98.00

इंग्रजी गणित आणि संख्याशास्त्र (वाणिज्य) भाग - २, इ. ११ वी