

3

Visual Arts and I

**An artist can never be unsuccessful.
Being an artist is a success in itself.**



Objectives

1. Students should be able to explain the importance of art in their own words.
2. Talk about the different styles in visual art, famous artists and the speciality of their style in their own words.
3. Get introduced to different types of art forms and be able to create an artwork.
4. Think about art and its place in human life.



Let us have some fun

Write the first letter of your name. See if you can create a picture of an animal, bird or an object using it. See if you can decorate the alphabet. Look at the examples given below –

Encourage the students. Let them begin with any letter.

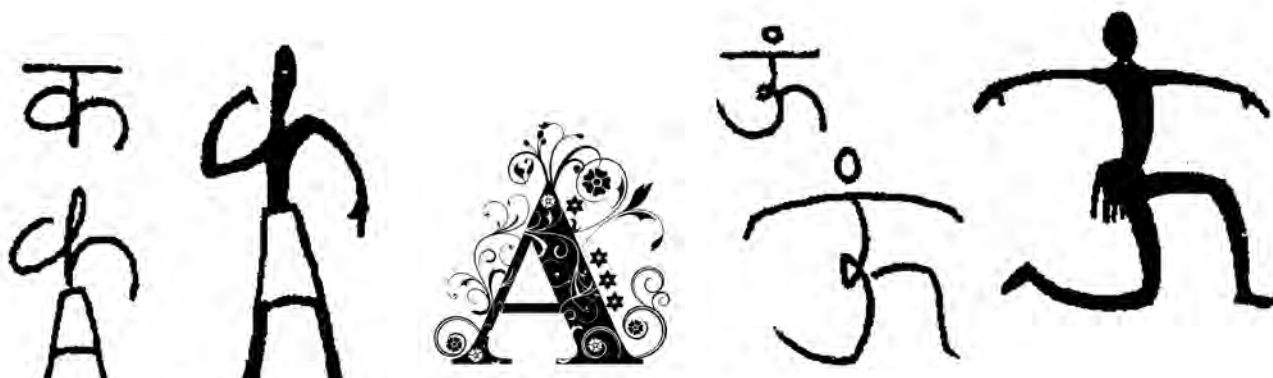

Last year we have learnt about visual art. This year we shall learn about its importance, different types and the possibility of choosing it as a career.

Importance of Art

'If you have two rupees then buy food with one and spend the other on art. Food will only help you survive but art will give you a reason to live.' From this, one can understand the importance of Art in human life.

Art enriches our life at various levels.

- The thoughts and feelings which cannot be expressed through words can very often be expressed through art more effectively.

- Beautiful objects (e.g. flower pot), beautiful creations (e.g. drawings and sculpture), beautiful experiences (e.g. films, music, etc.) can be created through the medium of art and this can enrich our life and make it happier.

- A social message can be effectively conveyed through visual art. For example, a sensitive movie or photograph quickly touches the heart of people as compared to a speech.

- Visual art can be effectively used to inspire the masses. Songs based on great work done by great people, poems, films, sculptures, drawing have been inspiring us for ages.



- A study of ancient art works throws light on the life of the people of that time (contemporary life). Antique pieces of art, objects, sculptures, toys, vessels, which are found during excavations, are a witness to those times.

- People come together and respect each other through the medium of art. We develop a sense of respect and love towards other people and their culture when we see or hear about the art belonging to different states and countries.

- A spirit of empathy develops towards them. A relation is established with the people of other states when we see their art, sculpture, cuisine or hear their music.

- Appreciating art subconsciously develops an attitude of finding beauty in life. Art lovers tend to be peace loving, non-violent and adjusting in nature.

- It is said that the best of art is seen in nature. The colours, shapes and sounds in nature have been inspiring humans and one can see a glimpse of that in

human artwork. Connecting with art is like connecting one with nature.

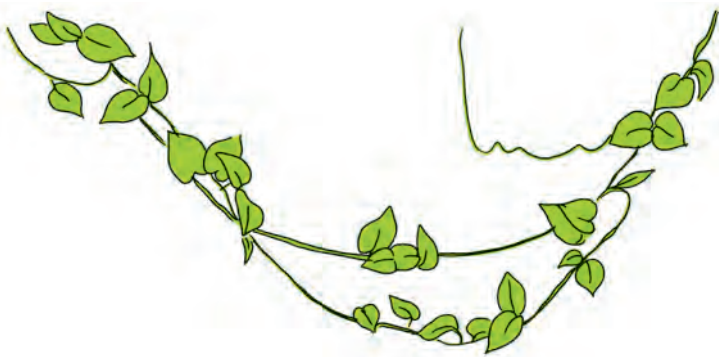

- When we create a piece of art or when we appreciate art, we unknowingly realize our own likes and dislikes. In other words, art develops and enhances our self awareness.

- The importance of art in human life is so much that a life without art is like an animal's / beast's life. For living a complete, enriched human life one must get associated with some form of art.

Try to remember / recollect

Think of songs, sculpture, stories, poems or movies which have inspired you at some time. If so, write about it in your notebook.

Some different types of Visual art

Last year we studied about some commonly known art forms. This year we shall study about some different forms of visual art.

Tribal Art (*Adivasi Kala*)

Like in India, tribal communities are found in other countries and continents too. Most of the tribal art depicts elements of nature. The significant aspect of this art is that in spite of using simple shapes it looks beautiful. Just as the Warli Art of Maharashtra is made using specific shapes, so is the tribal art of Australia.

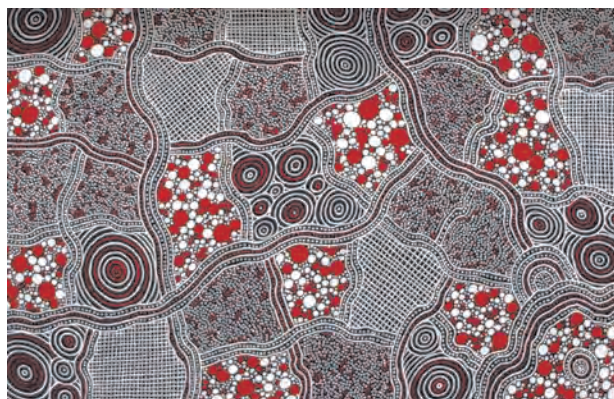
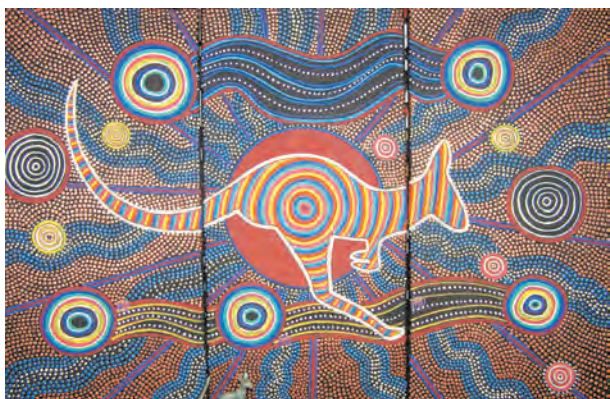

Tribal art of Australia

This art mainly uses dots. The dots can be of varying sizes. These dots may be small or big. Different shapes are made using dots. The dots are drawn with the help of sticks.

Try to find

Is there any tribal or folk art in your vicinity? Try to find it. Talk to the persons creating this art and try to understand their technique.

Kolam Rangoli Art

Kolam Rangoli art is different from the regular Rangoli art form. Many equidistant dots are used and curved or straight lines are drawn around the dots. Designs are made around the dots in continuity. Variety of rangoli patterns can be drawn. In olden times, this Rangoli was made by making a mixture of water and rice flour.

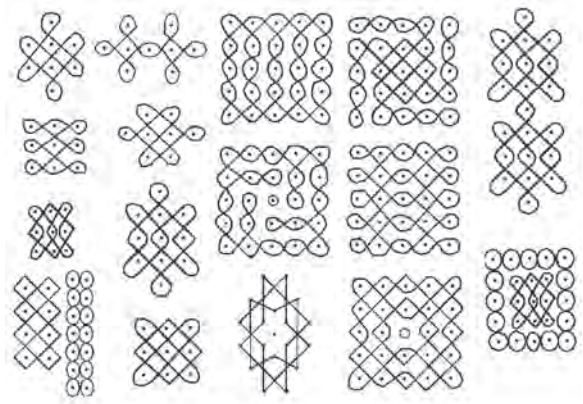

Do this

Divide the students in pairs for a paper and pen activity. In a pair, one student will make a certain pattern of dots and the other will make designs out of them and beautify the pattern making use of all the dots. Then let the second student make dots and the other create a pattern using the dots.



Doodle



Doodle means to use your pen, pencil or sketchpen etc. to draw spontaneous patterns as and how they come to your mind. This can be done in the corner of the pages, on the pictures in the book or on the newspaper. You must have surely drawn such patterns at some point in time. Do you know that it is a great stress buster? Try doing it.

Every doodle is different and unique. Some might draw in their own unique style. Some might copy what they have seen.

Installation

In this art form, the available three dimensional space is used to create a structure. Some artists create permanent installations while some make temporary ones. Andy Goldsworthy is a British installation artist who has created some



excellent installations. Most of his installations are made in a natural setting by using the material available in nature. Sometimes these installations collapse while being created. However he firmly believes in the process of art and feels that even “collapsing is balance”.

Some selected styles of Visual Art

Man draws inspiration for art from nature as well as from his daily life. Thus, the impact of his surroundings, political and social incidents / events is seen on his art. This leads to different thoughts coming forth and various experiments being done. Different ways of expression and new philosophies of art are created. This is what we call styles of art. We shall now get acquainted with some of the styles of visual art.

Let the students carefully observe the pictures of each style and note down the observations. Then tell them about each style.

Impressionism



Monet - 55.3 cm × 64.7 cm
Oil painting on canvas



Van Gogh - 74 cm × 94 cm
Oil painting on canvas



This style came into existence in France in the late 19th century and in the beginning of the 20th century. Earlier to this, the topics of artworks were mainly historical, religious, nature or portraits. But there was no inclusion of the surrounding social conditions. Art used to be confined within the four walls. But when the style of impressionism came into existence in the mid

19th century, objects or topics observed in the surroundings were drawn by artists. The artists stepped out of the four walls and came into the open nature and started sketching and drawing, and so the effect of light on objects was captured. In this style the basic colours are placed one before the other with the help of small dots and lines. When observed from a particular distance the colours seem to merge or blend with each other. The significant aspect of this style is that the high speed moving light of the drawing and the changing conditions of the atmosphere are captured. These pictures depict the contemporary life styles and various shades of light. Some of the famous artists of this style are Monet and Van Gogh.

Cubism



Paul Cezanne
81 cm × 65 cm
Oil painting on canvas



Pablo Picasso
126 cm × 73 cm × 41 cm
Coloured tin sculpture



Pablo Picasso
60 cm × 49 cm
Oil painting on canvas



1907 to 1914 is considered as the flourishing period for Cubism. The chief centre of this style was Paris. Cubism is considered as the most influential style of the 21st century. In this style the object to be drawn is analyzed into various geometrical shapes and these pieces are joined together to form a complete picture. This style emphasises on looking at any object or person through different perspectives and then drawing it.

Shades of light and dark are used to highlight the shapes to transpose the three

dimension objects on to the two dimensional paper. Famous artists of this style were Pablo Picasso and Paul Cezanne.

Surrealism

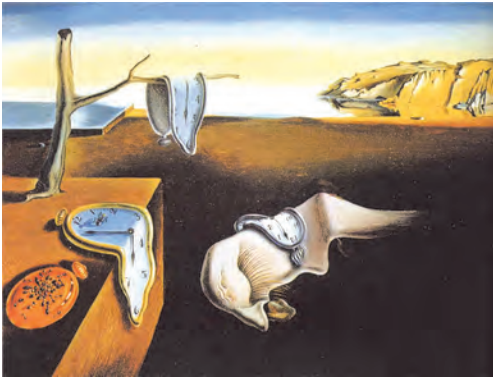

Salvador Dali
24 cm × 33 cm
Oil painting on canvas

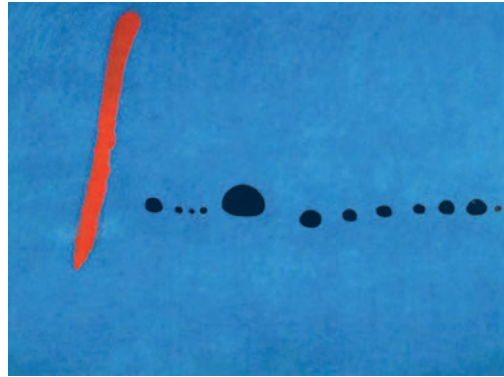

Joan Miro
355 cm × 270 cm
Oil painting on canvas



Joan Miro
A sculpture more than
10 metres in height



This movement began in the beginning of 1920. The objects, persons or incidents that we see in our daily life have an impact on our conscious mind, knowingly or unknowingly. We create an image of these in our mind which is different from its reality. This is the basic philosophy of this style. The surrealist artists are of the opinion that in order to create the image formed on our

inner mind one must keep the mind open. Often symbols are used to represent the real situations and emotions. Salvador Dali and Joan Miro are the famous artists of this movement.

Abstract expressionism



William De Kooning
Oil painting on canvas



Rothko 212 cm × 239 cm
Oil painting on canvas



This style originated in the city of New York in the decade of 1940. This style is similar to surrealism. In a way, it is inspired from surrealism. One can see a liberal use of colours in this style. Two types of artists can be seen using this style. One who paints his art on the canvas using strokes of various bright colours. William De Kooning is very well known for this. The

others like Mark Rothko use one kind of colour and draw simple shape on the canvas, filling the larger parts with colours. Artists of this second type are more religious and philosophical in nature and they expect the viewers to get a meditative and deep experience after looking at the painting.



Let us have some fun

Find the similarities and differences in the styles you have seen and write them in your notebook. Select any one style and try to draw a picture based on it.

Ask the students to look at the art works of each artist first. Let them analyse whether the artist has a particular style. After that ask them to read the information given.

Show the students different works of artists from each style on the internet. Let them find the similarities and differences between each style. Make groups of children according to the style they like. Encourage them to create art work of that style.

Some Indian painters

Just as we got ourselves introduced to some world famous styles and artists, let us now look at some Indian artists.

Jamini Roy (1887 - 1972)

Jamini Roy was one of the first artists to deviate from the western style to draw inspiration from Indian traditional art, folk art and *adivasi* lifestyle and create his own style. While he was trained in the western art style, he was very influenced by the Kalighat art style. Big almond like eyes, round faces, curvy bodies are some distinct features of this style. While he adopted the Kalighat style initially, he later evolved his own style. Renouncing the european pallet, he turned towards natural colours made from mud, seeds, rocks, flowers, indigo etc. You may notice a specific shade of red, yellow, green, grey, blue and white used in his paintings. An attempt



has been made to capture the simplicity in rural lifestyle in his paintings. He always felt that art should be accessible to all and appeal to all. He felt that Indian art should be able create its own identity. He was awarded the Padmabhushan in 1955.

Ramkinkar Baij (1906 - 1980)



Mill call (An indication that the Mill shift begins)



Santhal Family



Dandi Yatra

Baij was a famous sculptor from West Bengal. His art is seen to be inspired from the lifestyle of the *dalit* and *adivasi* communities. Inspired by the local artists, sculptors and observing their work, he made small pieces of artwork since his childhood. In his later life, his sculptures stood out to be distinct and different for their subjects and style. In those days, the subjects of sculptures were mainly deities and political figures. However in 1938, he began deviating from this by creating sculpture of a Santhal (an *adivasi* community) family. In his artwork, he always tried to capture the beauty in the life of communities engaged in manual labour.

Mill call, created in 1956 in Shantiniketan is considered to be a very important sculpture. The sculpture depicts women walking briskly on hearing the mill siren

being followed by a child. The speed of the women walking, the child running has been depicted very beautifully in this sculpture. The movement of the dust flying due to their action has also been captured.

His style consisted of creating sculptures using laterite and cement.

Narayan Shridhar Bendre (1910 - 1992)



Thorn



Make up



Landscape

Narayan Shridhar Bendre was born in Indore. He made a name for himself as a landscape artist. The use of colours in his artwork is considered very special. Since he was fond of travelling around India and the world, his style is seen to be a mixture of Indian and western styles. In his artwork, one can find the influence of impressionist and cubist style. He experimented a lot by combining different styles. He did not approve of sticking to any one style or subject. The subjects of his artworks ranged from everyday incidents to abstract emotions. His artwork mostly bring out peaceful and harmonious emotions. In 1992, he was awarded the Padmabhushan

Deenanath Damodar Dalal (1916 - 1971)

Deenanath Dalal was famous for his cover pages, cartoons, story strips, calenders and picture series published in leading magazines of those times. He was very well received by both - the masses and the critiques. His artwork given alongside will instantly strike a chord with everyone.



B. Prabha (1933 - 2001)



B. Prabha completed her education in art from the J J school of Art, Mumbai. She started working at a time when not many women artists were active in this field. She was highly influenced by Amrita Shergill. Most of Prabha's paintings depict elongated melancholy figures of rural women. Her style of using only one prominent colour in a painting can be seen in most of her paintings. She mostly created oil paintings. Her paintings depict women's social conditions, their hardships, their suffering and their courage in the face of these odds. She often gave voice to women's suppressed feelings. "I haven't seen a single happy woman", she once said. Her paintings were selected for many exhibitions in and outside India.



Let us create

In order to create the art forms mentioned below, you need to remember three rules -

1. Enjoy what you are doing. The goal is not to come up with a beautiful piece of art. The art forms below are called process art. You are going to create something for your own pleasure. You need not show it to anybody.
2. Do not overthink. Go with the flow. Whatever emerges is fine. (There is nothing right / wrong in it.)
3. Do not stop trying under any circumstances. Keep on experimenting.

Try to do

1. Drawing layers of objects

Begin with the floor, a bedsheet on top of it, a book kept on the bedsheet, a tea cup on the book, another book on top of it, a folded piece of cloth over it, a newspaper on top of it, then a bucket over it, a plate on top, a cat sitting on the plate etc. Whether to draw the objects realistically (E.g. If it is a cloth, it will come down from the sides, paper would stay straight) or just as you please is something for you to decide. It is okay even if you feel like creating a collage by sticking together pieces of paper.

In such art pieces it is possible to balance objects which would normally not balance over each other.

2. Drawing with your feet

Hold your pencil or pen between your toes. You can also hold the pen / pencil between the heels of your feet. Try to hold the pencil in your mouth and draw.

3. Creating art from waste

Try to make a face out of any form of waste. You can do this when you have time on your hands or need a break.

4. Creating art using dust

Make a paper wet by sprinkling some water on it. Press it against the dust on the floor or the cobwebs. Try to see some picture that emerges out of it. Try to add to it by using your pen, pencil or colours to create something



new.

5. Creating art using black colour only

Many a times people have some preconceived notions around the colour black. Many people dislike it. However if used appropriately, it can look as good as or may be better than other colours. Use your imagination. Can you create something using only black colour and its shades?

6. Planar Geometry

Discuss about the methods to create different geometric shapes and also about where they can be found with the help of the Mathematics textbook.

Cuboid

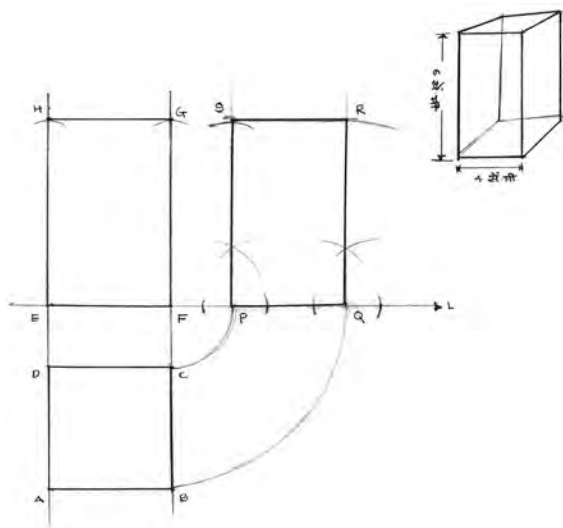

Sphere

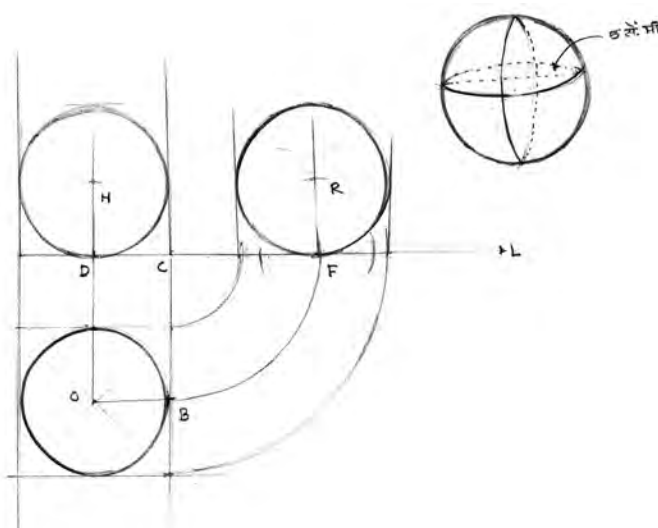

7. Colouring therapy

Therapy refers to a method of healing something. Art can also be used as a therapy. Colouring therapy includes some designs which are pleasing to the eye. These designs are intricate. It is expected to colour the designs as a part of the therapy. As your mind is engrossed in it, you tend to forget the stress. This is the philosophy of this therapy. Look at the design given below. Complete it and colour it.

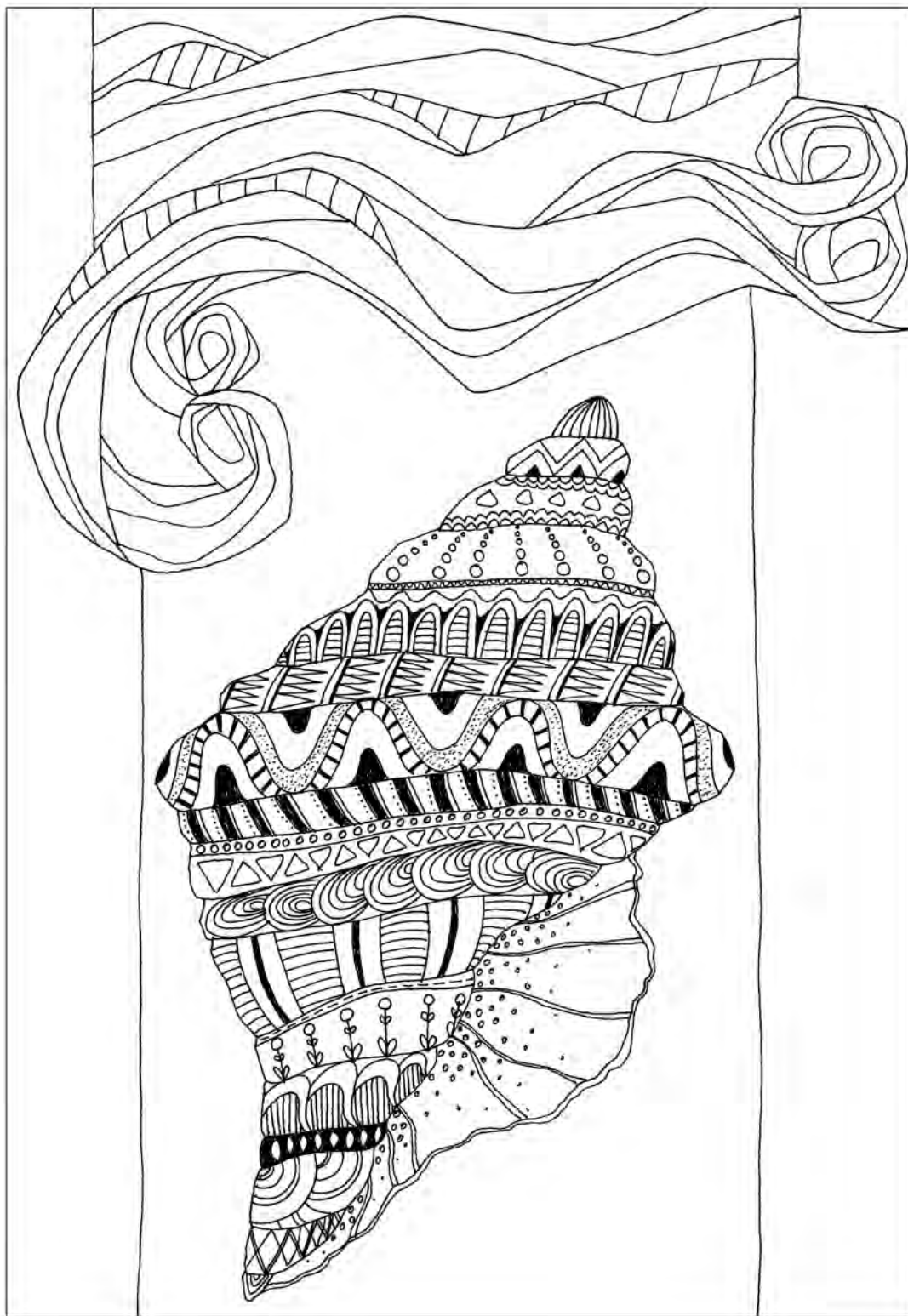

Field Visit



We get to know about the lifestyle, culture and artistic vision of the ancient people by looking at the architecture of that period. Our understanding of art matures through this process. Buddhist caves are situated in the Ajanta mountain range, 60 miles north of Aurangabad. The buddhist caves at Karle are known for their architecture. Arrange a field visit to an ancient architectural building in your area. Note your observations.

What type of art do you like?

Art is a very subjective form of expression. Whatever is beautiful for one person need not be liked by the other. Hence it is not correct to classify art as good or bad. Just because we do not like a particular piece of art, does not mean that it is not beautiful. Avoid labelling any artwork as good or bad. You can just explain why you liked or did not like a particular piece of art.

It is important to articulate why we like or do not like a piece of art. Trying to find what we exactly like or not like in the drawing and trying to express it in words, helps in developing our sense of art. We learn to see different aspects of beauty in the art piece.



Do these things

See different pictures in newspapers, magazines and books. Try to think about what exactly you liked in them and clearly express it in your words. Write in your note book. Try to analyze at least 5 pictures. You may use the given points and may add more.

1. Subject
2. Colour combination
3. Layout
4. Style
5. Imagination
6. Use of light and shadow etc.



Career in the field of Art

A career in visual art can begin either after 10th or 12th standard.

After 10th, one can get admission to Foundation or G. D. Arts courses. Many prefer to do Art Teacher's diploma after the Foundation course. G. D. Arts is a four years course after which one can study Applied Arts or Fine Arts. Diploma can also be done after 12th standard.

In recent times, courses like sculpting, fashion designing, architecture, jewellery designing, animation, interior decoration, photography etc. are also easily available.

More information can be seen on the given site - www.mahacareermitra.in

Some thoughts about Art

Words fall short to explain the importance of art in human life. There are many opinions, views and thoughts about art. How would you interpret the following statements about art?

- The aim of art is to clear the dust fallen on our minds in our daily life.
- A painting is like a poem without words.
- Life is a canvas and you are the artist.
- Art enables us to find ourselves and lose ourselves at the same time.
- Every child is an artist. The problem is how to remain an artist once we grow up.

Assessment (Weightage 20%)

Criteria	Great	Fine	Incomplete	Marks
	Very Good	Satisfactory	Not satisfactory	
Creativity in the artwork	Completed all the activities creatively and actively.	Just completed the activities as a task.	Participated in only some activities.	
Writing about the artworks.	Analyzed the five art pieces clearly on the basis of the six points given.	Analyzed the five art pieces vaguely. Not all the six points were used.	Incomplete work	

